

DELHI METRO RAIL CORPORATION LTD.

"Contract D2C-06: Design and Construction of Twin Tunnel by Shield TBM, ~~Cut & Cover tunnel box, Underground ramp and~~ & by method other than TBM, four underground stations namely, Dayabasti, Sarai Rohilla, Ajmal Khan park, Jhandewalan Mandir and Balance work of works for Nabi Karim Station with Entry/Exits including Retrieval/Launching shafts, Architectural Finishing, Water Supply, Sanitary Installation & Drainage works from chainage (down line) CH: ~~440.000 mt~~ 614.483 mt. to CH: 7629.531 mt of Inderlok-Indraprastha corridor (~~Extn. of Line-5~~) of Delhi MRTS Project of Phase-IV."

**Addendum-8
Summary Sheet**

S. No.	Part/ Section	Document Name	Page No.	Clause No./ Item no.	Addendum/Corrigendum	Remarks
1		Invitation for Bids	2	6, 7 & 8	Change in deadline of Bid submission, date of opening of Technical Bids etc	Replace page 2R5 by 2R6
2	Part-1, Section II	Bid Data Sheet	4 & 7	ITB 19.2, 22.1 & 25.1	Change in deadline of submission of Bid Security in "Original", deadline of Bid submission & date of opening of Technical Bids.	Replace pages 4R5 & 7R5 by 4R6 & 7R6 respectively
3	Part-1, Section IV	Bidding Forms	8	Annexure to Schedule A: A2	Schedule of on Account Payment {Annexure to Schedule A: A2, Construction of Underground stations(Daya Basti,Sarai Rohilla, Ajmal Khan park & Jhandewalan, balance work of Nabi Karim)} has been modified (Note-3 has been added)	Replace page 8R by 8R1
4	Part-2	Part-B: Technical Specifications			IS 1893:2025 (Latest Code)	Copy of the circulation code (IS 1893- Part-1(2025) is appended(116 pages) to the technical specification
5	Part-2	Part-B: Technical Specifications	10 pages		List of Approved Manufacturers for Architectural Finishing Materials (October 2024) (Page 1 to 10) replaced with List of Empanelled Manufacturers/ Suppliers of Major Architecture Items (as on 14.11.2025) (Page 1 of 10)	Complete list is revised. For updates regarding validity dates, please refer DMRC website.
6	Reply to Pre-bid queries (02 pages)					

payable at New Delhi from a Scheduled Commercial Bank based in India or RTGS/ NEFT/ IMPS in the bank account of Delhi Metro Rail Corporation Limited as mentioned below.

DMRC Ltd. Tender Cell Account No. 000705045337

ICICI Bank, 9A, Phelps Building, Connaught Place, New Delhi-110001

Account Type: Current, IFSC code: ICIC0000007

In case, the payment of cost of the Bidding Documents is in the form of Demand Draft / Pay Order / Bank Draft, it shall reach the office of Sr. General Manager/Contract at the address mentioned below before the deadline for Bid submission as per BDS 22.1.

Office of Sr. General Manager/Contracts
Delhi Metro Rail Corporation Limited
5th floor, A-Wing, Metro Bhawan
Fire Brigade Lane, Barakhamba Road
New Delhi - 110 001, India

6. Bids must be submitted online on the e-tendering website <https://eprocure.gov.in/eprocure/app> from ~~01.07.2025~~ ~~22.07.2025~~ ~~01.08.2025~~ ~~29.08.2025~~ ~~22.09.2025~~ ~~13.10.2025~~ 11.11.2025 (0900 hrs) to ~~08.07.2025~~ ~~29.07.2025~~ ~~08.08.2025~~ ~~08.09.2025~~ ~~29.09.2025~~ ~~21.10.2025~~ ~~18.11.2025~~ 24.11.2025 (1500 hrs) and must be accompanied by a Bid Security of ~~INR 240~~ **236** Million.
7. Bids will be opened on the e-tendering website <https://eprocure.gov.in/eprocure/app> at **1500 hrs** on ~~09.07.2025~~ ~~30.07.2025~~ ~~11.08.2025~~ ~~09.09.2025~~ ~~30.09.2025~~ ~~22.10.2025~~ ~~19.11.2025~~ 25.11.2025.
8. Key Details for Contract D2C-06 are as follows:
 - Completion period of the Work: **Forty Two (42) months**
 - Sale of Bidding documents: From ~~20.05.2025~~ to ~~08.07.2025~~ ~~29.07.2025~~ ~~08.08.2025~~ ~~08.09.2025~~ ~~29.09.2025~~ ~~21.10.2025~~ ~~18.11.2025~~ 24.11.2025.
 - Pre-bid Meeting **1100 hrs** on ~~06.06.2025~~ as per BDS 7.4
 - Deadline for Bid submission: **1500 hrs** on ~~08.07.2025~~ ~~29.07.2025~~ ~~08.08.2025~~ ~~08.09.2025~~ ~~29.09.2025~~ ~~21.10.2025~~ ~~18.11.2025~~ 24.11.2025 as per BDS 22.1
 - Technical Bid Opening date: **1500 hrs** on ~~09.07.2025~~ ~~30.07.2025~~ ~~11.08.2025~~ ~~09.09.2025~~ ~~30.09.2025~~ ~~22.10.2025~~ ~~19.11.2025~~ 25.11.2025 as per BDS 25.1

Notes for Bidders:

1. The intending Bidders must be registered on e-tendering portal <https://eprocure.gov.in/eprocure/app>. Those who are not registered on the e-tendering portal shall be required to get registered beforehand. After registration, the bidder will get user id and password. On login, bidder can participate in bidding process and can witness various activities of the process.
2. The authorized signatory of intending bidder, as per Power of Attorney, must have valid Class-III digital signature. The Bidding Documents can only be downloaded or uploaded using Class-III digital signature. However, the bidder shall upload their bid on <https://eprocure.gov.in/eprocure/app> using Class-III digital signature of the authorized signatory only.
3. Bid submissions shall be done online on <https://eprocure.gov.in/eprocure/app> after uploading the scanned documents towards cost of Bidding Documents (scanned copy of Demand Draft / Pay Order / Bank Draft or of transaction of payment in case of RTGS/ NEFT/ IMPS), scanned copy of Bid Security and other documents as stated in the Bidding Documents. Instructions for on-line bid submission are furnished hereinafter.
4. Submission of bids shall be closed on e-tendering website at the date and time of submission prescribed in IFB (or extended deadline, if any, as per ITB 22.2) after which no bid shall

ITB 16.2(b)	Supply of Mandatory Spare Parts or Recommended Spare Parts is not required for this Contract. Hence Not Applicable.
ITB 16.3	"At this time the Employer does not intend to execute certain specific parts of the Works by subcontractors (i.e.: nominated Subcontractors) selected in advance."
ITB 18.1	The Bid validity period shall be 120 days after the latest bid submission deadline date prescribed in ITB 22.1.
ITB 18.3 (a)	Not applicable.
ITB 19.1	The amount and currency of the Bid Security shall be INR 240 236 Million.
ITB 19.2	<p>For submission of Bid Security in "Original", the Employer's address is:</p> <p>Office of Sr. General Manager/Contracts Delhi Metro Rail Corporation Limited 5th floor, A-Wing, Metro Bhawan Fire Brigade Lane, Barakhamba Road New Delhi - 110 001 India</p> <p>The deadline for submission of Bid Security in "Original" is:Date: 08.07.2025 29.07.2025 08.08.2025 08.09.2025 29.09.2025 21.10.2025 <u>18.11.2025 24.11.2025.</u></p> <p>Time: 1500 hrs</p>

D. Submission and Opening of Bids	
ITB 21.1	Bidders shall submit their Technical Bid and Price Bid on e-tendering website https://eprocure.gov.in/eprocure/app .
ITB 21.2	Not Applicable.
ITB 21.3	Not Applicable.
ITB 21.4	Not Applicable.
ITB 21.5	Not Applicable.
ITB 21.6	Not Applicable.
ITB 22.1	Bidders shall submit their Technical Bid and Price Bid on e-tendering website https://eprocure.gov.in/eprocure/app . The deadline for Bid submission is: Date: 08.07.2025 29.07.2025 08.08.2025 08.09.2025 29.09.2025 21.10.2025 18.11.2025 <u>24.11.2025</u> . Time: 1500 hrs
ITB 24.1	Not Applicable.
ITB 24.2	Not Applicable.
ITB 24.3	Not Applicable.
ITB 25.1	The Technical Bid shall be opened on e-tendering website https://eprocure.gov.in/eprocure/app The date and time for Opening of Technical Bids is: Date: 09.07.2025 30.07.2025 11.08.2025 09.09.2025 30.09.2025 22.10.2025 19.11.2025 <u>25.11.2025</u> . Time: 1500 hrs
ITB 25.2	Not Applicable.
ITB 25.3	Not Applicable.
ITB 25.4	Not Applicable.
ITB 25.5	Not Applicable.
ITB 25.7	At the end of the evaluation of Technical Bids, the Employer will notify the Bidders, on tendering website https://eprocure.gov.in/eprocure/app , who have submitted substantially responsive Technical Bids and who have been determined as being qualified for award. The date and time of the opening of Price Bids will also be notified through e-tendering website https://eprocure.gov.in/eprocure/app . The opening of the Price Bids will also be on e-tendering website https://eprocure.gov.in/eprocure/app .

"Contract D2C-06: Design and Construction of Twin Tunnel by Shield TBM, Cut & Cover tunnel box, Underground ramp and & by method other than TBM, four underground stations namely, Dayabasti, Sarai Rohilla, Ajmal Khan park, Jhandewalan Mandir and Balance work of works for Nabi Karim Station with Entry/Exits including Retrieval/Launching shafts, Architectural Finishing, Water Supply, Sanitary Installation & Drainage works from chainage (down line) CH: 440.000 mt 614.483 mt. to CH: 7629.531 mt of Inderlok-Indraprastha corridor (Extn. of Line-5) of Delhi MRTS Project of Phase-IV."

Sub : A2, Construction of Underground Stations (Daya Basti, Sarai Rohilla, Ajmal Khan park & Jhandewalan, balance work of Nabi Karim)

Annexure to schedule 'A'

Schedule of on Account Payment

Item no.	Item of Payment	Percentage payable of A2
	All works as detailed in the Tender drawings and/or specified in the Employer's Requirement.	
	Dayabasti Station = 20% of A2 Sarai rohilla Station = 22.5% of A2 Ajmal khan park Station = 22.5% of A2 Jhandewalan Mandir Station = 27.5% of A2 Nabi Karim station = 7.5% of A2	
1	Construction of Sheet Pile/Soldier Pile/diaphragm wall/side wall completed (Based on proportional Progress)	15.00%
2	Excavation in all kinds of soil/rock including strut / waler supports / rock Bolt/rock Anchor including dewatering etc. As required (measurement to be done in volume of earthwork excavated)	10.50%
3	Construction of base slab (Based on proportional progress) including Earth Mats	16.00%
4	Construction of walls , beams & columns , other RCC works like platform slab , under platform walls, columns , staircases , lift walls & escalator pits works upto concourse level (The mode of measurement will be as decided by the Engineer at site).	5.00%
5	Construction of Concourse & Indermediate slab (Based on proportional progress)	12.50%
6	Construction of first stage concrete if required, cast in situ/precast OTE ducts above track complete (Based on proportional progress) & laying screed on base slab in undercroft as per design	5.00%
7	Construction of walls , beams & columns , other RCC works like platform slab , under platform walls, columns , staircases , lift walls & escalator pits works upto Intermediate and roof level (The mode of measurement will be as decided by the Engineer at site).	7.50%
8	Construction of all roof slab including RCC work above roof slab including water proofing if any (Based on proportional progress)	12.50%
9	Construction of Entry/Exit structures including subways and interconnection with existing metro stations as required. (Based on proportional progress)	7.50%
10	Construction of complete Ancillary Building including interconnection with station.	6.00%
11	All other balance work as per as per the employer requirements as detailed in tender drawings & specifications, handing over of stations & submission of as built drawings to the Employer complete in all respect.	2.50%
	Total	100.00%

Note 1: The Contractor may submit distribution of each of the above percentage with sufficient justification. The Contractor may be paid in accordance with these distributed percentage points after approval of the Engineer.

Note 2: The Contractor shall propose further break up based on each activity for each station as per the approval of the Engineer.

Note 3: Schedule of on Account payments for sub head A2 given from Item No.1 to 11 (i.e. construction of underground Station Dayabasti, Saral Rohilla, Ajmal Khan park, Jhandewalan Mandir & Balance work of Nabi Karim station shall be for four stations i.e Dayabasti, Saral Rohilla, Ajmal Khan park & Jhandewalan Mandir. For the Balance work of Nabi Karim station the payment breakup shall be followed in line with clause no. 2.1.1 of Employers Requirement, Functional. Further, schedule of on Account payment for balance work of Nabi Karim station (i.e. 7.5% of A2) will be followed as per the approval of Engineer at the time of execution of work.

भारतीय मानक
Indian Standard

IS 1893 (Part 1) : 2025

डिज़ाइन भूकंपीय जोखिम और संरचनाओं
के भूकम्परोधी डिज़ाइन के मानदंड —
रीति संहिता

भाग 1 सामान्य प्रावधान
(सातवां पुनरीक्षण)

**Design Earthquake Hazard
and Criteria for Earthquake-Resistant
Design of Structures — Code of Practice
Part 1 General Provisions
(Seventh Revision)**

ICS 91.120.25

© BIS 2025



भारतीय मानक ब्यूरो
BUREAU OF INDIAN STANDARDS
मानक भवन, 9 बहादुर शाह ज़फ़र मार्ग, नई दिल्ली 110002
MANAK BHAVAN, 9 BAHADUR SHAH ZAFAR MARG
NEW DELHI 110002
www.bis.gov.in www.standardsbis.in

June 2025

Price Group X

FOREWORD

This Indian Standard (Part 1) (Seventh Revision) was adopted by the Bureau of Indian Standards, after the draft finalized by the Earthquake Engineering Sectional Committee had been approved by the Civil Engineering Division Council.

About 61 percent of India's land area (with over 75 percent of its population living in it) is prone to moderate to strong earthquake shaking intensities (*see* Annex B for 1964 MSK intensity scale for earthquake ground shaking). Hence, earthquake-resistant design and construction is essential. This standard provides a revised earthquake zone map considering the known faults, the maximum size of events likely on these faults, the attenuation of the ground shaking with distance, tectonics and lithology (*see* Annex C) across the country. The earthquake zone map provided in this standard reflects the relative peak ground accelerations likely across the landmass of India. These peak ground accelerations can be statistically correlated to the intensity of earthquake ground shaking measured on the 1964 MSK scale.

Safety of people in a structure during earthquakes depends on two factors, namely:

- a) *Structural Elements* — How the structural elements (*SEs*) of a building or structure individually and together resist the design earthquake shaking, without local or global collapse of the building or structure; and
- b) *Architectural Elements and Utilities* — How the non-structural elements, hereinafter called as the architectural elements and utilities (*AEUs*), namely contents, appendages, and services and utilities, of a building or structure, are held by or rested on *SEs*, such that they do not jeopardize the safety of persons in the building and/or structure.

So far, significant attention was given to the former. Safety of the people can be jeopardized, even if the *SEs* perform as expected, but *AEUs* fail to withstand earthquake shaking. In countries that managed to reduce loss of life by preventing collapse of buildings and structures, losses in recent earthquakes indicate that losses of life and damage to property are not eliminated yet owing to poor performance of *AEUs*. These losses of life and damage to property have major social or economic implications, particularly in critical buildings and structures (for example, governance buildings, hospitals, and schools) and commercial buildings and structures (for example, malls, convention centres, and milk and food supply stores).

This standard provides the requirements for the:

- a) *Design of SEs* — The minimum design earthquake lateral forces to be considered in the design of *SEs*. The structures designed by these provisions are expected to sustain damage when subjected to design ground shaking specified in this standard, but not collapse; and
- b) *Protection of AEUs* — The minimum design earthquake lateral forces and design earthquake lateral displacements to be considered in the design of the connection of the *AEUs* with the *SEs*. The connections of *AEUs* designed by these provisions are expected to perform better than those merely provided without following these provisions, when the structure is subjected to design ground shaking specified in this standard.

These are minimum provisions that should be complied with to ensure the safety of the *SEs* and *AEUs*. The owner of the structure may choose to reduce the damage in the *SEs* and *AEUs* under design earthquake ground shaking effects, by prescribing design lateral forces and displacements that are higher than those specified in this standard.

This standard was first published in 1962 with the title 'Recommendations for earthquake-resistant design of structures', and revised in 1966, 1970, 1975 and 1984. In the fifth revision, IS 1893 was decided to be published in parts. Part 1 'General provisions and buildings' was then published in the year 2002 and revised again in 2016, when some significant changes were made. The other parts of IS 1893 which were published are:

- Part 2 Liquid-retaining structures
- Part 3 Bridges and retaining walls
- Part 4 Industrial structures
- Part 6 Base-isolated buildings

In this revision, the Committee decided to present the provisions for different types of structures in separate parts, to keep abreast with rapid developments and extensive research carried out in earthquake-resistant design of different types of structures. The other parts of this series are:

- Part 2 Liquid-retaining structures
- Part 3 Bridges
- Part 4 Industrial structures
- Part 5 Buildings
- Part 6 Base-isolated buildings
- Part 7 Long-distance pipelines (*under preparation*)
- Part 8 Dams (*under preparation*)
- Part 9 Steel towers (*under preparation*)
- Part 10 Coastal structures (*under preparation*)
- Part 11 Tunnels (*under preparation*)
- Part 12 Earth-retaining structures (*under preparation*)

This standard contains provisions on design earthquake hazard and criteria for earthquake-resistant design applicable to all structures. Unless stated otherwise, the provisions in Part 2 to Part 12 of IS 1893 shall be read necessarily in conjunction with the general provisions as laid down in this standard. Alongside IS 1893 (Part 1) to (Part 12), parallel series of standards are under formulation on:

- a) Earthquake-resistant design and detailing of structures as IS 13920 (Part 1) to (Part 12); and
- b) Assessment and retrofit of structures for earthquake safety as IS 13935 (Part 1) to (Part 12).

In this revision, the following major changes have been incorporated:

- a) The title of the standard is modified to ‘Design earthquake hazard and criteria for earthquake resistant design of structures: Part 1 General provisions’;
- b) A revised earthquake zone map is introduced, which is based on probabilistic earthquake hazard assessment;
- c) The design acceleration response spectra are defined up to natural period of 10 s;
- d) The design horizontal acceleration coefficients are specified for each earthquake zone corresponding to different return periods, for use in design;
- e) The response history method is strengthened by providing suites of ground motions for each of earthquake Zones II, III, IV, V and VI, whose response spectra envelope to be the target design response spectrum. Also, both near-fault and far-fault ground motions are provided for earthquake Zones V and VI;
- f) A method is provided to account for soil flexibility in analysis and design;
- g) The method to estimate liquefaction potential at a site is revised; and
- h) The clause on protection of architectural elements and utilities in structures is introduced.

A probabilistic earthquake hazard map (PEHM) was prepared by the National Disaster Management Authority (NDMA) in 2010. The PEHM introduced in this standard is based on additional research undertaken at Indian Institute of Technology Madras with financial assistance from the Department of Science & Technology. Further, through another financial support from NDMA, IIT Madras has conducted another study to further refine the PEHM in 2023. BIS acknowledges the above efforts. A brief note on the development of PEHM used in this standard is included in Annex C for information.

In the formulation of this standard, effort has been made to coordinate with standards and practices prevailing in different countries in addition to relating it to the practices in the field in this country. Assistance has particularly been derived from the following publications:

ASCE/SEI 7-22, (2022), 'Minimum design loads for buildings and other structures', American Society of Civil Engineers, USA

FEMA 577, (2007), 'Design guide for improving hospital safety in earthquakes, floods and high winds', Washington, DC, USA

FEMA E74, (2012), 'Reducing the risks of non-structural earthquake damage — A practical guide', ATC, CA, USA, USA

FEMA, (2020), 'Recommended seismic provisions for new buildings and other structures, Volume I: Part 1 Provisions, Part 2 Commentary, FEMA P-2082-1', Federal Emergency Management Agency, Washington DC, USA, September 2020

IBC, (2021), 'International Building Code', International Code Council, USA

JICA, (1994), 'Specifications for highway bridges', Part IV, Japan International Cooperation Agency

NDMA, (2011), 'Development of Probabilistic Seismic Hazard Map of India', Technical Report, National Disaster Management Authority, Government of India, New Delhi, March 2011

NDMA, (2016), 'National disaster management guidelines: Hospital safety', National Disaster Management Authority, Government of India, New Delhi

NDMA, (2023), 'Probabilistic Seismic Hazard Map of India', Technical Report, National Disaster Management Authority, Government of India, New Delhi, March 2023

NZS, (2016), Structural design actions, Part 5: Earthquake actions – New Zealand, NZS 1170.5 : 2016, Standards New Zealand, Wellington, New Zealand

This standard contributes to the following sustainable development goals, Goal 9: 'Industry, innovation and infrastructure' towards building resilient infrastructure, promote inclusive and sustainable industrialization and fostering innovation, and Goal 11: 'Sustainable cities and communities' towards making cities (including human settlements), safe, resilient, and sustainable.

Also, considerable assistance has been given by Indian Institute of Technology Madras, Indian Institute of Technology Bombay, Geological Survey of India, India Meteorological Department, National Center for Seismology, Institute for Seismological Research, CSIR National Geophysical Research Institute, CSIR Central Building Research Institute, National Thermal Power Corporation, VMS Consulting Engineers Private Limited, R. S. Mandrekar and Associates, PVS Structech, PCR Structural Consultants, K and G Consultants, and several other organisations.

The composition of the Committee responsible for the revision of this standard is given in Annex F.

For the purpose of deciding whether a particular requirement of this standard is complied with, the final value observed or calculated, expressing the result of a test or analysis, shall be rounded off in accordance with IS 2 : 2022 'Rules for rounding off numerical values (*second revision*)'. The number of significant places retained in the rounded off value should be the same as that of the specified value in this standard.

CONTENTS

SI No.	Index	Pages
1	SCOPE	
2	REFERENCES	
3	TERMINOLOGY	
4	SYMBOLS AND ABBREVIATIONS	
5	GENERAL PRINCIPLES	
5.1	Site Selection	
5.1.1	Liquefaction	
5.1.2	Landslides	
5.2	Ground Motions	
5.2.1	Far-Fault Effects	
5.2.2	Near-Fault Effects	
5.2.3	Spatial Variation	
5.2.4	Vertical Ground Motions	
5.3	Earthquake Effects on Structures	
5.3.1	Design Forces	
5.3.2	Inelastic Behaviour	
5.3.3	Floor Response Spectrum	
5.4	Soil Structure Interaction	
5.5	Classification of Structures	
5.5.1	Categories of Structures	
5.5.2	Types of Structures	
5.6	Performance Expectation	
5.6.1	Damage	
5.6.2	Integrity	
6	DESIGN EARTHQUAKE HAZARD	
6.1	Earthquake Ground Shaking	
6.1.1	Horizontal and Vertical Shaking Effects	
6.2	Design Earthquake Hazard	
6.2.1	Earthquake Zones	
6.2.2	Design Earthquake Peak Ground Acceleration	
6.2.3	Elastic Pseudo-Acceleration, Pseudo-Velocity and Displacement Response Spectra	
6.3	Site-Specific Earthquake Hazard	
6.3.1	Mandatory Requirement for Site-Specific Earthquake Hazard Assessment	
6.3.2	Lower Bound of Site-Specific Spectrum	
6.3.3	Procedure for Site-Specific Earthquake Hazard Assessment	
7	CRITERIA FOR EARTHQUAKE-RESISTANT DESIGN OF STRUCTURES	
7.1	Structural Configuration	
7.2	Initial Lateral Stiffness	

7.3	Lateral Strength	
7.4	Ductility	
7.5	Relative Displacement Capability	
7.6	Deformability	
7.7	Collapse Mechanism	
7.8	Energy Dissipation Mechanism	
8	EARTHQUAKE DEMAND	
8.1	Assumptions	
8.2	Design Earthquake Forces	
8.2.1	Seismic Weight	
8.2.2	Importance Factor	
8.2.3	Elastic Force Reduction Factor	
8.2.4	Design Earthquake Forces	
8.3	Earthquake Analysis	
8.3.1	Analytical Model	
8.3.2	Modal Analysis	
8.3.3	Methods of Earthquake Analysis	
8.4	Load Combinations	
8.4.1	Basic Load Combinations	
8.4.2	Additional Load Combinations	
8.4.3	Multi-Directional Earthquake Shaking	
8.5	Design Demand	
8.5.1	Designing for Effects from Earthquake Load Combinations	
8.5.2	Designing for Effects from Non-Earthquake Load Combinations	
9	GEOTECHNICAL ASPECTS	
9.1	Soil Properties	
9.1.1	Basic Input	
9.1.2	Soil Flexibility	
9.1.3	Soil Strength	
9.1.4	Soil Damping	
9.2	Liquefaction	
9.2.1	Estimation of Cyclic Stress Ratio	
9.2.2	Estimation of Cyclic Resistance Ratio	
9.2.3	Assessing Liquefaction Potential of a Site	
10	ARCHITECTURAL ELEMENTS AND UTILITIES	
10.1	Classification of AEUs	
10.2	Protection of AEUs	
10.3	Load Effects for Design of System to Protect AEUs	
10.3.1	Acceleration-Sensitive <i>A-AEUs</i>	
10.3.2	Displacement-Sensitive <i>D-AEUs</i>	
10.3.3	Acceleration-cum-Displacement-Sensitive <i>AD-AEUs</i>	
10.4	Earthquake Analysis	

10.5	Earthquake Demands on <i>AEUs</i>	
10.5.1	Acceleration-Sensitive <i>AEUs</i>	
10.5.2	Displacement-Sensitive <i>AEUs</i>	
	ANNEXES	
ANNEX A	LIST OF REFERRED STANDARDS	
ANNEX B	MSK 1964 INTENSITY SCALE	
ANNEX C	EARTHQUAKE HAZARD ASSESSMENT FOR MACRO-ZONING AND SITE-SPECIFIC STUDIES	
ANNEX D	EARTHQUAKE ZONES OF SELECT TOWNS AS PER 2011 CENSUS OF INDIA	
ANNEX E	GROUND MOTIONS FOR LINEAR AND NONLINEAR DYNAMIC ANALYSES OF STRUCTURES	
ANNEX F	COMMITTEE COMPOSITION	

Indian Standard

DESIGN EARTHQUAKE HAZARD AND CRITERIA FOR EARTHQUAKE-RESISTANT DESIGN OF STRUCTURES

PART 1 GENERAL PROVISION

(*Seventh Revision*)

1 SCOPE

1.1 This standard (Part 1) primarily specifies the minimum design earthquake hazard and criteria to be considered in the earthquake-resistant design of structures. Additionally, it outlines the principles of earthquake-resistant design, desirable and unacceptable features of earthquake-resistant structural system configurations, and methods of analysis and treatment of geotechnical aspects for all types of structures. Additional requirements pertaining to different types of structures are dealt separately within IS 1893 (Part 2) to (Part 12).

1.2 Structures, like multi-level parking structures, security cabins (which guard important, critical and special structures), and ancillary structures (like water and sewage treatment plants, and electrical sub-stations) associated with important, critical and special structures need to be designed for appropriate earthquake effects as per this standard.

1.3 Temporary structures and elements, such as scaffolding and temporary shoring for excavations, need to be designed as per this standard, if they are in use for more than a month.

1.4 The provisions of this standard are applicable even to critical and special structures, like petroleum refinery plants. In the design of such structures, additional requirements may be imposed by the associated statutory authorities in India. Some of them may be permitted to estimate design earthquake hazard by site-specific assessment, as required by IS 1893 (Part 2) to (Part 12) depending on the structure type.

1.5 This standard provides requirements for at least the minimum forces and displacements to be considered in the design and construction of the connections of the architectural elements and utilities (AEUs) to the buildings and structures in which they are housed, to resist the effects of design earthquake ground shaking.

1.5.1 The provisions of this standard shall be applicable for the planning, design, and construction of AEUs in new buildings and structures.

1.5.2 The provisions of this standard shall be complied with in the protection of AEUs in critical structures and special structures, while in all other structures, the provisions may be used for the protection of AEUs.

1.5.3 The provisions of this standard related to the protection and design of AEUs shall not be applicable, if any of the following conditions are met with:

- a) The mass of a single AEU is more than 1 percent of that of the whole structure on which it rests;
- b) The total mass of all AEUs at a certain level together is more than 10 percent of that of the whole structure on which they rest; and
- c) The mass of a single AEU is more than 1 percent, but total mass of all AEUs at a certain level together is less than 10 percent of that of the whole structure and the ratio of the natural period of the AEU and that of the whole building is in the range 0.80 to 1.25.

When any of the above conditions is met, the AEU or the said AEUs shall be included in the analytical model of the structure, which is used in the analysis of the structure. Additional criteria for AEUs placed in different structures are provided in the respective part of IS 1893 depending on the structure type.

1.6 The provisions of this standard are not applicable to radiation-related facilities of nuclear power plants, for which the requirements specified by the competent authority to regulate such structures shall be applicable.

1.7 Some of these structural systems have been restricted in higher earthquake zones, as specified in the IS 1893 (Part 2) to (Part 12) depending on the structure type. The elastic force reduction factor R of the structural systems provided in the respective parts of IS 1893 are a measure of the relative ductility in these structural systems.

2 REFERENCES

The standards listed in Annex A contain provisions, which, through reference in this text, constitute provisions of this standard. At the time of publication, the editions indicated were valid. All standards are subject to revision, and parties to agreements based on this standard are encouraged to investigate the possibility of applying the most recent edition of these standards.

3 TERMINOLOGY

For this standard, definitions given below shall apply to all structures, in general. For definitions of terms pertaining to soil mechanics and soil dynamics, reference may be made to IS 2809 and IS 2810, and for definition of terms pertaining to 'loads', reference may be made to IS 875 (Part 1) to (Part 5).

3.1 Architectural Elements and Utilities (AEUs)

— The contents (including imposed loads, other than human beings and animals), the appendages, and/or the services and utilities of buildings or structures.

3.1.1 Rocking — An *AEU* which oscillates back and forth laterally on its supports resting on a horizontal or inclined surface of the structure (floor or roof), without sliding or toppling during earthquake shaking.

3.1.2 Sliding — An *AEU* which moves laterally on horizontal or inclined surfaces of the structure (floor or roof), without rocking or toppling during earthquake shaking.

3.1.3 Toppling — An *AEU* which falls off sideward on horizontal or inclined surfaces of the structure (floor or roof), without rocking or sliding during earthquake shaking.

3.2 Bare Structure — Building or structure without *AEUs*.

3.3 Base Shear Force — The horizontal shear force at the base of the structure.

3.3.1 Design Base Shear — The horizontal shear force induced at the base of the structure under the action of the design earthquake ground shaking specified in this standard.

3.3.2 Overstrength Base Shear — The horizontal shear force induced at the base of the structure when it sustains desirable ductile inelastic actions under the action of the earthquake ground shaking specified in this standard.

3.4 Closely-Spaced Modes — The natural modes of oscillation of a structure, whose natural periods differ from each other by 10 percent or less of the larger natural period.

3.5 Damping — The effect of interface friction owing to slipping, sliding, etc, which helps in reducing the amplitude of oscillation, and expressed as a fraction of critical damping.

3.5.1 Critical Damping — The minimum value of damping that prevents oscillations in the structure.

3.5.2 Damping Ratio — The ratio of the damping present in the structure and the critical damping.

3.6 Design — The proportioning of the members of the structure such that under the action of the designated design level load combinations, the stresses or strains in these members are less than the corresponding specified design values.

3.7 Design Acceleration — The acceleration used to estimate the effects of design earthquake shaking on the building or *AEU*.

3.8 Design Acceleration Spectrum — An average smoothed graph of maximum acceleration of the mass of a single degree of freedom system as a function of natural period of oscillation corresponding to a specified damping ratio under the expected earthquake excitations.

3.9 Design Horizontal Acceleration Coefficient

$[A_H(T)]$ — The horizontal acceleration divided by peak ground acceleration, which is used to estimate the effects of design earthquake shaking imposed at the base of the structure.

3.10 Design Horizontal Force — The horizontal earthquake force that shall be used to estimate the effects of design earthquake shaking imposed at the base of the structure.

3.11 Ductility — The capacity of a structure (or its members) to undergo inelastic deformations without significant loss of strength.

3.12 Earthquake Zone Factor (Z) — The value of peak ground acceleration divided by acceleration due to gravity to be considered towards the estimation of the effects of design earthquake shaking on the structure, corresponding to the return period and the earthquake zone in which the structure is located.

3.13 Elastic Force Reduction Factor (R) — The factor by which the base shear induced in a

structure if it were to remain elastic, is reduced to obtain the design base shear, which depends on:

- a) the earthquake performance of the structure, which is characterized by ductile or brittle deformations;
- b) the partial safety factors for loads and materials; and
- c) the redundancy in the structure or overstrength inherent in the design process.

3.14 Engineering Bedrock — The layer of the earth's stratum below which the shear wave velocity is 760 m/s or more.

3.15 Epicentre — The geographical point on the surface of the earth vertically above the focus.

3.15.1 Epicentral Distance — The shortest distance from the epicentre to the site of interest along the surface of the earth.

3.16 Equivalent Static Method — A method of linear analysis of a structure to estimate the dynamic earthquake response considering the fundamental lateral mode of oscillation, using the pseudo-spectral acceleration response spectrum of the design earthquake hazard.

3.17 Floor Response Spectrum — The response spectrum (*see* 3.32) of the shaking induced at the floor of a structure, when the structure is subjected to a chosen earthquake ground shaking.

3.18 Focus — The point inside the earth where the earthquake rupture starts.

3.18.1 Focal Depth — The shortest distance between the focus and the epicentre.

3.19 Importance Factor (I) — A factor used in the estimation of the design earthquake force, which depends on the functional use of the structure, characterized by consequences of its failure, post-earthquake functional needs, historical value or economic importance.

3.20 Intensity of Earthquake — A measure of the severity of ground shaking manifested at a place during the earthquake, which is indicated by a roman capital numeral on the MSK scale of earthquake intensity (*see* Annex B).

3.21 Lithological Features — Attributes of the earth's cross-section, which reflect the nature of the geological formation of the earth's crust above the bedrock, and which are characterized based on structure, mineralogical composition and grain size.

3.22 Liquefaction — The state of soil (primarily in saturated or partially saturated cohesionless soil strata) wherein the shear strength of the soil decreases owing to increase in pore water pressure during earthquake shaking.

3.24 Magnitude — The number that characterizes the size of an earthquake and a measure of the energy released at the fault during the rupture and movement.

3.25 Modal Mass (M_k) in Natural Mode (k) of a Structure — A part of the total seismic mass of the structure that participates in natural mode k of oscillation during vibratory motion of the structure.

3.26 Modal Participation Factor (P_k) in Natural Mode (k) of a Structure — A factor that reflects the amount by which natural mode k contributes to overall oscillation of the structure during vibratory motion, which depends on the scaling used for defining mode shapes.

3.27 Natural Mode of Oscillation — The relative deformed shape of undamped free oscillations, in which all points on the structure oscillate harmonically at the same period, such that all these points reach their individual maximum deformed and undeformed configurations simultaneously with a fixed phase relation.

3.28 Natural Mode Shape Coefficient (ϕ_{ik}) — The spatial deformation pattern of oscillation along degree of freedom i , when the structure is oscillating in its natural mode k . A structure with N degrees of freedom possess N natural periods and N associated natural mode shapes. These natural mode shapes are together presented in the form of a mode shape matrix $[\phi]$, in which each column represents one natural mode shape. Element ϕ_{ik} of the mode shape matrix $[\phi]$ is called the mode shape coefficient associated with degree of freedom i , when structure oscillates in mode k .

3.29 Natural Period (T) of Natural Mode of Oscillation — Time taken by the structure to complete one cycle of oscillation in its natural mode of oscillation.

3.29.1 Fundamental Lateral Translational Natural Period (T_1) — The longest time taken by the structure to complete one cycle of oscillation in its first lateral translational mode of oscillation (with the entire structure swing back and forth in phase) in the considered horizontal direction in plan.

3.29.2 Natural Period (T_k) of Natural Mode (k) of Oscillation — The time taken by the structure to

complete one cycle of oscillation in its natural mode k of oscillation.

3.30 Peak Ground Acceleration — The maximum acceleration of the free surface of the ground along the horizontal or vertical direction of ground shaking.

3.31 Probabilistic Earthquake Hazard Assessment — The process of arriving at the earthquake hazard at a site considering the following aspects:

- a) Seismotectonics of the region;
- b) Likely maximum magnitude of the earthquake on each of the faults within a 300 km radius around the site;
- c) Potential fault mechanism and rupture plane characteristics;
- d) Attenuation of earthquake ground shaking along the path as it reaches the site from the source of fault rupture;
- e) Aleatoric uncertainties related to earthquake events; and
- f) Epistemic uncertainties related to the mathematical modelling of the considered region.

3.32 Response Amplification — The increase in the response of a structure or an *AEU* when the structure is subjected to an earthquake ground motion at its base, in comparison to the response when the force corresponding to the peak ground acceleration of the ground shaking is applied statically.

3.33 Response History Method — A method of linear analysis of a structure to estimate the dynamic earthquake response at each time instance, using a specific ground motion at its base.

3.34 Response Spectrum — The graphical representation of maximum responses (pseudo-acceleration, pseudo-velocity, or relative displacement) of idealized fixed-base single degree freedom systems (corresponding to a chosen structural damping) as a function of their corresponding natural periods when the same earthquake ground motion is imposed at their bases.

3.34.1 Pseudo-Spectral Acceleration (PSA) — The product of SD corresponding to natural period T and $(2\pi/T)^2$.

3.34.2 Pseudo-Spectral Velocity (PSV) — The product of SD corresponding to natural period T and $(2\pi/T)$.

3.34.3 Spectral Displacement (SD) — The maximum relative displacement of a single degree of freedom system of natural period T , when subjected to the earthquake ground shaking at its base.

3.35 Response Spectrum Method — A method of linear analysis of a structure to estimate its maximum dynamic earthquake response considering a few of its natural modes of oscillation, using the pseudo-spectral accelerations of the design earthquake hazard corresponding natural periods of the considered natural modes of oscillation.

3.36 Seismic Mass of a Floor — The seismic weight of the floor divided by acceleration due to gravity.

3.37 Seismic Mass of a Structure — The seismic weight of a structure above its base divided by acceleration due to gravity.

3.38 Seismic Waves — Waves produced in the body or surface of the earth through which mechanical energy generated by the earthquake is transmitted.

3.39 Seismic Weight of a Floor — The sum of dead load of the floor, appropriate contributions of weights of columns, walls, and any other permanent elements (including equipment, vessels, tanks, hoppers and containers) from the storeys above and below, finishes and services, and appropriate amounts of specified imposed load on the floor, which is ascribed to the floor of the structure.

3.40 Seismic Weight of a Structure — The sum of seismic weights of all floors (above the base) of the structure.

3.41 Shear Wave Velocity (V_s) — The weighted average of the shear wave velocity of the soil layers up to the depth of influence under the foundation.

3.42 Shear Wave Velocity up to 30 m depth (V_{S30}) — The weighted average of the shear wave velocity of the soil layers up to 30 m depth from the ground surface used in earthquake hazard assessment.

3.43 Uniform Hazard Response Spectrum — The response spectrum derived so that the annual probability of exceedance is the same at each natural period.

4 SYMBOLS AND ABBREVIATIONS

4.1 The symbols and notations given below shall apply to the provisions of this standard:

<i>Symbol</i>	<i>Description</i>	<i>Symbol</i>	<i>Description</i>
$A_H(T_H)$	Elastic maximum horizontal <i>PSA</i> corresponding to natural period T_H of the structure	$A_V(T_V)$	Elastic maximum vertical <i>PSA</i> corresponding to natural period T_V of the structure
$A_{HB}(T_H)$	Elastic maximum horizontal <i>PSA</i> corresponding to natural period T_H of the below ground structure	$A_{VB}(T_V)$	Elastic maximum vertical <i>PSA</i> corresponding to natural period T_V of the below ground structure
$A_{HD}(T_H)$	Design horizontal <i>PSA</i> corresponding to natural period T of the structure	$A_{VD}(T_V)$	Design vertical <i>PSA</i> corresponding to natural period T_V of the structure
A_{HF}	Horizontal plan area (in m ²) of the representative foundation element being considered at the level where the vertical normal and horizontal shear springs are provided	A_{VF}	Vertical projected area (in m ²) of the representative slice of the foundation element being considered at the level where the horizontal normal and vertical shear springs are provided
$A_{HSS}(T_H)$	Elastic maximum horizontal site-specific <i>PSA</i> corresponding to natural period T_H of the below ground structure	$A_{VSS}(T_V)$	Elastic maximum vertical site-specific <i>PSA</i> corresponding to natural period T_V of the below ground structure
$A_k(T_k)$	Horizontal <i>PSA</i> value corresponding to natural period T_k mode k of oscillation of the structure	a_{AEU}	Acceleration amplification factor of the <i>AEU</i>
$A_{NH}(T_H)$	Normalised horizontal <i>PSA</i> corresponding to natural period T_H of the structure	a_{max}	Maximum horizontal ground surface acceleration
$A_{NHB}(T_H)$	Normalised horizontal <i>PSA</i> corresponding to natural period T_H of the below ground structure	B	Horizontal dimension related to the foundation; and breadth of footing
$A_{NH,5\%}(T_H)$	Normalised horizontal <i>PSA</i> corresponding to natural period T_H of the structure at 5 percent of critical damping	B_{HF}	Equivalent horizontal projected dimension (in m) of the representative slice of the foundation element being considered at the level where the vertical normal and horizontal shear springs are provided
$A_{NV}(T_V)$	Normalised vertical <i>PSA</i> corresponding to natural period T_V of the structure	B_{VF}	Equivalent vertical projected dimension (in m) of the representative slice of the foundation element being considered at the level where the horizontal normal and vertical shear springs are provided
$A_{NVB}(T_V)$	Normalised vertical <i>PSA</i> corresponding to natural period T_V of the below ground structure	b_i	Plan dimension of floor i of the building, perpendicular to direction of earthquake shaking
$A_{NV,5\%}(T_V)$	Normalised vertical <i>PSA</i> corresponding to natural period T_V of the structure at 5 percent of critical damping	C_σ	Overburden stress correction coefficient
		c	Cohesion of soil; index for closely spaced modes
		$D_H(T_H)$	Elastic maximum horizontal SD corresponding to natural period T_H of the structure

<i>Symbol</i>	<i>Description</i>	<i>Symbol</i>	<i>Description</i>
$D_{HB}(T_H)$	Elastic maximum horizontal SD corresponding to natural period T_H of the below ground structure	EL_X	Response quantity due to earthquake load for horizontal shaking along X -direction
$D_{HD}(T_H)$	Design horizontal SD corresponding to natural period T_H of the structure	EL_Y	Response quantity due to earthquake load for horizontal shaking along Y -direction
$D_{HSS}(T_H)$	Elastic maximum horizontal site-specific SD corresponding to natural period T_H of the structure	EL_Z	Response quantity due to earthquake load for vertical shaking along Z -direction
DL	Response quantity due to dead load	F_{AEU}	Design lateral force for the design of such anchorages connecting acceleration-sensitive AEU's to the structural elements of the building
$D_{NH}(T_H)$	Normalised horizontal SD corresponding to natural period T_H of the structure	F_i	Design lateral forces at the floor i due to all modes considered
$D_{NHB}(T_H)$	Normalised horizontal SD corresponding to natural period T_H of the below ground structure	F_{roof}	Design lateral forces at the roof due to all modes considered
$D_{NH,5\%}(T_H)$	Normalised horizontal SD corresponding to natural period T_H of the structure corresponding to damping of 5 percent of critical damping	FS_{Liq}	Factor of safety against liquefaction
D_p	Diameter of pile	G_D	Dynamic shear modulus of elasticity of soil
D_R	Relative density of soil (in percent)	g	Acceleration due to gravity
$D_V(T_V)$	Elastic maximum vertical SD to natural period T_V of the structure	H	Overall height of the structure above top of the foundation
$D_{VD}(T_V)$	Design vertical SD corresponding to natural period T_V of the structure	H_i	Height measured from the base of the building to floor i ;
$D_{NV}(T_V)$	Normalised vertical SD corresponding to natural period T_V of the structure		Depth of soil layer i within the depth of influence, which is considered below natural ground level in different foundation conditions
$D_{NV,5\%}(T_V)$	Normalised vertical SD corresponding to natural period T_V of the structure corresponding to damping of 5 percent of critical damping	h_e	Depth of embedment of the structure from ground surface
d	Depth of the footing	I	Importance factor
E_D	Dynamic elastic modulus of soil	I_{AEU}	Importance factor of the AEU
$(EI)_p$	Flexural rigidity of pile	I_D	Material index
EL	Effect of design earthquake forces to be considered for design	IL	Response quantity due to imposed load
		K_D	Horizontal stress index
		K_i	Lateral translational stiffness of storey i
		K_σ	Overburden stress correction factor
		k_H	Modulus of subgrade reaction of soil in the horizontal direction to be used in estimating the

<i>Symbol</i>	<i>Description</i>	<i>Symbol</i>	<i>Description</i>
	horizontal normal springs for the foundation element	$(N_1)_{60}$	Stress-normalised penetration blow count, that is SPT 'N' corrected to energy ratio of 60 percent and an effective overburden stress that is equivalent to the pressure corresponding to 1 atmosphere
k_{HB}	Modulus of subgrade reaction of soil in horizontal bearing at the vertical face of the foundation element		
k_{HS}	Modulus of subgrade reaction of soil in horizontal shear at the bottom face of the foundation element	N_{cE}	Earthquake bearing capacity factor corresponding to cohesion of soil
k_{HO}	Basic modulus of subgrade reaction of soil in the horizontal direction to be used in horizontal normal springs for the foundation element of 0.3 m width considered during testing	N_m	Number of modes to be considered
		N_{qE}	Earthquake bearing capacity factors corresponding to surcharge on soil
k_h	Horizontal acceleration coefficient	$(N_1)_{60cs}$	Corrected SPT 'N' value for equivalent clean sand
k_v	Modulus of subgrade reaction of soil in the vertical direction to be used in estimating the vertical normal springs for the foundation element	$N_{\gamma E}$	Earthquake bearing capacity factors corresponding to unit weight of soil
		n	Number of storeys or floors
k_{VB}	Modulus of subgrade reaction of soil in vertical bearing at the bottom face of the foundation element	n^*	Stress exponent
		P_a	Atmospheric pressure
k_{VS}	Modulus of subgrade reaction of soil in vertical shear at the vertical face of the foundation element	P_k	Mode participation factor of mode k
k_{V0}	Basic modulus of subgrade reaction of soil in the vertical direction to be used in vertical normal springs for the foundation element of 0.3 m width considered during testing	p_0, p_1	Corrected dilatometer pressure readings corresponding to standard DMT readings A and B, respectively, which are corrected for membrane stiffness, gauge zero offset, and feeler pin elevation
k_v	Vertical acceleration coefficient	Q_i	Lateral shear force at floor i
L	Dimension of a building in a considered direction of earthquake shaking	Q_{ik}	Design lateral force at floor i in mode k
M	Magnitude of largest likely earthquake	Q_{tn}	Normalised tip resistance
M_k	Modal mass of mode k	q_{c1N}	Normalised overburden corrected cone tip resistance
M_w	Moment magnitude of earthquake	q_{c1Nes}	Equivalent clean-sand value of the corrected cone tip resistance
N	SPT value of soil	q_t	Cone tip resistance
N_E	SPT value of soil corrected for energy	q_{uE}	Ultimate bearing capacity of footing under earthquake condition
		R	Elastic force reduction factor
		R_{AEU}	Elastic force reduction factor of the AEU

<i>Symbol</i>	<i>Description</i>	<i>Symbol</i>	<i>Description</i>
r_d	Stress reduction factor	$V_{HSS}(T_H)$	Elastic maximum horizontal site-specific PSV corresponding to natural period T_H of the structure
r_u	Excess pore pressure ratio	V_i	Peak storey shear force in storey i due to all modes considered
S_i	Lateral shear strength of storey i	V_{ik}	Shear force in storey i in mode k
S_u	Undrained shear strength of soil	$V_{NH}(T_H)$	Normalised horizontal PSV corresponding to natural period T_H of the structure
T	Undamped natural period (in s) of oscillation of the structure	$V_{NH,5\%}(T_H)$	Normalised horizontal PSV corresponding to natural period T_H of the structure at 5 percent of critical damping
T_{AV}	Corner natural period (in s) demarcating the junction of the acceleration- and velocity-sensitive regions on the normalised pseudo-acceleration response spectrum	$V_{NHB}(T_H)$	Normalised horizontal PSV corresponding to natural period T_H of the below ground structure
T_a	Approximate fundamental period (in s)	V_{roof}	Peak storey shear force in the top storey due to all modes considered
T_{co}	Cut-off natural period (in s) corresponding to the natural period of the highest mode of the few modes considered	V_S	Shear wave velocity (in m/s) of soil layer
T_H	Horizontal natural period (in s) of the structure	V_{SD}	Dynamic shear wave velocity (in m/s) of soil layer
T_k	Undamped natural period (in s) of mode k of oscillation	$V_{s,30}$	Weighted average shear wave velocity (in m/s) of 30 m depth of soil stratum below bottom of founding level
T_R	Number of years, reciprocal of which gives the probability of extreme earthquake shaking at a site exceeding a given earthquake level in any one year	V_{s1}	Overburden stress corrected shear wave velocity (in m/s)
T_V	Vertical natural period (in s) of the structure	$V_V(T_V)$	Elastic maximum vertical PSV to natural period T_V of the structure
T_1	Fundamental natural period (in s) of oscillation	$V_{VD}(T_V)$	Design vertical PSV corresponding to natural period T_V of the structure
u_o	Pre-insertion in-situ equilibrium water pressure	$V_{NVB}(T_V)$	Normalised vertical PSV corresponding to natural period T_V of the below ground structure
V_{BD}	Design earthquake base shear	$V_{VSS}(T_V)$	Elastic maximum vertical site-specific PSV corresponding to natural period T_H of the structure
$\overline{V_{BD}}$	Design base shear calculated using approximate fundamental period T_a	$V_{NV}(T_V)$	Normalised vertical PSV corresponding to natural period T_V of the structure
$V_{BD,H}$	Design earthquake horizontal force at the base of the structure		
$V_{BD,V}$	Design earthquake vertical force at the base of the structure		
$V_H(T_H)$	Elastic maximum horizontal PSV corresponding to natural period T_H of the structure		
$V_{HD}(T_H)$	Design horizontal PSV corresponding to natural period T_H of the structure		

<i>Symbol</i>	<i>Description</i>	<i>Symbol</i>	<i>Description</i>
$V_{NV,5\%}(T_V)$	Normalised vertical <i>PSV</i> corresponding to natural period T_V of the structure at 5 percent of critical damping		Structure A at height h_1 from the base of the structure
x	Height of the point of attachment of <i>AEU</i> above top of the foundation of the structure	Δ_{X2}	Design horizontal displacement
W	Seismic weight of the structure	Δ_Y	Horizontal relative displacement along plan direction <i>Y</i> between two levels of a structure at which the <i>AEU</i> is supported
W_{AEU}	Weight of <i>AEU</i>	Δ_{YA1}	Design horizontal displacements along plan direction <i>Y</i> at level 1 of Structure A at height h_1 from the base of the structure
W_i	Seismic weight of floor i	Δ_{YB2}	Design horizontal displacements along plan direction <i>Y</i> at level 2 of Structure B at height h_2 from the base of the structure
Z	Earthquake zone factor, which reflects the mean horizontal peak ground acceleration (PGA) corresponding to a Return Period T_R (years) and the earthquake zone in which the structure lies	Δ_{Y1}	Design horizontal displacements along plan direction <i>Y</i> at level 1 of Structure A at height h_1 from the base of the structure
α	Parameter reflecting the static and dynamic actions in the estimation of stiffnesses of soil springs	Δ_{Y2}	Design horizontal displacements along plan direction <i>Y</i> at level 2 of Structure A at height h_2 from the base of the structure
α_{AE}	Inclination angle for active earth pressure conditions	Δ_Z	Vertical relative displacement along vertical direction <i>Z</i> between two levels of a structure at which the <i>AEU</i> is supported
α_{PE}	Inclination angles for passive earth pressure conditions	Δ_{ZA1}	Design vertical displacements along vertical direction <i>Z</i> at level 1 of Structure A at height h_1 from the base of the structure
β	Relative stiffness parameter of pile-soil system	Δ_{ZB2}	Design vertical displacements along vertical direction <i>Z</i> at level 2 of Structure B at height h_2 from the base of the structure
γ	Unit weight of soil	Δ_{Z1}	Design vertical displacements along vertical direction <i>Z</i> at level 1 of Structure A at height h_1 from the base of the structure
Δ_{cIN}	Correction for fines content in CPT	Δ_{Z2}	Design vertical displacements along vertical direction <i>Z</i> at level 2 of Structure A at height h_2 from the base of the structure
$\Delta(N_1)_{60}$	Correction for fines content in SPT	δ	Wall friction angle
Δ_X	Horizontal relative displacement along plan direction <i>X</i> between two levels of a structure at which the <i>AEU</i> is supported		
Δ_{XA1}	Design horizontal displacements along plan direction <i>X</i> at level 1 of Structure A at height h_1 from the base of the structure		
Δ_{XB2}	Design horizontal displacements along plan direction <i>X</i> at level 2 of Structure B at height h_2 from the base of the structure		
Δ_{X1}	Design horizontal displacements along plan direction <i>X</i> at level 1 of		

<i>Symbol</i>	<i>Description</i>
θ	Horizontal-to-vertical earthquake acceleration intensity ratio
λ	Estimate of peak response (for example member forces, displacements, storey forces, storey shears or base reactions) due to all modes considered.
λ^*	Estimate of peak response due to the closely-spaced modes only
λ_c	Absolute value of maximum estimated response in mode c , where c is number of the closely-spaced modes
λ_k	Absolute value of maximum estimated response in mode k
ξ	Modal damping coefficient ratio which shall be taken as 0.05, unless stated otherwise
ν and ν_s	Poisson's ratio of soil
ρ	Mass density of soil (kg/m^3)
ρ_{AE}	Critical angle of rupture under active condition
ρ_{ij}	Cross-modal correlation coefficient used in complete quadratic combination (CQC) Method when combining responses of modes i and j
ρ_{PE}	Critical angle of rupture under passive condition
σ_{vc}	Total vertical consolidation stress
σ_{v0}	Total vertical overburden stress
σ'_{vc}	Effective vertical consolidation stress
σ'_{vce}	Effective vertical consolidation stress
σ'_{v0}	Effective vertical overburden stress at the chosen depth in the potentially liquefiable layers within the deposit
ϕ	Angle of repose or friction angle of soil
ϕ_{ik}	Mode shape coefficient at floor i in mode k
Ω	Overstrength factor, reflecting the ratio of maximum lateral resistance offered by the

<i>Symbol</i>	<i>Description</i>
	structure and the design lateral force
ω_i	Circular frequency in mode i

When other symbols are used, they are explained at the appropriate place. Unless otherwise specified, all dimensions are in millimetres (mm), force in newton (N), stresses in mega pascal (MPa) and time in seconds (s).

4.2 The abbreviations given below apply to this standard:

<i>Abbreviation</i>	<i>Full Expanded Form</i>
<i>AEU</i>	Architectural element and utility
<i>A-AEU</i>	Acceleration-sensitive AEU
<i>D-AEU</i>	Displacement-sensitive AEU
<i>AD-AEU</i>	Acceleration-cum-displacement-sensitive AEU
<i>CPT</i>	Cone penetration test
<i>CRR</i>	Cyclic resistance ratio
<i>CRR_{M_w=7.5,σ'_v=1atm}</i>	CRR corresponding to a standard reference condition of $M_w = 7.5$ and σ'_v of 1 atmosphere
<i>CSR</i>	Cyclic stress ratio
<i>DEHA</i>	Deterministic earthquake hazard assessment
<i>DMT</i>	Dilatometer test
<i>FC</i>	Fines content
<i>MSF</i>	Magnitude scaling factor
<i>OCR</i>	Over-consolidation stress ratio
<i>PEHA</i>	Probabilistic earthquake hazard assessment
<i>PGA</i>	Peak ground acceleration
<i>PI</i>	Plasticity index
<i>PSA</i>	Pseudo-spectral acceleration
<i>PSV</i>	Pseudo-spectral velocity
<i>SD</i>	Spectral displacement
<i>SPT</i>	Standard penetration test

5 GENERAL PRINCIPLES

5.1 Site Selection

The site selected to construct a structure shall neither liquefy nor slide during design earthquake shaking specified in this standard.

5.1.1 Liquefaction

5.1.1.1 The provisions of 9.2 shall be employed to evaluate the potential of a site to liquefy.

5.1.1.2 A site, which is likely to liquefy, shall not be considered as a potential site as, unless suitable ground improvement techniques are adopted.

5.1.2 Landslides

5.1.2.1 The method provided in IS 17162 shall be employed to evaluate the potential of a site to landslides.

5.1.2.2 A site, which is likely to sustain a landslide, shall not be considered as a potential site, unless suitable landslide mitigation techniques are adopted to resist the impact of the sliding of the large mass of the structure.

5.2 Ground Motions

The characteristics (namely amplitude, frequency content, and duration) of the random earthquake ground vibrations at a site depend on:

- a) source effects (reflecting magnitude of earthquake, its focal depth, slip, near-fault effects);
- b) path effects (reflecting epicentral distance, and characteristics of the medium through which the earthquake waves travel); and
- c) site effects (reflecting soil strata on which the structure is founded).

These earthquake ground vibrations, which oscillate the structure, have three components oriented along three mutually perpendicular directions.

5.2.1 Far-Fault Effects

The predominant direction of ground vibration is horizontal in the far-fault region. Far-fault earthquake shaking does not contain pulse-like ground motions.

5.2.2 Near-Fault Effects

The horizontal and vertical shakings are comparable in the near-fault regions. Near-fault

earthquake shaking contains pulse-like ground motions.

5.2.2.1 Design spectrum

The provisions of this standard do not account for near-fault ground motions in the design spectrum when performing earthquake-resistant design of structures located in the vicinity of faults. But, the near-fault ground motions are accounted for when using the response history methods. Hence, additional precautions shall be taken to account for the near-fault effects to enhance the earthquake capacity of structures.

5.2.2.2 Assessment of behaviour

The provisions of this standard account for near-fault ground motions, in the assessment of earthquake behaviour of structures.

5.2.3 Spatial Variation

5.2.3.1 Uniform ground motion

In the design of structures whose footprint is small in comparison with the wavelength of the surface waves generated during earthquake shaking, the ground motion shall be the same at all supports of the structures.

5.2.3.2 Non-uniform ground motion

In the design of structures whose footprint is comparable to the wavelength of the surface waves generated during earthquake shaking, the ground motion shall be different at the supports of structures. The provisions of this standard do not address this. Hence, special ground motions shall be considered in such situations.

5.2.4 Vertical Ground Motions

The effects of earthquake-induced vertical shaking (that is, increase and decrease in gravity forces) can be significant for the overall safety of structures, especially in:

- a) structures with large span beams and slabs;
- b) structures in which stability is a criterion for design;
- c) structures with prestressed horizontal members;
- d) structures with cantilevered members; and
- e) gravity structures.

Hence, special attention shall be paid to estimate the effects of vertical ground motion on such structures.

5.3 Earthquake Effects on Structures

5.3.1 Design Forces

The response of a structure to ground vibrations depends on:

- a) soil strata underneath;
- b) type of foundation;
- c) materials, form, size, and mode of construction of the structure; and
- d) amplitude, frequency content and duration of ground motion. This standard specifies design forces for structures founded on rocks or soils that do not liquefy, or on those that do not slide due to loss of strength during earthquake ground vibrations.

In earthquake Zones III, IV, V and VI, even when the design horizontal base shear of a structure arising from earthquake load effects specified by this standard is less than those from other lateral loads (like wind), the structure shall be designed and detailed as per the provisions of this standard and of IS 13920.

5.3.2 Inelastic Behaviour

Structures can be designed to resist the effects of earthquake shaking to behave either elastically (in the special category of structures) or inelastically (in the normal category of structures); this standard provides guidance for the design of structures to remain elastic and inelastic.

When earthquake-resistant design relies on inelastic behaviour of structures, the actual forces that appear on structures during earthquakes can be much higher than the design forces specified in the standard, and they can induce damage in the structure. In such a case, three aspects are relied upon for overcoming the difference between actual and design lateral loads, namely:

- a) Ductility arising from inelastic structural behaviour with appropriate design and detailing;
- b) Overstrength arising from the additional reserve strength in structures over and above the design strength (owing to partial safety factors employed on material strengths and strain hardening in materials); and

- c) Redistribution of forces to different members arising from redundancy (owing to flow of earthquake induced effects from more damaged members to less damaged ones).

For this reason, even if for some structures, load combinations that do not include earthquake loads may indicate larger demands than combinations that include earthquake loads, the requirements of this standard for earthquake-resistant design, detailing, and construction to realize the ductile behaviour shall be satisfied. Further, the maximum ductility that can be realized in structures is limited. Therefore, structures with inelastic behaviour shall be designed for at least the minimum design lateral force specified in this standard to mitigate the effects of local or global damage, as specified in respective parts of IS 1893.

5.3.3 Floor Response Spectrum

Equipment and other systems, which are supported at various floor levels of a structure, will be subjected to different motions at their support points. In such cases, it may be necessary to obtain floor response spectra for the design of equipment and its supports. For details, reference may be made to IS 1893 (Part 4).

5.4 Soil Structure Interaction

Soil-structure interaction refers to two effects of the supporting soil-foundation system on the response of the superstructure, namely flexibility of the soil strata underneath and inertia forces of the mass of the soil-foundation system. This standard provides requirements to account for the effects of:

- a) the flexibility of the soil stratum or strata underneath the structure; and
- b) the inertia of the mass of the soil-foundation system underneath the structure, in the earthquake analysis of structures as specified in this standard, except when structures are supported on sites of site class A and site class B, or if shallow foundations are adopted.

5.5 Classification of Structures

Structures shall be categorised as specified hereunder.

5.5.1 Categories of Structures

Based on the relative severity of the negative consequences (that is, losses of life and livestock, losses of property and harm to natural

environment) in the event of failure of a structure, structures are classified into four categories, namely:

- a) Normal structures;
- b) Important structures;
- c) Critical structures; and
- d) Special structures.

5.5.2 Types of Structures

Based on their functionality, structures shall be classified into 11 types, namely liquid-retaining structures, bridges, industrial structures, buildings, base-isolated buildings, long-distance pipelines, dams (earthen, concrete and masonry dams), steel towers, coastal structures, tunnels, and earth-retaining structures, as specified in IS 1893 (Part 2) to (Part 12), respectively.

5.6 Performance Expectation

- a) This standard provides the minimum requirements for earthquake-resistant design of normal and important category of structures. In the design of critical or special category of structures, rigorous site-specific investigations may be necessary to arrive at the design of earthquake hazard more accurately than that specified in this standard for normal and important structures;
- b) When base-isolation devices are employed in buildings, the intent is not to reduce the cost of construction, but to improve their performance during earthquakes. Reference may be made to IS 1893 (Part 6) for designing, detailing, installing and maintaining such buildings. Specialist literature should be consulted for designing, detailing, installing and maintaining energy dissipation devices in buildings and other structures;
- c) Structures designed as per this standard are expected to sustain:
 - 1) Structural damage during design earthquake ground shaking, even if the said minimum requirements for earthquake-resistant design are complied with; and
 - 2) Reduced structural damage when base-isolators or energy dissipation devices are built into them.

5.6.1 Damage

When a structure is designed as per this standard, IS 13920 (Part 1), and respective part of IS 1893

and IS 13920 depending on the type of the structure, to sustain damage, the following shall be ensured in its design to enhance its ductile behaviour:

- a) All brittle modes of damage shall be precluded from occurring before the occurrence of the ductile modes of damage;
- b) A predetermined desirable collapse mechanism in the primary structural system shall be considered and the same be ensured through providing acceptable strength hierarchy within each member and between adjoining members;
- c) The location of damage within horizontal and vertical members shall be such that they permit global ductile response of structures; and
- d) Base-isolation system or energy dissipation devices, when used, may alleviate damage in structural elements under the design level earthquake shaking, and enhance the functional performance of the structure.

5.6.2 Integrity

It is desirable that the primary lateral force-resisting system (LFRS) maintains the required integrity under design earthquake shaking specified in this standard and does not undergo undesirable structural performance. Therefore, under strong design earthquake shaking, the structure (or a part thereof) designed as per provisions of this standard should be robust enough and have the following:

- a) Structural system with:
 - 1) Clearly identifiable load paths through structural elements up to the foundation, which can resist global lateral deformation without collapse;
 - 2) Redundancy, where possible, facilitating redistribution of loads to remaining adjoining members, when one or more members exceed the design strength;
 - 3) Structural elements (in which the demands are likely to exceed the corresponding design strengths) having sufficient overstrength and plastic deformation capacity to rotate inelastically, and redistribute the loads to remaining members of the structure;

- 4) Other structural elements capable of carrying the additional redistributed loads and load effects induced in them, either elastically or inelastically, but without exceeding their inelastic deformability; and
 - 5) Reduced chances of collapse of either the complete structure (that is, global collapse) or a part of it (that is, local collapse);
- b) Connections between members designed to withstand the extreme load actions transmitted through them, when the structure is in the state of desirable collapse mechanism, including the effects of overstrength of the adjoining members that sustain inelastic actions; and
 - c) A foundation that can withstand the extreme forces transmitted through them without significant damage, including the effects of overstrength of the structural system and other members along the load paths, when the structure is in the state of desirable collapse mechanism.

5.6.2.1 Desirable collapse mechanism

- a) Desirable collapse mechanism is a state of the structure in which:
 - 1) select structural elements of the LFRS are designed and detailed to behave in a ductile manner without any undue concentration of plastic rotational demand in any one member, and the other structural members are designed and detailed to behave in a manner without exceeding their design strength capacities; and
 - 2) a large part of the input earthquake energy is absorbed through ductile (inelastic) behaviour.
- b) For each structure type, there are limited possibilities of desirable collapse mechanisms; the same should be identified before designing the members, connections, and foundations. The desirable collapse mechanism should be identified at the design stage itself considering overstrength and design strength properties of all structural elements.

5.6.2.2 Key elements

- a) Key elements are members, which when lost during the action of strong earthquake

shaking, result in disproportionately large damage to or even collapse of structures, especially vertical members and cantilever beams. They should be identified by:

- 1) Removing one member at a time from the structure;
 - 2) Performing structural analysis of the residual structure; and
 - 3) Examining the remaining structure for large deformation demands or damage corresponding to each design action (namely axial force, shear force, bending moment and torsional moment) induced by the applicable loads.
- b) The method of analysis should be large-displacement small-strain nonlinear analysis, including both geometric and material nonlinearities. Nonlinear analyses are sensitive to the input parameters. Hence, competence and experience in the subject shall be ensured in the personnel performing these analyses and using the results with judgment;
 - c) The key elements should be identified at the design stage itself, and designed and detailed to comply with the requirements of IS 13920 (Part 1) and of IS 13920 (Part 2 to Part 12) depending on the type of the structure. They should be designed to withstand the design demands by conservative design approaches based on sound engineering principles, including but not limited to, the use of additional safety factors for structural elements and R values reduced by 50 percent, but not less than 1.0; and
 - d) The key elements shall be suitably identified and designed in critical and special structures in all earthquake zones; this is recommended in important structures. When key elements are considered, their impact should be addressed on AEU's also.

6 DESIGN EARTHQUAKE HAZARD

6.1 Earthquake Ground Shaking

The earthquake ground shaking expected at a site to be used in the design of structures is described in terms of:

- a) the design PSA response spectra to be used in the estimation of design

earthquake forces specified in **6.2** and **6.3**; and

- b) the design ground acceleration histories to be use in the response history analysis specified in **8.3.3.3(d)(1)**.

6.1.1 Horizontal and Vertical Shaking Effects

The horizontal and vertical effects of earthquake ground shaking shall be considered in the design of structures as specified in **6.2** and **6.3**.

6.2 Design Earthquake Hazard

The design earthquake horizontal force $V_{BD,H}$ at the base of the structure and the design earthquake vertical force $V_{BD,V}$ at the base of the structure considering the PSA spectrum shall be estimated as:

$$V_{BD,H} = A_{HD}W = \frac{Z I A_{NH}(T_H)}{R} W, \text{ and}$$

$$V_{BD,V} = A_{VD}W = Z I A_{NV}(T_V) W$$

where

- A_{HD} = design horizontal acceleration coefficient of the structure;
- W = seismic weight of the structure taken as per **8.2.1**;
- Z = earthquake zone factor taken as per **6.2.2.2**;
- I = importance factor taken as per **8.2.2**;
- A_{NH} = normalised horizontal spectral acceleration of the structure taken as per **6.2.3.2** and **6.2.3.3**;
- R = elastic force reduction factor taken as per **8.2.3**;
- A_{VD} = design vertical acceleration coefficient of the structure; and
- A_{NV} = normalised vertical spectral acceleration of the structure

taken as per **6.2.3.2** and **6.2.3.3**.

In this standard, the term design base force V_{BD} is used to collectively refer to $V_{BD,H}$ and $V_{BD,V}$.

6.2.1 Earthquake Zones

The Indian landmass is demarcated into five earthquake zones, namely Zones II, III, IV, V and VI (see Fig. 1). A list of select towns and their earthquake zones is provided in Annex D.

6.2.2 Design Earthquake Peak Ground Acceleration

The peak ground acceleration to be used in the design of structures shall be estimated using the provisions given hereunder.

6.2.2.1 Return periods for each category of structures

- a) The earthquake zone factor Z to be used in the design of the four categories of structures (identified in **5.3.1**) shall be based on the corresponding return period T_R specified in:
- 1) Table 1 for structures designed by the limit state method; and
 - 2) Table 2 for structures designed by the working stress method.
- b) Structures not listed in Table 1 and Table 2 shall be considered as normal structures, and designed for the corresponding effects specified in this standard, unless stated otherwise by Statutory Authorities.
- c) The details of types of structures are given in the respective part of IS 1893 depending on the type of structure.

6.2.2.2 Earthquake zone factor

The earthquake zone factor (Z) corresponding to different return period (T_R) in each earthquake zone shall be taken as per Table 3.

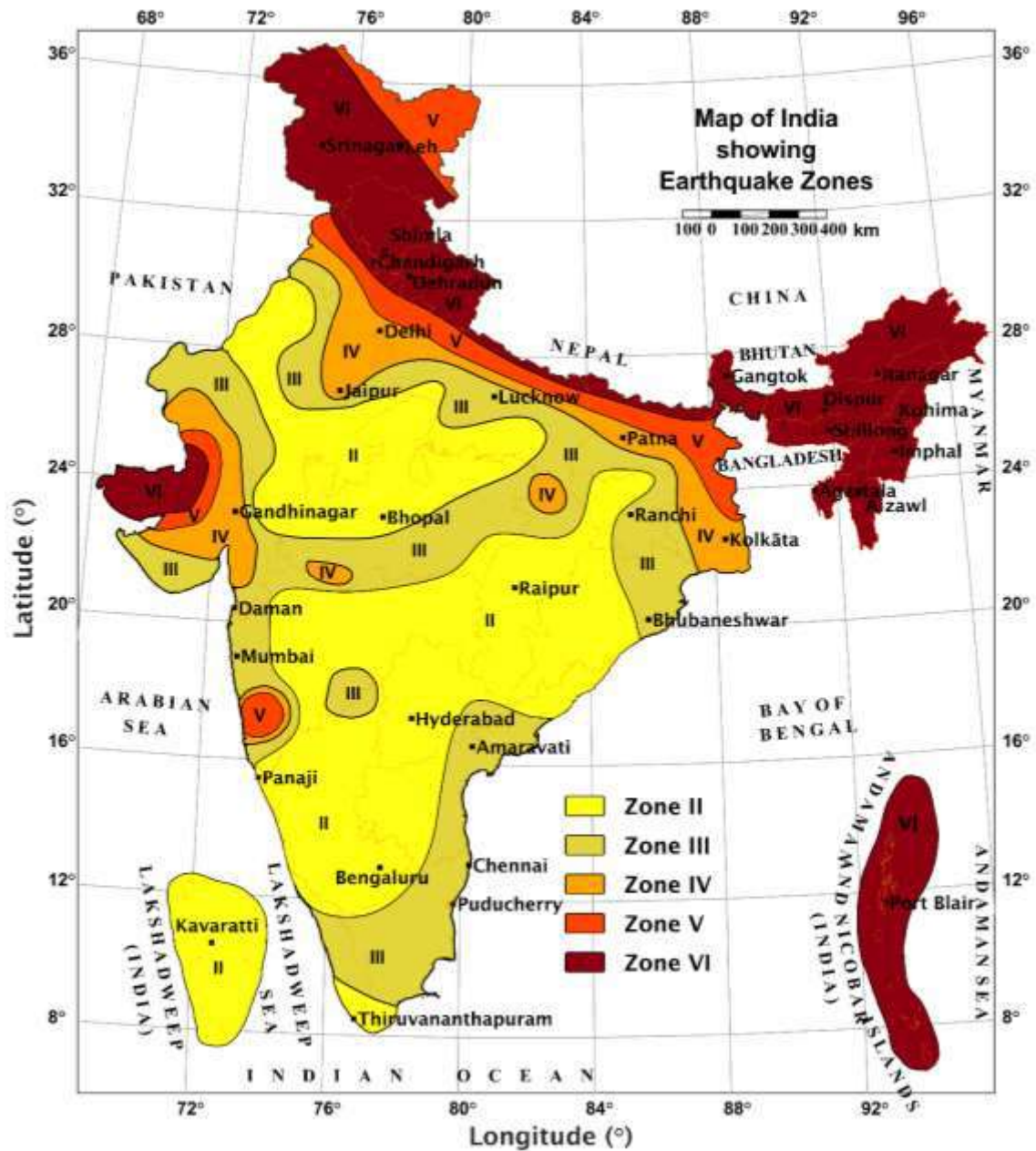

NOTES

- 1 This map is based upon Survey of India Political map printed in 2002.
- 2 The territorial waters of India extend into the sea to twelve nautical miles from the appropriate baseline.
- 3 The interstate boundaries between Arunachal Pradesh, Assam and Meghalaya shown on this map are as interpreted from the *North-Eastern Areas (Reorganization) Act, 1971*, but have yet to be verified.
- 4 The state boundaries between Uttarakhand and Uttar Pradesh, Bihar and Jharkhand, and Chhattisgarh and Madhya Pradesh have not been verified by the Governments concerned.
- 5 The responsibility for the correctness of internal details rests with the publisher.
- 6 For details regarding the up-to-date seismic activity (plotted on the Map of India), please visit the online portal of the National Centre for Seismology (NCS), Ministry of Earth Sciences, New Delhi.
- 7 Town falling at the boundary of zones demarcation line between two zones shall be considered in higher zone.

FIG. 1 MAP OF INDIA SHOWING EARTHQUAKE ZONES

Table 1 Return Period T_R to be Used in the Design of Different Categories of Structures Designed by Limit State Method

(Clauses 6.2.2.1, 6.2.3.4 and 8.2.4)

SI No.	Category of Structure	Structure Type	Return Period T_R (in Years)
(1)	(2)	(3)	(4)
i)	Special	a) Special liquid-retaining structures	4 975
		b) Special bridges	
		c) Special industrial structures	
		d) Special concrete and steel buildings	
		e) Special base-isolated buildings	
		f) Special long-distance pipelines	
		g) Special steel towers	
		h) Special coastal structures	
		j) Special tunnels	
		k) Select structures to be designed by limit state method identified by statutory authorities having jurisdiction	
		ii)	
b) Critical bridges			
c) Critical industrial structures			
d) Critical concrete and steel buildings			
e) Critical base-isolated buildings			
f) Critical long-distance pipelines			
g) Critical steel towers			
h) Critical coastal structures			
j) Critical tunnels not covered in special tunnels			
iii)	Important		a) Important liquid-retaining structures
		b) Important bridges	
		c) Important industrial structures	
		d) Important concrete and steel buildings	
		e) Important long-distance pipelines	
		f) Important steel towers not covered in critical steel towers	
		g) Important coastal structures not covered in critical coastal structures	
iv)	Normal	a) Important liquid-retaining structures	475
		b) Important bridges	
		c) Important industrial structures	
		d) Important concrete and steel buildings	
		e) Important long-distance pipelines	

Table 2 Return Period T_R to be Used in the Design of Different Categories of Structures Designed by Working Stress Method

(Clauses 6.2.2.1 and 6.2.3.4)

SI No.	Category of Structure	Structure Type	Return Period T_R (in Years)
(1)	(2)	(3)	(4)
i)	Special	a) Special masonry buildings	975
		b) Special dams	
		c) Special earth-retaining structures	
		d) Select structures to be designed by working stress method identified by statutory authorities having jurisdiction	
ii)	Critical	a) Critical masonry buildings	475
		b) Critical dams	
		c) Critical earth-retaining structures	
iii)	Important	a) Important masonry buildings	275
		b) Important dams	
		c) Important earth-retaining structures	
iv)	Normal	a) Normal masonry buildings	175
		b) Normal dams	
		c) Normal earth-retaining structures	

Table 3 Earthquake Zone Factor (Z) for Different Return Periods (T_R) in Different Earthquake Zones

(Clause 6.2.2.2)

SI No.	Earthquake Zone	Design Earthquake Zone Factor (Z) for Different Return Periods T_R (in Years)								
		75	175	275	475	975	1 275	2 475	4 975	9 975
(1)	(2)	(3)	(4)	(5)	(6)	(7)	(8)	(9)	(10)	(11)
i)	VI	0.300	0.375	0.450	0.500	0.600	0.6250	0.75	0.940	1.125
ii)	V	0.200	0.250	0.300	0.333	0.400	0.4167	0.50	0.625	0.750
iii)	IV	0.140	0.175	0.210	0.233	0.280	0.2917	0.35	0.440	0.525
iv)	III	0.0625	0.085	0.100	0.125	0.167	0.1875	0.25	0.333	0.450
v)	II	0.0375	0.050	0.060	0.075	0.100	0.1125	0.15	0.200	0.270

6.2.3 Elastic Pseudo-Acceleration, Pseudo-Velocity and Displacement Response Spectra

The elastic response spectra described hereunder shall be used to specify the design earthquake hazard.

6.2.3.1 Site class

- a) The site of a structure shall be placed under one of the site classes presented in Table 4, based on the weighted average V_S of the individual values V_{Si} underlying soil strata i , where i belongs to $[1, N_L]$, in which N_L is the number of soil layers considered. The weighted average V_S considered over the depth of influence on the underlying soil layers below the founding level, which is considered below natural ground level (NGL) in different foundation conditions as per Table 5, shall be estimated as:

$$V_S = \frac{\sum_{i=1}^{N_L} H_i}{\sum_{i=1}^{N_L} \left(\frac{H_i}{V_{Si}} \right)}$$

where

- N_L = number of soil layers within the depth of influence, specified in 6.2.3.1(c) and 6.2.3.1(d);
 H_i = depth (in m) of soil layer i within the depth of influence; and
 V_{Si} = shear wave velocity (in m/s) of soil layer i .

- b) The shear wave velocity V_{Si} (m/s) of each layer i at the site of:
- 1) normal structures in all earthquake zones; and
 - 2) important structures in earthquake Zones II and III, may be estimated by the following approximate correlation:

$$V_{Si} = \begin{cases} 80[(N_1)_{60i}]^{0.5} & \text{for dry sands (fines content less than 15 percent)} \\ 80[(N_1)_{60i}]^{0.4} & \text{for saturated sands (fines content less than 15 percent)} \\ 80[(N_1)_{60i}]^{0.3} & \text{for clays} \end{cases}$$

where $(N_1)_{60i}$ is the SPT value of the layer i corrected to address the field procedure adopted and the overburden. For sands with fines content more than 15 percent, V_{Si} can be taken as that given by the expression for clays. These correlations are not applicable when $(N_1)_{60i}$ is less than 10; in such cases, detailed field investigations shall be employed to estimate the shear wave velocity;

- c) The depth of investigation shall be taken as the depth of influence specified in Table 5;
- d) The shear wave velocity V_{Si} of soil layer i at the site of the structure shall be estimated by geophysical investigations:
- 1) In important structures in earthquake Zones IV, V and VI, up to the depth of influence specified in Table 5, or 10 m measured from below the founding level, whichever is larger;
 - 2) In critical structures in all earthquake zones, up to the depth of influence specified in Table 5, or 20 m, measured from below the founding level, whichever is larger; and
 - 3) In special structures in all earthquake zones, up to the depth of influence specified in Table 5, or 30 m, measured from below the founding level, whichever is larger.

In all the above, investigations shall be stopped when bedrock or hard rock is encountered before reaching the said depths of influence mentioned above.

- e) When foundations rest on river beds, the natural ground level shall be considered at the ground level after maximum scour occurs.

Table 4 Site Classes for Estimating Normalised PSA

[Clause 6.2.3.1(a)]

Sl No.	Site Class	Weighted Average Shear Wave Velocity V_s (m/s)
(1)	(2)	(3)
i)	A	$1\ 500 \leq V_s$
ii)	B	$760 \leq V_s < 1\ 500$
iii)	C	$360 \leq V_s < 760$
iv)	D	$180 < V_s < 360$
v)	E	$V_s \leq 180$

Table 5 Depth of Influence in Underlying Soil Layers to be Considered, Measured from below the Founding Level

[Clause 6.2.3.1(c)]

Sl No.	Type of Foundation	Depth of Influence
(1)	(2)	(3)
i)	Spread footing (individual, strip or combined)	$2B$, where B = smaller plan dimension of spread footing
ii)	Mat	$2B$, where B = smaller plan dimension of the mat
iii)	Pile	$H_p + 2D_p$, where H_p = depth below natural ground of the pile tip, or up to bedrock, whichever is lesser; and D_p = diameter of the pile, when bedrock is not encountered by the pile, and 0 when bedrock is encountered by the pile group.
iv)	Pile group	$H_{pg} + 2B$, where H_{pg} = depth below natural ground of the tip of deepest pile, or up to bedrock, whichever is lesser; and B = distance between outer edges of the outermost piles in the pile group in the considered direction of earthquake shaking, when bedrock is not encountered by the pile group, and 0 when bedrock is encountered by the pile group.
v)	Well	$H_w + 2B$, where H_w = height below natural ground level of well foundation, or up to bedrock, whichever is lesser; and B = smaller plan dimension of well foundation.

6.2.3.2 Normalised elastic maximum horizontal and vertical PSA, PSV and SD corresponding to damping ratio of 5 percent of critical damping

The normalised elastic maximum *PSA*, *PSV* and *SD* along horizontal and vertical directions corresponding to damping of 5 percent of critical damping, for site class A to class D, shall be obtained as specified hereunder. No normalised horizontal or vertical *PSA*, *PSV* and *SD* spectra are provided for site class E; in such cases, site-specific hazard assessment (as per 6.3) shall be performed to estimate the normalised horizontal and vertical spectra.

a) *Above ground*

For a viscous damping ratio (ξ) of 5 percent of critical damping, the normalised horizontal *PSA* $A_{NH,5\%}(T_H)$ for the structure or the portions of the structure above ground in projects constructed on site classes A, B, C and D, shall be taken as specified hereunder for different methods of analysis (see Fig. 2).

1) *Static Analysis – Equivalent static method:*

$$A_{NH,5\%}(T_H) = \begin{cases} \begin{cases} 2.5 & 0 < T_H \leq 0.4 \text{ s} & \text{site classes A and B} \\ \left(\frac{1}{T_H}\right) & 0.4 \text{ s} < T_H \leq 6.0 \text{ s} \\ \left(\frac{6}{T_H^2}\right) & 6.0 \text{ s} < T_H \leq 10.0 \text{ s} \end{cases} \\ \begin{cases} 2.5 & 0 < T_H \leq 0.6 \text{ s} & \text{site class C} \\ \left(\frac{1.5}{T_H}\right) & 0.6 \text{ s} < T_H \leq 6.0 \text{ s} \\ \left(\frac{9}{T_H^2}\right) & 6.0 \text{ s} < T_H \leq 10.0 \text{ s} \end{cases} \\ \begin{cases} 2.5 & 0 < T_H \leq 0.8 \text{ s} & \text{site class D} \\ \left(\frac{2.0}{T_H}\right) & 0.8 \text{ s} < T_H \leq 6.0 \text{ s} \\ \left(\frac{12}{T_H^2}\right) & 6.0 \text{ s} < T_H \leq 10.0 \text{ s} \end{cases} \end{cases}$$

$$A_{NV,5\%}(T_V) = \delta_v(T_V) \begin{cases} \begin{cases} 2.5 & 0 < T_V \leq 0.4 \text{ s} & \text{site classes A and B} \\ \left(\frac{1}{T_V}\right) & 0.4 \text{ s} < T_V \leq 6.0 \text{ s} \\ \left(\frac{6}{T_V^2}\right) & 6.0 \text{ s} < T_V \leq 10.0 \text{ s} \end{cases} \\ \begin{cases} 2.5 & 0 < T_V \leq 0.6 \text{ s} & \text{site class C} \\ \left(\frac{1.5}{T_V}\right) & 0.6 \text{ s} < T_V \leq 6.0 \text{ s} \\ \left(\frac{9}{T_V^2}\right) & 6.0 \text{ s} < T_V \leq 10.0 \text{ s} \end{cases} \\ \begin{cases} 2.5 & 0 < T_V \leq 0.8 \text{ s} & \text{site class D} \\ \left(\frac{2.0}{T_V}\right) & 0.8 \text{ s} < T_V \leq 6.0 \text{ s} \\ \left(\frac{12}{T_V^2}\right) & 6.0 \text{ s} < T_V \leq 10.0 \text{ s} \end{cases} \end{cases}$$

where

$$\delta_V(T_V) = \begin{cases} 0.80 & T_V \leq 0.01 \text{ s} \\ 0.80 - \left(\frac{200}{135}\right)(T_V - 0.01) & 0.01 \text{ s} < T_V \leq 0.10 \text{ s} \quad \text{site classes A and B} \\ 0.67 & 0.10 \text{ s} < T_V \end{cases}$$

$$\delta_V(T_V) = \begin{cases} 0.82 & T_V \leq 0.01 \text{ s} \\ 0.82 - \left(\frac{213}{125}\right)(T_V - 0.01) & 0.01 \text{ s} < T_V \leq 0.10 \text{ s} \quad \text{site class C} \\ 0.67 & 0.10 \text{ s} < T_V \end{cases}$$

$$\delta_V(T_V) = \begin{cases} 0.85 & T_V \leq 0.01 \text{ s} \\ 0.85 - \left(\frac{200}{100}\right)(T_V - 0.01) & 0.01 \text{ s} < T_V \leq 0.10 \text{ s} \quad \text{site class D} \\ 0.67 & 0.10 \text{ s} < T_V \end{cases}$$

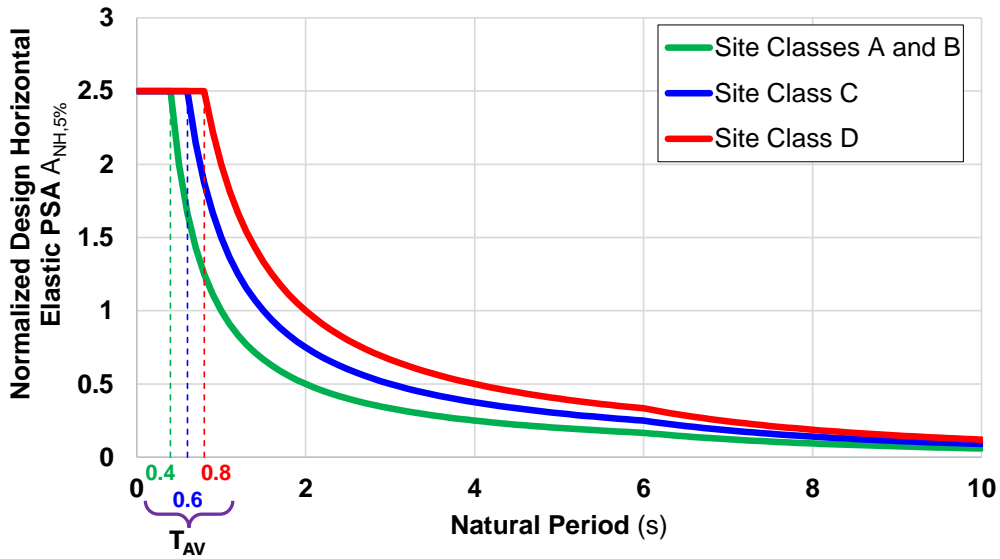

FIG. 2(A) EQUIVALENT STATIC METHOD

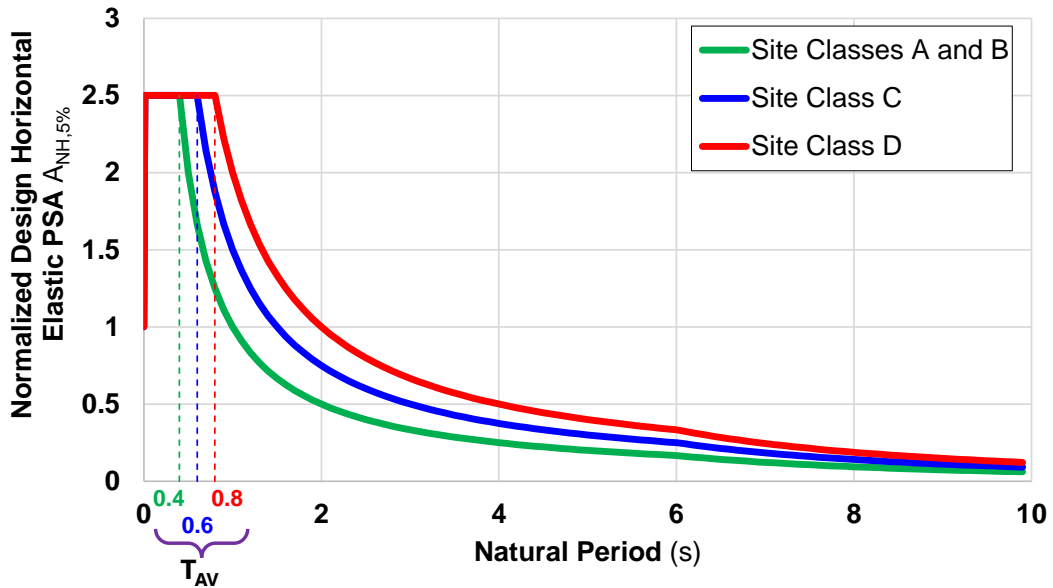

FIG. 2(B) RESPONSE SPECTRUM METHOD

FIG. 2 NORMALISED HORIZONTAL ELASTIC $PSA A_{NH,5\%}(T)$ (FOR 5 PERCENT DAMPING) FOR DIFFERENT SITE CLASSES FOR USE IN: (A) EQUIVALENT STATIC METHOD, AND (B) RESPONSE SPECTRUM METHOD

2) *Dynamic analysis — response spectrum method:*

$$A_{NH,5\%}(T_H) = \begin{cases} \begin{cases} 1.0 & 0 < T_H \leq 0.01 \text{ s} & \text{site classes A and B} \\ 1.0 + \left(\frac{50}{3}\right)(T_H - 0.01) & 0.01 \text{ s} < T_H \leq 0.1 \text{ s} \\ 2.5 & 0.1 \text{ s} < T_H \leq 0.4 \text{ s} \\ \left(\frac{1}{T_H}\right) & 0.4 \text{ s} < T_H \leq 6.0 \text{ s} \\ \left(\frac{6}{T_H^2}\right) & 6.0 \text{ s} < T_H \leq 10.0 \text{ s} \end{cases} \\ \\ \begin{cases} 1.0 & 0 < T_H \leq 0.01 \text{ s} & \text{site class C} \\ 1.0 + \left(\frac{50}{3}\right)(T_H - 0.01) & 0.01 \text{ s} < T_H \leq 0.1 \text{ s} \\ 2.5 & 0.1 \text{ s} < T_H \leq 0.6 \text{ s} \\ \left(\frac{1.5}{T_H}\right) & 0.6 \text{ s} < T_H \leq 6.0 \text{ s} \\ \left(\frac{9}{T_H^2}\right) & 6.0 \text{ s} < T_H \leq 10.0 \text{ s} \end{cases} \\ \\ \begin{cases} 1.0 & 0 < T_H \leq 0.01 \text{ s} & \text{site class D} \\ 1.0 + \left(\frac{50}{3}\right)(T_H - 0.01) & 0.01 \text{ s} < T_H \leq 0.1 \text{ s} \\ 2.5 & 0.10 \text{ s} < T_H \leq 0.8 \text{ s} \\ \left(\frac{2.0}{T_H}\right) & 0.8 \text{ s} < T_H \leq 6.0 \text{ s} \\ \left(\frac{12}{T_H^2}\right) & 6.0 \text{ s} < T_H \leq 10.0 \text{ s} \end{cases} \end{cases}$$

$$A_{NV,5\%}(T_V) = \delta_V(T_V) \begin{cases} \begin{cases} 1.0 & 0 < T_V \leq 0.01 \text{ s} & \text{site classes A and B} \\ 1.0 + \left(\frac{50}{3}\right)(T_V - 0.01) & 0.01 \text{ s} < T_V \leq 0.1 \text{ s} \\ 2.5 & 0.1 \text{ s} < T_V \leq 0.4 \text{ s} \\ \left(\frac{1}{T_V}\right) & 0.4 \text{ s} < T_V \leq 6.0 \text{ s} \\ \left(\frac{6}{T_V^2}\right) & 6.0 \text{ s} < T_V \leq 10.0 \text{ s} \end{cases} \\ \\ \begin{cases} 1.0 & 0 < T_V \leq 0.01 \text{ s} & \text{site class C} \\ 1.0 + \left(\frac{50}{3}\right)(T_V - 0.01) & 0.01 \text{ s} < T_V \leq 0.1 \text{ s} \\ 2.5 & 0.1 \text{ s} < T_V \leq 0.6 \text{ s} \\ \left(\frac{1.5}{T_V}\right) & 0.6 \text{ s} < T_V \leq 6.0 \text{ s} \\ \left(\frac{9}{T_V^2}\right) & 6.0 \text{ s} < T_V \leq 10.0 \text{ s} \end{cases} \\ \\ \begin{cases} 1.0 & 0 < T_V \leq 0.01 \text{ s} & \text{site class D} \\ 1.0 + \left(\frac{50}{3}\right)(T_V - 0.01) & 0.01 \text{ s} < T_V \leq 0.1 \text{ s} \\ 2.5 & 0.1 \text{ s} < T_V \leq 0.8 \text{ s} \\ \left(\frac{2.0}{T_V}\right) & 0.8 \text{ s} < T_V \leq 6.0 \text{ s} \\ \left(\frac{12}{T_V^2}\right) & 6.0 \text{ s} < T_V \leq 10.0 \text{ s} \end{cases} \end{cases}$$

where $\delta_V(T_V)$ is as per **6.2.3.2(a)(1)**.

Corresponding to the viscous damping ratio ξ of 5 percent of critical damping, the normalised horizontal and vertical PSV and the normalised horizontal and vertical SD for the portion of the structure above ground can be estimated as:

$$V_{NH,5\%}(T_H) = \left(\frac{T_H}{2\pi}\right) A_{NH,5\%}(T_H)$$

$$V_{NV,5\%}(T_V) = \left(\frac{T_V}{2\pi}\right) A_{NV,5\%}(T_V)$$

$$D_{NH,5\%}(T_H) = \left(\frac{T_H}{2\pi}\right)^2 A_{NH,5\%}(T_H)$$

$$D_{NV,5\%}(T_V) = \left(\frac{T_V}{2\pi}\right)^2 A_{NV,5\%}(T_V)$$

b) *Below ground*

- 1) For the structure or the portions of the structure buried below ground by the *drilled-in-place* construction method, the normalised horizontal and vertical below ground PSA $A_{NHB,5\%}(T_H)$ and $A_{NVB,5\%}(T_V)$ shall be taken as:

$$A_{NHB,5\%}(T_H) = \begin{cases} \left(1 - \frac{h_e}{60}\right) A_{NH,5\%}(T_H) & 0 < h_e \leq 30 \text{ m} \\ 0.5 A_{NH,5\%}(T_H) & 30 \text{ m} < h_e \end{cases}$$

$$A_{NVB,5\%}(T_V) = \begin{cases} \left(1 - \frac{h_e}{60}\right) A_{NV,5\%}(T_V) & 0 < h_e \leq 30 \text{ m} \\ 0.5 A_{NV,5\%}(T_V) & 30 \text{ m} < h_e \end{cases}$$

where

- $A_{NH,5\%}(T_H)$ = normalised horizontal PSA estimated as per **6.2.3.2(a)**;
- $A_{NV,5\%}(T_V)$ = normalised vertical PSA estimated as per **6.2.3.2(a)**; and
- h_e = depth (m) of embedment of the structure from the ground surface.

Also, even in the drilled-in-place method of construction, this reduction can be considered in the earthquake analysis of such structures only by the equivalent static method and not by the response spectrum method. Further, this reduction is not applicable for the case of cut-and-fill method of construction below the ground.

- 2) These reduced $A_{NHB,5\%}(T_H)$ and $A_{NVB,5\%}(T_V)$ shall be used only for estimating inertia effects due to masses buried at the corresponding levels below the ground; the inertia effects for the above-ground portion of the building shall be estimated based on the unreduced $A_{NH,5\%}(T_H)$ and $A_{NV,5\%}(T_V)$;
- 3) In the estimation of inertia forces below the ground surface, a part of the mass of the backfill material shall be considered, if the backfill is a granular material. The fraction of the mass (if any) shall be determined as specified in the respective part of IS 1893 depending on the type of the structure, and based on the geometry of the structure and the properties of the backfill material; and
- 4) Corresponding to the viscous damping ratio ξ of 5 percent of critical damping, the normalised horizontal and vertical below-ground PSV and the normalised horizontal and vertical below-ground SD for the portion of the structure below ground shall be estimated as:

$$V_{NHB,5\%}(T_H) = \left(\frac{T_H}{2\pi}\right) A_{NHB,5\%}(T_H)$$

$$V_{NVB,5\%}(T_V) = \left(\frac{T_V}{2\pi}\right) A_{NVB,5\%}(T_V)$$

$$D_{\text{NHB},5\%}(T_H) = \left(\frac{T_H}{2\pi}\right)^2 A_{\text{NHB},5\%}(T_H)$$

$$D_{\text{NVB},5\%}(T_V) = \left(\frac{T_V}{2\pi}\right)^2 A_{\text{NVB},5\%}(T_V)$$

6.2.3.3 *Normalised elastic maximum horizontal and vertical PSA, PSV and SD for damping ratio other than 5 percent of critical damping*

- a) Unless stated otherwise, the damping to be used in estimating the design earthquake forces shall be taken as 5 percent. In exceptional cases, like sloshing modes in liquid-retaining structures, and or special components of industrial structures, values of damping other than 5 percent shall be considered as per IS 1893 (Part 2) and IS 1893 (Part 4), respectively;
- b) The normalised PSA, PSV and SD for horizontal and vertical ground shaking, corresponding to values of damping (ξ) other than 5 percent (up to 30 percent or less), for each site class, shall be taken as:

$$A_{\text{NH}}(T_H) = A_{\text{NH},5\%}(T_H) \delta_{\xi}(T_H)$$

$$A_{\text{NV}}(T_V) = A_{\text{NV},5\%}(T_V) \delta_{\xi}(T_V)$$

$$V_{\text{NH}}(T_H) = V_{\text{NH},5\%}(T_H) \delta_{\xi}(T_H)$$

$$V_{\text{NV}}(T_V) = V_{\text{NV},5\%}(T_V) \delta_{\xi}(T_V)$$

$$D_{\text{NH}}(T_H) = D_{\text{NH},5\%}(T_H) \delta_{\xi}(T_H)$$

$$D_{\text{NV}}(T_V) = D_{\text{NV},5\%}(T_V) \delta_{\xi}(T_V)$$

$$A_{\text{NHB}}(T_H) = A_{\text{NHB},5\%}(T_H) \delta_{\xi}(T_H)$$

$$A_{\text{NVB}}(T_V) = A_{\text{NVB},5\%}(T_V) \delta_{\xi}(T_V)$$

$$V_{\text{NHB}}(T_H) = V_{\text{NHB},5\%}(T_H) \delta_{\xi}(T_H)$$

$$V_{\text{NVB}}(T_V) = V_{\text{NVB},5\%}(T_V) \delta_{\xi}(T_V)$$

$$D_{\text{NHB}}(T_H) = D_{\text{NHB},5\%}(T_H) \delta_{\xi}(T_H)$$

$$D_{\text{NVB}}(T_V) = D_{\text{NVB},5\%}(T_V) \delta_{\xi}(T_V)$$

where

T_H = horizontal natural period (s); and

T_V = fundamental vertical natural period (s) of the structure, which shall be taken as 0.4 s in equivalent static method, and obtained by modal analysis in response spectrum method,

$$\delta_{\xi}(T_H) = \begin{cases} 1 & 0 < T_H \leq 0.01 \text{ s} \\ 1 + \left(\frac{T_H - 0.01}{0.09}\right) (\eta_{\text{max},\xi} - 1) & 0.01 \text{ s} < T_H \leq 0.10 \text{ s} \\ \eta_{\text{max},\xi} & 0.10 \text{ s} < T_H \leq T_{\text{AV}} \\ \eta_{\text{max},\xi} - \left(\frac{T_H - T_{\text{AV}}}{6 - T_{\text{AV}}}\right) (\eta_{\text{max},\xi} - 1) & T_{\text{AV}} < T_H \leq 6.0 \text{ s} \\ 1 & T_H > 6.0 \text{ s} \end{cases}$$

$$\delta_{\xi}(T_V) = \begin{cases} 1 & 0 < T_V \leq 0.01 \text{ s} \\ 1 + \left(\frac{T_V - 0.01}{0.09}\right) (\eta_{\max, \xi} - 1) & 0.01 \text{ s} < T_V \leq 0.10 \text{ s} \\ \eta_{\max, \xi} & 0.10 \text{ s} < T_V \leq T_{AV} \\ \eta_{\max, \xi} - \left(\frac{T_V - T_{AV}}{6 - T_{AV}}\right) (\eta_{\max, \xi} - 1) & T_{AV} < T_V \leq 6.0 \text{ s} \\ 1 & T_V > 6.0 \text{ s} \end{cases}$$

in which

T_{AV} = corner period demarcating the junction of acceleration-sensitive and velocity-sensitive regions (see Fig. 2):

$$= \begin{cases} 0.4 & \text{Site Classes A and B} \\ 0.6 & \text{Site Class C} \\ 0.8 & \text{Site Class D} \end{cases}, \text{ and}$$

$$\eta_{\max, \xi} = \begin{cases} 3.2 & \xi = 0 \\ 3.2 - 268 \xi & 0 < \xi \leq 0.005 \\ \left(\frac{7}{2 + 100\xi}\right)^{0.6} & 0.005 < \xi \leq 0.05 \\ \left(\frac{10}{5 + 100\xi}\right)^{0.5} & 0.05 < \xi \leq 0.30 \end{cases}$$

- c) No expression is provided for $\eta_{\max, \xi}$ for values of ξ more than 30 percent of critical damping. When such situations arise, $\eta_{\max, \xi}$ shall be taken as its value corresponding to $\xi = 0.30$.

6.2.3.4 Elastic maximum horizontal and vertical PSAs, PSVs and SDs

The elastic maximum horizontal and vertical PSAs, PSVs and SDs corresponding to the chosen damping ratio shall be estimated as:

$$A_H(T_H) = ZI A_{NH}(T_H)$$

$$A_V(T_V) = ZI A_{NV}(T_V)$$

$$V_H(T_H) = ZI V_{NH}(T_H)$$

$$V_V(T_V) = ZI V_{NV}(T_V)$$

$$D_H(T_H) = ZI D_{NH}(T_H)$$

$$D_V(T_V) = ZI D_{NV}(T_V)$$

$$A_{HB}(T_H) = ZI A_{NHB}(T_H)$$

$$A_{VB}(T_V) = ZI A_{NVB}(T_V)$$

$$V_{HB,5\%}(T_H) = ZI V_{NHB}(T_H)$$

$$V_{VB,5\%}(T_V) = ZI V_{NVB}(T_V)$$

$$D_{HB,5\%}(T_H) = ZI D_{NHB}(T_H)$$

$$D_{VB,5\%}(T_V) = ZI D_{NVB}(T_V)$$

where

Z = earthquake zone factor as per 6.2.2.2 for the category of structure in the earthquake zone of the project site (as per Table 2) corresponding to the return period T_R specified in Table 1 or Table 2; and

I = importance factor as per 8.2.2.

6.3 Site-Specific Earthquake Hazard

The design earthquake horizontal force ($V_{BD,HSS}$) at the base of the structure and the design earthquake vertical force ($V_{BD,VSS}$) at the base of the structure considering site-specific PSA spectrum shall be estimated as:

$$V_{BD,H} = A_{HD}W = \frac{Z I A_{HSS}(T_H)}{R} \left(\frac{W}{g}\right)$$
$$V_{BD,V} = A_{VD}W = Z I A_{VSS}(T_V) \left(\frac{W}{g}\right)$$

where

- A_{HD} = design horizontal acceleration coefficient of the structure;
- A_{VD} = design vertical acceleration coefficient of the structure;
- W = seismic weight of the structure taken as per **8.2.1**;
- Z = earthquake zone factor taken as per **6.2.2.2**;
- I = importance factor taken as per **8.2.2**;
- A_{HSS} = horizontal spectral acceleration of the structure taken as per **6.3.3**;
- A_{VSS} = vertical spectral acceleration of the structure taken as per **6.3.3**;
- R = elastic force reduction factor taken as per **8.2.3**; and
- g = acceleration due to gravity.

6.3.1 Essential Requirement for Site-Specific Earthquake Hazard Assessment

Site-specific earthquake hazard assessment can be developed specifically to perform earthquake-resistant design of that structures at a project site. Site-specific earthquake hazard assessment shall be performed at project sites when structures rest on:

- Site class A, B, C or D, and design return period is 2 475 years or more; and
- Site class E.

6.3.2 Lower Bound of Site-Specific Spectrum

6.3.2.1 When the elastic acceleration spectrum is developed specifically to perform earthquake-resistant design of critical and special structures, the effects of the site-specific spectrum can be less than those arising out of the elastic acceleration spectrum

specified in this standard, provided the following are in place:

- A technical committee (constituted by the owner of the structure) consisting of subject specialists each having competence in each of the domains relevant to earthquake hazard assessment (including earthquake geology, earthquake geophysics, seismology, paleo-seismology, seismotectonics, earthquake geotechnical engineering, and earthquake structural engineering) to guide and critique the processes of site-specific earthquake hazard assessment; and
- The statutory authority of the government with jurisdiction over the site of the project has due systems and processes in place to examine the recommendations of the said technical committee, and take considered decisions.

In the absence of the above rigour, the effects of the site-specific spectrum shall not be less than those arising out of the design elastic acceleration spectrum specified in this standard.

6.3.2.2 For site class A, B, C and D, even if the two conditions in **6.3.2.1** are satisfied, the normalised horizontal PSA estimated by site-specific earthquake hazard assessment shall not be less than:

- two-thirds of the normalised design horizontal PSA in critical structures; and
- the normalised design horizontal PSA in special structures,

corresponding to the natural period as specified in this standard for the site class considered.

6.3.2.3 When the site class is E,

- the ground shall be strengthened to improve its stiffness and strength;
- if the strengthening of the ground (as specified above) places the site in site class D or better, based on the improved weighted average of V_S , then the need for site-specific earthquake hazard assessment shall be governed by **6.3.1**; and
- if the strengthening of the ground (as specified above) does not place the site in site class D or better, based on the improved weighted average of V_S , then the normalised horizontal PSA estimated by site-specific earthquake hazard assessment shall not be less than the minimum of 2.5 and 1.25 times the normalised design horizontal PSA at the corresponding natural period as specified in this standard for site class D.

6.3.3 Procedure for Site-Specific Earthquake Hazard Assessment

6.3.3.1 Principles of probabilistic earthquake hazard analysis (PEHA) shall be employed to obtain the site-specific earthquake hazard at the project site. In doing so, the following shall be ensured:

- The uniform hazard is derived as the normalised PSA spectrum;
- The return period adopted is consistent with that specified in **6.2.2.2** for the category of structure in focus;
- PSA, PSV, and SD spectra is derived corresponding to the damping ratio of 5 percent of critical damping;
- For other values of damping, the spectrum is obtained by multiplying with $\delta_{\xi}(T)$ defined in **6.2.3.3**; and
- When the earthquake hazard estimated based on PEHA is less than that estimated based on DEHA, then the latter is considered.

6.3.3.2 The elastic maximum horizontal and vertical site-specific PSA, PSV and SD corresponding to damping ratio of 5 percent of critical damping shall be estimated as:

$$\begin{aligned}
 A_{HSS,5\%}(T_H) &= I A_{SS,H,5\%}(T_H) \\
 A_{VSS,5\%}(T_V) &= I A_{SS,V,5\%}(T_V) \\
 V_{HSS,5\%}(T_H) &= \left(\frac{T_H}{2\pi}\right) A_{HSS,5\%}(T_H) \\
 V_{VSS,5\%}(T_V) &= \left(\frac{T_V}{2\pi}\right) A_{VSS,5\%}(T_V) \\
 D_{HSS,5\%}(T_H) &= \left(\frac{T_H}{2\pi}\right)^2 A_{HSS,5\%}(T_H) \\
 D_{VSS,5\%}(T_V) &= \left(\frac{T_V}{2\pi}\right)^2 A_{VSS,5\%}(T_V)
 \end{aligned}$$

where

- I = importance factor as per **8.2.2**;
- $A_{SS,H,5\%}(T_V)$ = horizontal site-specific PSA (in m/s^2) derived as per PEHA consistent with the procedure specified for damping ratio of 0.05; and
- $A_{SS,V,5\%}(T_V)$ = vertical site-specific PSA (in m/s^2) derived as per PEHA consistent with the procedure specified for damping ratio of 0.05.

6.3.3.3 The elastic maximum horizontal and vertical site-specific below ground PSA, PSV and SD corresponding to damping ratio of 5 percent of critical damping shall be estimated as:

$$A_{SS,HB,5\%}(T_H) = \begin{cases} \left(1 - \frac{h_e}{60}\right) A_{SS,H,5\%}(T_H) & 0 < h_e \leq 30 \text{ m} \\ 0.5 A_{SS,H,5\%}(T_H) & 30 \text{ m} < h_e \end{cases}$$

$$A_{SS,VB,5\%}(T_V) = \begin{cases} \left(1 - \frac{h_e}{60}\right) A_{SS,V,5\%}(T_V) & 0 < h_e \leq 30 \text{ m} \\ 0.5 A_{SS,V,5\%}(T_V) & 30 \text{ m} < h_e \end{cases}$$

$$\begin{aligned}
 A_{HSSB,5\%}(T_H) &= I A_{SS,HB,5\%}(T_H) \\
 A_{VSSB,5\%}(T_V) &= I A_{SS,VB,5\%}(T_V) \\
 V_{HSSB,5\%}(T_H) &= \left(\frac{T_H}{2\pi}\right) A_{HSSB,5\%}(T_H) \\
 V_{VSSB,5\%}(T_V) &= \left(\frac{T_V}{2\pi}\right) A_{VSSB,5\%}(T_V) \\
 D_{HSSB,5\%}(T_H) &= \left(\frac{T_H}{2\pi}\right)^2 A_{HSSB,5\%}(T_H) \\
 D_{VSSB,5\%}(T_V) &= \left(\frac{T_V}{2\pi}\right)^2 A_{VSSB,5\%}(T_V)
 \end{aligned}$$

where

$A_{SS,HB}(T_H)$ = horizontal site-specific below ground PSA (in m/s^2) derived as per PEHA consistent with the procedure specified above for the chosen damping ratio; and

$A_{SS,VB}(T_V)$ = vertical site-specific below ground PSA (in m/s^2) derived as per PEHA consistent with the procedure specified above for the chosen damping ratio.

6.3.3.4 The spectra mentioned in **6.3.3.3** corresponding to damping ratio other than 5 percent shall be estimated as:

$$A_{HSS}(T_H) = I A_{SS,H,5\%}(T_H) \delta_\xi(T_H)$$

$$A_{VSS}(T_V) = I A_{SS,V,5\%}(T_V) \delta_\xi(T_V)$$

$$V_{HSS}(T_H) = \left(\frac{T_H}{2\pi}\right) A_{HSS}(T_H)$$

$$V_{VSS}(T_V) = \left(\frac{T_V}{2\pi}\right) A_{VSS}(T_V)$$

$$D_{HSS}(T_H) = \left(\frac{T_H}{2\pi}\right)^2 A_{HSS}(T_H)$$

$$D_{VSS}(T_V) = \left(\frac{T_V}{2\pi}\right)^2 A_{VSS}(T_V)$$

$$A_{HSSB}(T_H) = \frac{I A_{SS,HB,5\%}(T_H) \delta_\xi(T_H)}{g}$$

$$A_{VSSB}(T_H) = \frac{I A_{SS,VB,5\%}(T_V) \delta_\xi(T_V)}{g}$$

$$V_{HSSB}(T_H) = \left(\frac{T_H}{2\pi}\right) A_{HSSB}(T_H)$$

$$V_{VSSB}(T_V) = \left(\frac{T_V}{2\pi}\right) A_{VSSB}(T_V)$$

$$D_{HSSB}(T_H) = \left(\frac{T_H}{2\pi}\right)^2 A_{HSSB}(T_H)$$

$$D_{VSSB}(T_V) = \left(\frac{T_V}{2\pi}\right)^2 A_{VSSB}(T_V)$$

where $\delta_\xi(T_H)$ and $\delta_\xi(T_V)$ shall be taken as specified in **6.2.3.3**.

7 DESIGN CRITERIA

A structure is said to be earthquake-resistant, if it possesses the attributes stated hereunder.

7.1 Structural Configuration

7.1.1 The structural system of a structure possesses a simple structural configuration that demonstrates direct, uninterrupted, and redundant load paths from any point on the structure to the foundations, and with the following features:

- Its overall geometry is convex (offering direct load paths for the inertia forces induced in them during earthquake shaking to reach the underlying soil stratum or soil strata), and elements are prismatic, to the extent possible;
- It resists effects of earthquake ground shaking expected at the site without inducing any local damage in its members, which jeopardises its structural safety;
- Its mass, stiffness and strength are distributed uniformly along its plan and elevation, with no abrupt changes; and
- It uses architectural elements and utilities minimally.

7.1.2 The quantitative requirements of structural configuration are complied with as specified in the respective part of IS 1893 depending on the type of the structure.

7.2 Initial Lateral Stiffness

A structure possesses at least the initial lateral stiffness specified in the respective part of IS 1893 depending on the type of the structure.

7.3 Lateral Strength

A structure possesses at least the overall lateral strength specified in the respective part of IS 1893 depending on the type of the structure.

7.4 Ductility

7.4.1 A structure in which damage is admissible possesses the ability to oscillate back and forth with damage but without collapse under the effects of earthquake shaking; this ability is called ductility. For the structure to possess ductility, at least its critical members possess ductility. In turn, the critical sections of the critical members possess ductility. And therefore, the materials used in the critical section shall also possess ductility.

7.4.2 No quantitative requirement is specified for ductility. But, the members and hence the structure are deemed to satisfy the requirements of ductility if the provisions of ductile design and detailing specified in IS 13920 (Part 1) and the respective part of IS 13920 depending on the type of structure are complied with.

7.5 Relative Displacement Capability

7.5.1 At all seismic joints in the structures, the relative movements between the adjoining parts of the structure shall be accommodated within the structure without any undesirable effect of either pounding or extension of any architectural element or utility passing from one part of the structure to the other across this joint.

7.5.2 The quantitative requirements of relative displacement capability shall be taken as specified in the respective part of IS 1893 depending on the type of the structure.

7.6 Deformability

A structure shall possess at least the lateral deformability specified in the respective part of IS 1893 depending on the type of the structure.

7.7 Collapse Mechanism

The design and detailing of members, joints and connections shall be such that the predetermined desirable lateral collapse mechanism is achieved during expected strong earthquake ground shaking. The virtue of predetermined desirable collapse mechanism shall be satisfied together by the structure, the devices, and the foundations.

7.8 Energy Dissipation Mechanism

A structure shall possess a large inelastic energy absorption capacity associated with a predetermined desirable collapse mechanism under the action of earthquake, along the load path up to the foundations. When structural elements are not permitted to sustain any inelastic action, the energy absorption shall be ensured to occur in the special devices meant to absorb the same (for example, base isolators and energy dissipation devices).

8 EARTHQUAKE DEMAND

8.1 Assumptions

The following assumptions shall be made in the earthquake-resistant design of structures:

- a) Design earthquake shaking is unlikely to occur simultaneously with design wind,

design flood, or design sea waves (including those owing to tsunamis). Hence, design earthquake loads specified in this standard are not combined with any of design wind, design flood or design wave loads, even though a lower level of the design wind, the design flood and the design wave loads may be combined in the design of limited structures (like bridges);

- b) The elastic modulus of materials, when required, shall be taken as those given in IS 456, IS 800, IS 1343, IS 1905, unless more definite values are available for use in dynamic condition or other values are suggested by IS 1893 (Part 2) to (Part 12) for different structures; and
- c) Resonance of the type as visualized under steady-state sinusoidal excitations will not occur, as it would need time to build up such amplitudes, except when resonance-like conditions occur when earthquake waves at the bedrock are amplified by the local soil strata such that the dominant natural period of earthquake ground shaking is close to that of the structures resting on them.

8.2 Design Earthquake Forces

8.2.1 Seismic Weight

The seismic weight (W) of a structure shall be taken as its full dead load (including superimposed dead load) plus an appropriate amount of imposed load, as specified in the respective part of IS 1893 depending on the type of the structure.

Values of imposed load shall be taken as specified in the respective part of IS 1893 depending on the type of the structure.

8.2.2 Importance Factor

The importance factor (I) to be used in the estimation of design acceleration coefficient of a structure shall be taken as specified in the respective part of IS 1893 depending on the type of the structure.

8.2.3 Elastic Force Reduction Factor

The elastic force reduction factor (R) to be used in the estimation of design acceleration coefficient of a structure shall be taken as specified in the respective part of IS 1893 depending on the type of the structure.

8.2.4 Design Earthquake Forces

The design horizontal and vertical earthquake forces EL for the design shall be estimated as below:

- a) EL shall be estimated along horizontal and vertical directions using the corresponding acceleration values specified in 6.2 or 6.3, corresponding to the return period T_R specified in Table 1 for design, as given below:
 - 1) First, the elastic maximum force shall be estimated by multiplying the elastic maximum PSA (specified in 6.2 or 6.3) with the seismic weight (specified in 8.2.1); and
 - 2) Then:
 - i) the horizontal EL shall be estimated by dividing the elastic maximum force by elastic force reduction factor R taken as those specified in the respective part of IS 1893 depending on the type of the structure, if damage is permitted in the structure, and 1.0, if damage is not permitted in the structure (and its components thereof); and
 - ii) the vertical EL shall be estimated taken as the vertical elastic maximum force estimated in 8.2.4(a)(1).
- b) The method of estimating design earthquake horizontal and vertical forces EL for design differs for different structure, and shall be estimated as per the respective part of IS 1893 depending on the type of the structure.

8.2.4.1 Minimum design earthquake forces

- a) The design earthquake forces specified in IS 1893 (Part 1) along with the respective part of IS 1893 depending on the type of the structure, are the minimum forces that the structures shall be designed for. The designer or owner can consider values of design earthquake forces for design higher than those specified herein. Also, structures designed with such higher requirements shall also comply with the requirements applicable as per the respective part of IS 1893 and IS 13920; and
- b) In any earthquake zone, steel towers, coastal structures and tunnels governed by IS 1893 (Part 1) for which the provisions

are under development, shall be designed for a design horizontal earthquake force not less than $0.015 W$, where W is the seismic weight of the structure.

8.3 Earthquake Analysis

Structures shall be analysed for estimating the effects of design earthquake shaking (namely the stress resultants and deformations) estimated as per this clause.

8.3.1 Analytical Model

A three-dimensional mathematical model shall be used in the structural analysis of all critical and special structures, and of irregular important and normal structures; it is recommended to be used in the structural analysis of important and normal structures. Such models shall reflect the aspects specified hereunder.

8.3.1.1 Geometry

The geometry of the whole structure and of its elements shall be represented accurately. The model shall represent adequately the structural configuration, especially when structures have unusual structural configurations with irregularities and when dynamic analysis is required to be performed.

8.3.1.2 Material

Material properties of:

- a) the structural elements, namely the modulus of elasticity E and the Poisson's ratio ν ; and
- b) the soil layers underneath the foundation, namely the shear modulus G , the Poisson's ratio ν_s , and the modulus of subgrade reaction K , shall reflect the range of response expected during the earthquake shaking in the structural elements and soil layers, respectively.

8.3.1.3 Mass and stiffness

The analytical model of structures shall capture the three-dimensional distribution of stiffness and mass of the structure. Also:

- a) the effects of flexural and shear deformations shall be considered in the estimation of stiffnesses, especially of vertical elements; and
- b) the axial, flexural, shearing and torsional response-related stiffness properties, shall be consistent with the structural behaviour.

8.3.1.4 Boundary conditions

Boundary conditions at the support points of the structure, shall reflect the actual conditions at the site. No artificial hinges shall be introduced in the model in concrete structures that are cast monolithically.

8.3.1.5 Soil flexibility

- a) Flexibility of the soil stratum or strata on which the structure is rested (as specified in **9.1.2**), considering appropriately the level of water table, shall be addressed in one of the following ways:
 - 1) Considering just the flexibility of the soil adjoining the foundation structural elements, in the form of flexible soil translational and/or rotational springs (as appropriate), when performing the linear equivalent static analysis, where inertial effects are not considered explicitly; and
 - 2) Considering all aspects of soil-structure interaction (including the flexibility of the soil and inertia of the soil), when required to perform the dynamic analysis with such effects considered for the structure being designed or assessed.
- b) The modulus of subgrade reaction K of soils shall be considered to vary over the range $0.5 K$ to $1.5 K$, where K is estimated from field tests. Structural analysis shall be performed using a 3D structural model with subgrade modulus varied as specified above, and the structure shall be designed for adequacy to resist the overall structural displacements, structural deformations and member strengths induced in it.

8.3.1.6 Shear deformations

The effect of shear deformations shall be considered in the stiffness matrices of structures.

8.3.2 Modal Analysis

Modal analysis shall be performed using the mass and initial stiffness matrices of the structure, and the dynamic characteristics (namely natural periods of the modes and the associated mode shapes) shall be extracted.

8.3.2.1 Natural period

- a) The natural periods of the structure shall be extracted from modal analysis;

- b) The fundamental natural period to be used in the estimation of the design lateral force in the equivalent static method of earthquake analysis (as per **8.3.3.1**) shall be taken as per:

- 1) the expression provided for the approximate fundamental natural period given in IS 1893 (Part 5) in the design of buildings; and
- 2) the modal analysis in the design of all other structures.

8.3.2.2 Mode shapes

The mode shapes of the structure associated with each natural period shall be such that:

- a) the fundamental lateral translational modes along the principal plan directions are precede the fundamental torsional mode; and
- b) the first three lateral translational modes along a principal plan direction together account for a substantial share of the total translational mass as per **8.3.3.2(d)**.

8.3.3 Methods of Earthquake Analysis

The method of analysis shall be linear for the earthquake-resistant design of structures, which can be performed by the following methods:

- a) Static analysis by the equivalent static method;
- b) Dynamic analysis by the response spectrum method; and
- c) Dynamic analysis by the response history method.

8.3.3.1 Equivalent static method

This method shall be used for analysis of structures whose dominant response under earthquake shaking along each plan direction is governed by the response of their first translational mode of oscillation with 80 percent or more mass participation. The equivalent static method shall be performed as specified hereunder:

- a) Prepare the analytical model as per **8.3.1**;
- b) Apply DL as per IS 875 (Part 1);
- c) Apply IL as per IS 875 (Part 2);
- d) Apply EL as given below:
 - 1) estimate the design earthquake base force V_{BD} on a structure as per **6.2** or **6.3**; and

- 2) distribute V_{BD} along the elevation of the structure as per the respective part of IS 1893 depending on the type of the structure.
 - f) Combine the effects of EL with those of DL and IL as per the load combinations given **8.4**.
 - g) Extract the responses, namely:
 - 1) the stress resultants in the members; and
 - 2) the deformations in members and in the structure.
 - h) Use these combined demands when designing the structure as per IS 13920 (Part 1) and respective part of IS 13920 depending on the type of the structure.
- e) Perform linear static analysis of the structure separately under DL, IL and EL.
 - i) design earthquake base force $\overline{V_{BD}}$ of the structure;
 - ii) design stress resultants, that is, axial force, shear force, bending moment and torsional moment induced in structural elements of the structure; and
 - iii) design deformations, that is, translations and rotations, at nodes of the structure or in structural elements of the structure, shall be estimated as a statistical combination of those of the considered natural modes of oscillation, as per complete quadratic combination (CQC) method given below:

8.3.3.2 Response spectrum method

This method shall be used for analysis of structures to better capture irregular distribution of mass or stiffness. This method shall consider the responses of select individual natural modes of oscillation of the structure, and combine them. The response spectrum method shall be performed as specified hereunder:

- a) Prepare the analytical model as per **8.3.1**;
- b) Apply DL as per IS 875 (Part 1);
- c) Apply IL as per IS 875 (Part 2);
- d) Perform modal analysis, and obtain the natural periods T_k and mode shapes $\{\phi\}_k$ for $k = 1, 2, \dots, N_m$, where the number of modes N_m to be used in the analysis for earthquake shaking along a considered direction shall be such that the sum of modal masses of the considered modes is at least 90 percent of the total seismic mass;
- e) Estimate EL of the structure as given below:

1) Responses in each mode

The design earthquake effect attracted by each mode of oscillation considered is estimated using its corresponding natural period, and the design acceleration spectrum specified in **6.2** or the site-specific design acceleration spectrum mentioned in **6.3**. Additional requirements may be considered as described in the respective part of IS 1893 depending on the type of the structure.

2) Combination of responses in different modes

The peak responses due to the modes considered, namely:

$$\lambda = \sqrt{\sum_{i=1}^{N_m} \sum_{j=1}^{N_m} \lambda_i \rho_{ij} \lambda_j}$$

where

λ = estimate of net peak response;

N_m = number of modes considered;

λ_i = peak response (with sign) in mode i ;

ρ_{ij} = cross-modal correlation coefficient

$$= \frac{8\xi^2 (1 + \beta) \beta^{1.5}}{(1 - \beta^2)^2 + 4 \xi^2 \beta (1 + \beta)^2};$$

λ_j = peak response (with sign) in mode j ;

ξ = modal damping coefficient ratio which shall be taken as 0.05;

β = natural period ratio

$$= \frac{T_i}{T_j};$$

T_i = natural period of mode i ; and

T_j = natural period of mode j .

3) Missing mass correction

Missing mass correction shall be performed as specified hereunder, if the sum of masses of all the modes considered is less than 90 percent of the total mass of the structure. In such a case, the effects of the remaining mass shall be considered as specified hereunder;

The effect of natural modes not considered in **8.3.3.2(e)(2)** shall be addressed as specified hereunder:

- i) Obtain, at each degree of freedom, the sum of masses corresponding to that degree of freedom from the natural modes considered;
- ii) Subtract, at each degree of freedom, the sum of masses in (i) above from all modes considered from the total mass, and estimate at each degree of freedom, the missing mass M_{miss} ;
- iii) Estimate the design acceleration PSA $A_D(T_{co})$ corresponding to the cut-off natural period T_{co} , from the design acceleration spectrum specified in **6.2**, or the design acceleration site-specific spectrum mentioned in **6.3**. Here, T_{co} shall be taken as the natural period of the last mode considered;
- iv) Multiply at each degree of freedom i the missing mass M_{miss} estimated in (ii) above with the design acceleration PSA $A_D(T_{co})$ estimated in (iii) above, and estimate the missing design force $F_{D,\text{miss},i}$;
- v) Apply at each degree of freedom i the missing design forces $F_{D,\text{miss},i}$, and perform a separate linear structural analysis; and
- vi) Combine the responses (including the base shear of the structure) estimated in (v) above with those of the other natural modes whose natural periods are more than the cut-off natural period T_{co} , as per **8.3.3.2(e)(2)**, assuming the natural period of the missing mass to be T_{co} .

4) Adjust the design lateral force demand

The design earthquake base force $\overline{V_{BD}}$ obtained from **8.3.3.2(e)(2)** and **8.3.3.2(e)(3)** shall not be less than V_{BD} estimated by the equivalent static method in **8.3.3.1**. If $\overline{V_{BD}} < V_{BD}$, then the force responses estimated by the response spectrum method shall be amplified by the ratio $(V_{BD}/\overline{V_{BD}})$, but the deformation responses need not be.

- f) Perform linear static analysis of the structure separately under DL and IL;
- g) Combine the effects of EL estimated in **8.3.3.2(e)** with those of DL and IL estimated in **8.3.3.2(f)** as per the load combinations given **8.4**;
- h) Extract the responses, namely:
 - 1) the stress resultants in the members; and
 - 2) the deformations in members and in the structure:
 - i) Use these combined demands when designing the structure as per IS 13920 (Part 1) and the respective part of IS 13920 depending on the type of the structure.

8.3.3.3 Response history method

This method shall be used for analysis of structures to better capture earthquake hazard through recorded ground motions, irregular distribution of mass or stiffness, inertial amplification, and torsional amplification. It shall consider the responses of the structure as a function of time under each of the ground motions considered. The response history method shall be performed as specified hereunder:

- a) Prepare the analytical model as per **8.3.1**. In addition, damping shall be considered in the form of rayleigh damping, whose coefficients shall be calculated as specified hereunder:
 - 1) For ground shaking considered along one horizontal plan direction at a time (namely X-direction; Y-direction; X-direction and Z-direction; Y-direction and Z-direction, as admissible as per **8.4.3**), 5 percent of critical damping shall be provided to the natural periods of the first two translational modes along the principal plan direction considered; and

- 2) For ground shaking considered along two horizontal plan directions together (namely X- direction and Y-direction; X-direction, Y-direction and Z-direction, as admissible as per **8.4.3**), 5 percent of critical damping shall be provided to the largest and smallest natural periods of T_{X1} , T_{X2} , T_{Y1} and T_{Y2} , where T_{X1} and T_{X2} correspond to the first two translational modes along X-direction, and T_{Y1} and T_{Y2} correspond to the first two translational modes along Y-direction.
- b) Apply DL as per IS 875 (Part 1);
 - c) Apply IL as per IS 875 (Part 2);
 - d) Apply EL by considering the suite of recorded ground motions appropriate to the site of the structure, namely far-fault and near-fault sites, as specified hereunder:

1) *Ground motion*

- i) A suite of scaled ground motions for the site class of the structure given in Annex E (each consisting of three components of ground motions at the station where they are recorded) consisting of:
 - a) 30 far-fault recorded ground motions in Zones II, III and IV; and
 - b) 60 scaled recorded ground motions in Zones V and VI, of which:
 - 1) 30 are scaled far-fault recorded ground motions; and
 - 2) 30 are scaled near-fault recorded ground motions.

All of the said recorded ground motions shall be used, and not just a few of them.

- ii) The above recorded ground motions are pre-scaled to account for the earthquake zone factor Z only. These acceleration histories shall be multiplied by $(1/R)$ to account for the Elastic Force Reduction Factor R corresponding to the structural system.

2) *Base force for each recorded ground motion*

- i) Estimate the response for each recorded ground motion by time-marching integration of the linear governing matrix equation; and
- ii) Extract the maximum base shear $\overline{V_{BD}}$ during the entire duration of ground motion.

4) *Design lateral force for each recorded ground motion*

The design earthquake base force $\overline{V_{BD}}$ shall not be less than V_{BD} estimated by the equivalent static method as per **6.2** or **6.3**. If $\overline{V_{BD}} < V_{BD}$, then the force responses estimated by the response history method shall be amplified by the ratio $(V_{BD}/\overline{V_{BD}})$, but the deformation responses need not be.

5) *Design demand*

Extract the histories of all responses (namely deformations in the structure and members, and stress-resultants in members) for each recorded ground motion.

- i) the design deformation demands (displacements and rotations) on each member shall be the envelope maximum of the respective values; and
- ii) the design stress-resultant demands (axial force and bending moments) on each member shall be the envelope of the $P - M_1 - M_2$ trace; and
- iii) the design shear force demand on each member shall be the envelope maximum, obtained by the response history analyses of the structure subjected to the ground motions considered in **8.3.3.3(d)(1)**. Here, the effect of torsional moments, when considered in design, shall be taken as per the provisions of the basic design standards, namely IS 456, IS 800 and IS 1905.

- e) Perform linear static analysis of the structure separately under DL and IL.
- f) Combine the effects of EL estimated in **8.3.3.3(d)(5)** with those of DL and IL estimated in **8.3.3.3(e)** as per the load combinations given **8.4**.

- g) Extract the responses, namely
- 1) the stress resultants in the members; and
 - 2) the deformations in members and in the structure.
- h) Use these combined demands when designing the structure as per IS 13920 (Part 1) and respective part of IS 13920 depending on the type of the structure.

8.3.3.4 Applicability of methods

The applicability of the three methods given in 8.3.1 to 8.3.3 shall be taken as specified in the respective part of IS 1893 depending on the type of the structure.

8.4 Load Combinations

Structures shall be designed for the effects of design earthquake shaking (namely the stress resultants and deformations) estimated as per load combinations as specified hereunder.

8.4.1 Basic Load Combinations

The basic load combinations shall be considered as specified hereunder in the design of:

- a) structural elements (including structural elements of foundations) of concrete and steel structures by the limit state method:
 - 1) $1.2 DL + 1.2 IL \pm EL$;
 - 2) $1.5 DL \pm EL$; and
 - 3) $0.9 DL \pm EL$.
- b) structural elements of masonry structures by the working stress method:
 - 1) $1.1 DL + 1.1 IL \pm EL$;
 - 2) $1.1 DL \pm EL$; and
 - 3) $0.9 DL \pm EL$, and
- c) soil by the working stress method:
 - 1) $1.1 DL + 1.1 IL \pm EL$;
 - 2) $1.1 DL \pm EL$; and
 - 3) $0.9 DL \pm EL$.

where

DL = dead load as specified in IS 875 (Part 1);

IL = imposed load as specified in IS 875 (Part 2), without the reduction in imposed load permitted in 8.2.1.1; and

EL = effect of design earthquake forces to be considered for design (estimated as per 8.3.3) applied on the structure, with the reduction in imposed load

permitted in 8.2.1.1.

8.4.2 Additional Load Combinations

Additional load combinations shall be considered as specified in respective part of IS 1893 depending on the type of the structure.

8.4.3 Multi-Directional Earthquake Shaking

When earthquake ground shaking is considered to act simultaneously along multiple directions, the same response quantity (say, bending moment in a bridge pier, or storey shear force in a building frame) due to different components of the ground motion shall be combined, as specified hereunder.

The design horizontal and vertical forces due to horizontal and vertical ground shakings shall be estimated as per 8.2.4.

8.4.3.1 One horizontal plan direction at a time

Effects of one-direction horizontal earthquake ground shaking can be considered in the design of structures, when the structural configuration is regular in plan and in elevation, that is, when lateral force resisting elements are oriented along two mutually orthogonal horizontal directions in plan (say X-direction and Y-direction) and do not cause any stiffness eccentricity in plan. In such cases, it is sufficient to design the structure for effects due to full design earthquake load in one horizontal plan direction considered at a time.

Thus, the load combinations specified in 8.4.1 shall be replaced with:

- a) structural elements (including structural elements of foundations) of concrete and steel structures by the limit state method:
 - 1) $1.2 DL + 1.2 IL \pm EL_X$;
 - 2) $1.2 DL + 1.2 IL \pm EL_Y$;
 - 3) $1.5 DL \pm EL_X$;
 - 4) $1.5 DL \pm EL_Y$;
 - 5) $0.9 DL \pm EL_X$; and
 - 6) $0.9 DL \pm EL_Y$.
- b) structural elements of masonry structures by the working stress method:
 - 1) $1.0 DL + 1.0 IL \pm EL_X$;
 - 2) $1.0 DL + 1.0 IL \pm EL_Y$;
 - 3) $1.0 DL \pm EL_X$;
 - 4) $1.0 DL \pm EL_Y$;
 - 5) $0.9 DL \pm EL_X$; and
 - 6) $0.9 DL \pm EL_Y$.
- c) soil by the working stress method:
 - 1) $1.0 DL + 1.0 IL \pm EL_X$;

- 2) $1.0 DL + 1.0 IL \pm EL_Y$;
- 3) $1.0 DL \pm EL_X$;
- 4) $1.0 DL \pm EL_Y$;
- 5) $0.9 DL \pm EL_X$; and
- 6) $0.9 DL \pm EL_Y$.

8.4.3.2 *Two mutually orthogonal plan directions together*

Effects of two-dimensional horizontal earthquake ground shaking shall be considered together in the design of structures, when the structural configuration is irregular in plan, that is, when lateral force resisting elements are not oriented along mutually orthogonal horizontal directions in plan. In such cases, the structure shall be designed for the effects due to full design earthquake load in one horizontal direction plus 30 percent of design earthquake load along the other horizontal direction.

Thus, the load combinations specified in **8.4.1** shall be replaced with:

- a) structural elements (including structural elements of foundations) of concrete and steel structures by the limit state method:
 - 1) $1.2 DL + 1.2 IL \pm (EL_X \pm 0.3 EL_Y)$;
 - 2) $1.2 DL + 1.2 IL \pm (0.3 EL_X \pm EL_Y)$;
 - 3) $1.5 DL \pm (EL_X \pm 0.3 EL_Y)$;
 - 4) $1.5 DL \pm (0.3 EL_X \pm EL_Y)$;
 - 5) $0.9 DL \pm (EL_X \pm 0.3 EL_Y)$; and
 - 6) $0.9 DL \pm (0.3 EL_X \pm EL_Y)$.
- b) structural elements of masonry structures by the working stress method:
 - 1) $1.0 DL + 1.0 IL \pm (EL_X \pm 0.3 EL_Y)$;
 - 2) $1.0 DL + 1.0 IL \pm (0.3 EL_X \pm EL_Y)$;
 - 3) $1.0 DL \pm (EL_X \pm 0.3 EL_Y)$;
 - 4) $1.0 DL \pm (0.3 EL_X \pm EL_Y)$;
 - 5) $0.9 DL \pm (EL_X \pm 0.3 EL_Y)$; and
 - 6) $0.9 DL \pm (0.3 EL_X \pm EL_Y)$.
- c) soil by the working stress method:
 - 1) $1.0 DL + 1.0 IL \pm (EL_X \pm 0.3 EL_Y)$;
 - 2) $1.0 DL + 1.0 IL \pm (0.3 EL_X \pm EL_Y)$;
 - 3) $1.0 DL \pm (EL_X \pm 0.3 EL_Y)$;
 - 4) $1.0 DL \pm (0.3 EL_X \pm EL_Y)$;
 - 5) $0.9 DL \pm (EL_X \pm 0.3 EL_Y)$; and
 - 6) $0.9 DL \pm (0.3 EL_X \pm EL_Y)$.

8.4.3.3 *Three mutually orthogonal directions together*

Effects of earthquake ground shaking along three mutually orthogonal directions (that is two plan

directions and vertical direction) shall be considered in the design of structures, when:

- a) The structure is in earthquake Zone V or Zone VI;
- b) The structure is in earthquake Zone III or Zone IV, and is categorized as an important, critical or special structure;
- c) Embankments, bridges, and dams are being checked for stability; or
- d) The components of buildings, embankments, bridges, and dams are being designed for strength, especially when:
 - 1) The structure is irregular in plan or in elevation;
 - 2) The structure is resting on site class C, D or E;
 - 3) The structure has long spans, which causes amplification of oscillations in flexible members (reflected as fundamental or early local modes of oscillation of the structure involving only such spans);
 - 4) The structure has large overhangs of structural members or sub-systems (reflected as fundamental or early local modes of oscillation of the structure involving only such overhangs); or
 - 5) The structure has prestressed member(s).

In such cases, the structure shall be designed for the effects due to full design earthquake load in one direction plus 30 percent of the design earthquake load along each of the other two mutually orthogonal directions.

And, the load combinations specified in **8.4.1** shall be replaced with:

- a) structural elements (including structural elements of foundations) of concrete and steel structures by the limit state method:
 - 1) $1.2 DL + 1.2 IL \pm (EL_X \pm 0.3 EL_Y \pm 0.3 EL_Z)$;
 - 2) $1.2 DL + 1.2 IL \pm (0.3 EL_X \pm EL_Y \pm 0.3 EL_Z)$;
 - 3) $1.2 DL + 1.2 IL \pm (0.3 EL_X \pm 0.3 EL_Y \pm EL_Z)$;
 - 4) $1.5 DL \pm (EL_X \pm 0.3 EL_Y \pm 0.3 EL_Z)$;
 - 5) $1.5 DL \pm (0.3 EL_X \pm EL_Y \pm 0.3 EL_Z)$;
 - 6) $1.5 DL \pm (0.3 EL_X \pm 0.3 EL_Y \pm EL_Z)$;
 - 7) $0.9 DL \pm (EL_X \pm 0.3 EL_Y \pm 0.3 EL_Z)$;

- 8) $0.9 DL \pm (0.3 EL_X \pm EL_Y \pm 0.3 EL_Z)$;
and
- 9) $0.9 DL \pm (0.3 EL_X \pm 0.3 EL_Y \pm EL_Z)$.
- b) structural elements of masonry structures by the working stress method:
- 1) $1.0 DL + 1.0 IL \pm (EL_X \pm 0.3 EL_Y \pm 0.3 EL_Z)$;
- 2) $1.0 DL + 1.0 IL \pm (0.3 EL_X \pm EL_Y \pm 0.3 EL_Z)$;
- 3) $1.0 DL + 1.0 IL \pm (0.3 EL_X \pm 0.3 EL_Y \pm EL_Z)$;
- 4) $1.0 DL \pm (EL_X \pm 0.3 EL_Y \pm 0.3 EL_Z)$;
- 5) $1.0 DL \pm (0.3 EL_X \pm EL_Y \pm 0.3 EL_Z)$;
- 6) $1.0 DL \pm (0.3 EL_X \pm 0.3 EL_Y \pm EL_Z)$;
- 7) $0.9 DL \pm (EL_X \pm 0.3 EL_Y \pm 0.3 EL_Z)$;
- 8) $0.9 DL \pm (0.3 EL_X \pm EL_Y \pm 0.3 EL_Z)$;
and
- 9) $0.9 DL \pm (0.3 EL_X \pm 0.3 EL_Y \pm EL_Z)$.
- c) soil by the working stress method:
- 1) $1.0 DL + 1.0 IL \pm (EL_X \pm 0.3 EL_Y \pm 0.3 EL_Z)$;
- 2) $1.0 DL + 1.0 IL \pm (0.3 EL_X \pm EL_Y \pm 0.3 EL_Z)$;
- 3) $1.0 DL + 1.0 IL \pm (0.3 EL_X \pm 0.3 EL_{DY} \pm EL_Z)$;
- 4) $1.0 DL \pm (EL_X \pm 0.3 EL_Y \pm 0.3 EL_Z)$;
- 5) $1.0 DL \pm (0.3 EL_X \pm EL_Y \pm 0.3 EL_Z)$;
- 6) $1.0 DL \pm (0.3 EL_X \pm 0.3 EL_Y \pm EL_Z)$;
- 7) $0.9 DL \pm (EL_X \pm 0.3 EL_Y \pm 0.3 EL_Z)$;
- 8) $0.9 DL \pm (0.3 EL_X \pm EL_Y \pm 0.3 EL_Z)$;
and
- 9) $0.9 DL \pm (0.3 EL_X \pm 0.3 EL_Y \pm EL_Z)$.
- 4) $1.2 DL + 1.2 IL \pm (0.3 EL_Y \pm EL_Z)$;
- 5) $1.5 DL \pm (EL_X \pm 0.3 EL_Z)$;
- 6) $1.5 DL \pm (0.3 EL_X \pm EL_Z)$;
- 7) $1.5 DL \pm (EL_Y \pm 0.3 EL_Z)$;
- 8) $1.5 DL \pm (0.3 EL_Y \pm EL_Z)$;
- 9) $0.9 DL \pm (EL_X \pm 0.3 EL_Z)$;
- 10) $0.9 DL \pm (EL_Y \pm 0.3 EL_Z)$;
- 11) $0.9 DL \pm (0.3 EL_X \pm EL_Z)$; and
- 12) $0.9 DL \pm (0.3 EL_Y \pm EL_Z)$.
- b) structural elements of masonry structures by the working stress method:
- 1) $1.0 DL + 1.0 IL \pm (EL_X \pm 0.3 EL_Z)$;
- 2) $1.0 DL + 1.0 IL \pm (0.3 EL_X \pm EL_Z)$;
- 3) $1.0 DL + 1.0 IL \pm (0.3 EL_Y \pm EL_Z)$;
- 4) $1.0 DL + 1.0 IL \pm (EL_Y \pm 0.3 EL_Z)$;
- 5) $1.0 DL + (EL_X \pm 0.3 EL_Z)$;
- 6) $1.0 DL + (0.3 EL_X \pm EL_Z)$;
- 7) $1.0 DL + (0.3 EL_Y \pm EL_Z)$;
- 8) $1.0 DL + (EL_Y \pm 0.3 EL_Z)$;
- 9) $0.9 DL \pm (EL_X \pm 0.3 EL_Z)$;
- 10) $0.9 DL \pm (0.3 EL_X \pm EL_Z)$;
- 11) $0.9 DL \pm (EL_Y \pm 0.3 EL_Z)$; and
- 12) $0.9 DL \pm (0.3 EL_Y \pm EL_Z)$.
- c) soil by the working stress method:
- 1) $1.0 DL + 1.0 IL \pm (EL_X \pm 0.3 EL_Z)$;
- 2) $1.0 DL + 1.0 IL \pm (0.3 EL_X \pm EL_Z)$;
- 3) $1.0 DL + 1.0 IL \pm (0.3 EL_Y \pm EL_Z)$;
- 4) $1.0 DL + 1.0 IL \pm (EL_Y \pm 0.3 EL_Z)$;
- 5) $1.0 DL + (EL_X \pm 0.3 EL_Z)$;
- 6) $1.0 DL + (0.3 EL_X \pm EL_Z)$;
- 7) $1.0 DL + (0.3 EL_Y \pm EL_Z)$;
- 8) $1.0 DL + (EL_Y \pm 0.3 EL_Z)$;
- 9) $0.9 DL \pm (EL_X \pm 0.3 EL_Z)$;
- 10) $0.9 DL \pm (0.3 EL_X \pm EL_Z)$;
- 11) $0.9 DL \pm (EL_Y \pm 0.3 EL_Z)$; and
- 12) $0.9 DL \pm (0.3 EL_Y \pm EL_Z)$.

But, effects of earthquake ground shaking along one horizontal direction plus design earthquake load along the vertical direction (that is one plan direction and vertical direction) may be considered in the design of normal structures, which are regular in plan and in elevation and located in zones III and IV.

And, the load combinations specified in 8.4.1 shall be replaced with:

- a) structural elements (including structural elements of foundations) of concrete and steel structures by the limit state method:
- 1) $1.2 DL + 1.2 IL \pm (EL_X \pm 0.3 EL_Z)$;
- 2) $1.2 DL + 1.2 IL \pm (EL_Y \pm 0.3 EL_Z)$;
- 3) $1.2 DL + 1.2 IL \pm (0.3 EL_X \pm EL_Z)$;

8.5 Design Demand

8.5.1 Designing for Effects from Earthquake Load Combinations

A structure, its structural elements and the soil underneath shall be designed (as per IS 13920 (Part 1) and respective part of IS 13920 depending on the type of the structure) for the effects of dead

load, imposed load and earthquake ground shaking combined as per the basic load combinations specified in 8.4.

8.5.2 Designing for Effects from Non-Earthquake Load Combinations

Even when the load combinations that do not involve earthquake load indicate larger demands than those including earthquake loads (as specified in 8.4), the provisions of IS 13920 (Part 1) and of the respective part of IS 13920 depending on the type of the structure, shall be complied with.

9 GEOTECHNICAL ASPECTS

The additional geotechnical aspects required in earthquake-resistant design of structures shall be taken as specified hereunder.

9.1 Soil Properties

9.1.1 Basic Input

9.1.1.1 The basic input related to soils underneath foundations:

- a) Corrected N values can be used in the following cases:
 - 1) Normal structures in all earthquake zones; and
 - 2) Important structures in earthquake Zones II and III.

When V_S profiles are available, the same shall be preferred over the corrected N values. When corrected N values are used, the correlation between the corrected N values and the V_S values shall be taken as specified in 6.2.3.1.

- b) In all other structures, V_S values shall be determined based on geophysical investigations at the site.

9.1.1.2 For the purposes of estimating the stiffness and strength of the soil layers underneath, the required geophysical and geotechnical investigations shall be undertaken at least up to the depth of influence below the founding level specified in Table 5. In select cases (with soil strata being highly irregular in the landmass around the site of the structure), the depths of influence below the founding level specified in Table 5 may not suffice. In such cases, due diligence is required to finalize the depths of influence and hence of the required depth of geophysical and geotechnical investigations.

9.1.2 Soil Flexibility

9.1.2.1 Applicability

The flexibility of soil shall be considered in the

following cases:

- a) Critical and special structures in all earthquake zones;
- b) Important structures in earthquake Zones IV, V and VI;
- c) All structures resting on site of class C and D (as per 6.2.3.1); and
- d) Structures in which effects of geometric nonlinearity enhances the stress-resultants by more than 15 percent.

9.1.2.2 Modulus of subgrade reaction

- a) The flexibility of soil at each soil layer shall be captured through its modulus of subgrade reaction (in kN/m^3), which shall be estimated as:

$$k_{\text{HB}} = k_{\text{H0}} \left(\frac{B_{\text{HF}}}{0.30} \right)^{-0.75} \text{ on horizontal surface}$$

$$k_{\text{VB}} = k_{\text{V0}} \left(\frac{B_{\text{VF}}}{0.30} \right)^{-0.75} \text{ on vertical surface}$$

$$k_{\text{HS}} = \lambda k_{\text{VB}} \text{ on horizontal surface}$$

$$k_{\text{VS}} = \lambda k_{\text{HB}} \text{ on vertical surface}$$

where

$$k_{\text{H0}} = \begin{cases} \frac{2.0}{0.30} E_{\text{D}} & \text{Footings, rafts and piles} \\ \frac{2.4}{0.30} E_{\text{D}} & \text{Well foundations;} \end{cases}$$

$$k_{\text{V0}} = \begin{cases} \frac{2.0}{0.30} E_{\text{D}} & \text{Footings, rafts and piles} \\ \frac{2.4}{0.30} E_{\text{D}} & \text{Well foundations; and} \end{cases}$$

$$\lambda = \begin{cases} \frac{1}{4} & \text{Saturated condition} \\ \frac{1}{3} & \text{Unsaturated condition.} \end{cases}$$

In which

$$E_{\text{D}} = 2 (1 + \nu_{\text{S}}) G_{\text{D}}$$

$$G_{\text{D}} = \frac{1}{1000} \rho V_{\text{SD}}^2$$

wherein

ν_{S} = Poisson's ratio of soil

$$V_{\text{SD}} = \begin{cases} 0.8 V_{\text{S}} & \text{if } V_{\text{S}} \leq 300 \text{ m/s} \\ V_{\text{S}} & \text{if } V_{\text{S}} > 300 \text{ m/s} \end{cases}$$

- b) When V_{S} is not available directly from field investigations, it shall be taken as per 6.2.3.1.
- c) In the above expressions, ρ is the mass density (in kg/m^3) of soil, and B_{HF} (m) and B_{VF} (m) depend on the foundation type (see Fig. 3), which are described hereunder. The above values of modulus of subgrade

reaction shall be multiplied with the corresponding contributory area of the foundation element to obtain the stiffness of the representative soil springs at the respective node.

1) *Individual footings and raft foundations*

The modulus of subgrade reaction of soil in vertical bearing k_{VB} and horizontal shear k_{HS} at the bottom face of the footing shall be estimated using:

$$B_{HF} = \sqrt{A_{HF}}$$

where

A_{HF} = horizontal plan area (in m^2) of the representative slice of the foundation element being considered at the level where the vertical spring is being provided

2) *Pile foundations*

The modulus of subgrade reaction of soil in horizontal bearing k_{VB} and vertical shear k_{VS} at the vertical face of the pile shall be estimated using:

$$B_{VF} = B_{VP} = \sqrt{\frac{D_p}{\beta}}$$

where

D_p = diameter of pile, or effective dimension of the pile group in the direction of shaking

$$\beta = \sqrt[4]{\frac{k_{HB} D_p}{4(EI)_p}}$$

k_{HB} = stiffness of the horizontal soil spring per unit length of the pile, and

$(EI)_p$ = flexural rigidity of pile, or effective flexural rigidity of the pile group in the direction of shaking.

Here, the flexibility offered by the soil at the tip of the pile is neglected. When piles are anchored into hard rock, the end shall be considered to be restrained therein.

3) *Well foundations*

The modulus of subgrade reaction of soil in horizontal bearing k_{HB} and in

vertical shear k_{VS} at the side face of the foundation element (well), and in vertical bearing k_{VB} and horizontal shear k_{HS} at the bottom face of the foundation element (well plug) shall be estimated using:

$$B_{HF} = B_{HW} = \sqrt{A_{HW}}$$

$$B_{VF} = B_{VW} = \sqrt{A_{VW}}$$

where

A_{HW} = horizontal plan area (in m^2) of the representative well being considered at the level where the vertical normal and horizontal shear springs are provided; and

A_{VW} = vertical projected area (in m^2) of the representative slice of the well being considered at the level where the horizontal normal and vertical shear springs are provided.

9.1.3 Soil Strength

9.1.3.1 Shear strength capacity

The shear strength of soil shall be reflected by its dynamic shear modulus G_D . Fig. 4 shall be used for estimating the degradation in G_D of soils with different plasticity indices. The maximum dynamic shear modulus G_{max} of soils (see Fig. 4) shall be obtained from geophysical tests, or bender element tests.

9.1.3.2 Bearing capacity

The ultimate earthquake bearing capacity q_{uE} of strip footing (see Fig. 5) shall be taken as:

$$q_{uE} = cN_{cE} + \gamma d N_{qE} + 0.5\gamma B N_{\gamma E}$$

where

c = cohesion of soil;

N_{cE} = $(N_{qE} - 1) \cot \phi$;

γ = unit weight of soil;

d = depth of footing;

N_{qE} = $\frac{K_{PE}}{K_{AE}}$;

B = breadth of footing; and

$N_{\gamma E}$ = $\left(\frac{K_{PE}}{K_{AE}} - 1\right) \tan \rho_{AE}$.

In which

$$K_{PE} = \text{earthquake passive earth pressure coefficient}$$

$$= \frac{\cos^2(\phi - \theta)}{\cos \theta \cos(\delta + \theta) \left\{ 1 - \sqrt{\frac{\sin(\delta + \phi) \sin(\phi - \theta)}{\cos(\delta + \theta)}} \right\}^2}$$

$$K_{AE} = \text{earthquake active earth pressure coefficient}$$

$$= \frac{\cos^2(\phi - \theta)}{\cos \theta \cos(\delta + \theta) \left\{ 1 + \sqrt{\frac{\sin(\delta + \phi) \sin(\phi - \theta)}{\cos(\delta + \theta)}} \right\}^2}$$

$$\rho_{AE} = \text{smaller of } (a + \alpha_{AE}) \text{ and } (-a + \alpha_{PE})$$

$$\theta = \tan^{-1} \left[\frac{A_H}{1 - A_V} \right] > 0$$

$$\phi = \text{angle of repose of soil}$$

wherein

$$a = \phi - \theta$$

$$\delta = \frac{\phi}{2}$$

$$\alpha_{AE} = \tan^{-1} \left[\frac{-\tan a + \sqrt{1 + \tan^2 a} \{1 + \tan(\delta + \theta) \cot a\}}{1 + \tan(\delta + \theta) (\tan a + \cot a)} \right]$$

$$\alpha_{PE} = \tan^{-1} \left[\frac{\tan a + \sqrt{1 + \tan^2 a} \{1 + \tan(\delta - \theta) \cot a\}}{1 + \tan(\delta + \theta) (\tan a + \cot a)} \right]$$

A_H and A_V are design horizontal and vertical acceleration coefficients as specified in 6.2.3.4.

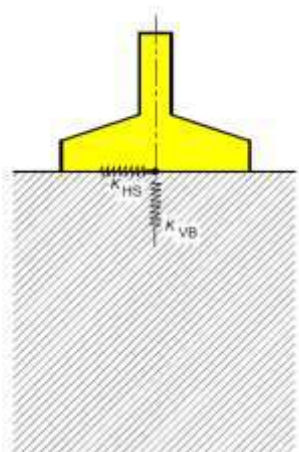

FIG. 3A INDIVIDUAL FOOTING

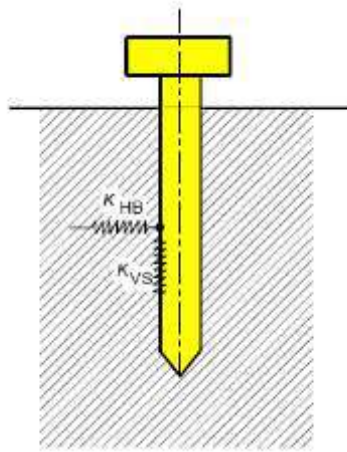

FIG. 3B PILE

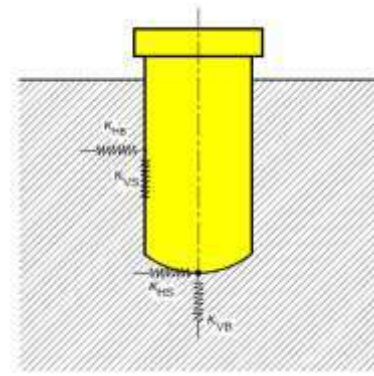

FIG. 3C WELL

FIG. 3 PARAMETERS TO BE USED IN ESTIMATION OF MODULUS OF SUBGRADE REACTION IN DIFFERENT FOUNDATIONS

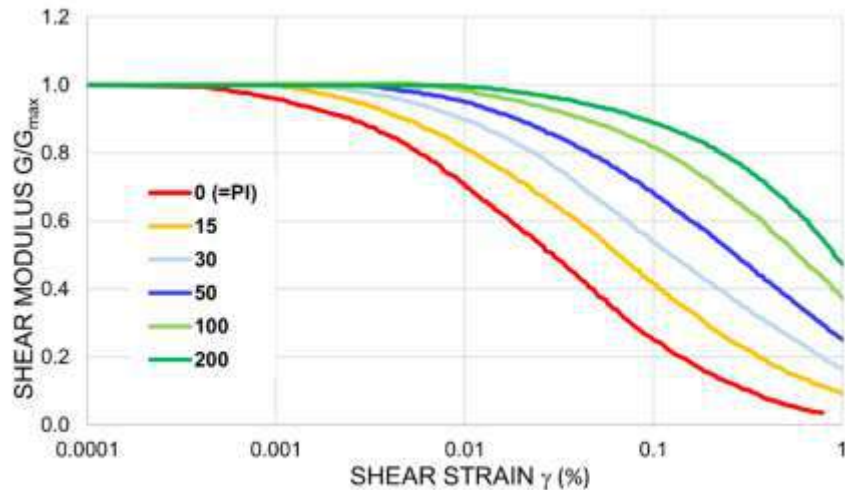

FIG. 4 TYPICAL NORMALISED SHEAR MODULUS G_D/G_{MAX} — SHEAR STRAIN γ CURVE OF SOIL FOR DIFFERENT VALUES OF PLASTICITY INDEX FOR ANY VALUE OF σ'_m

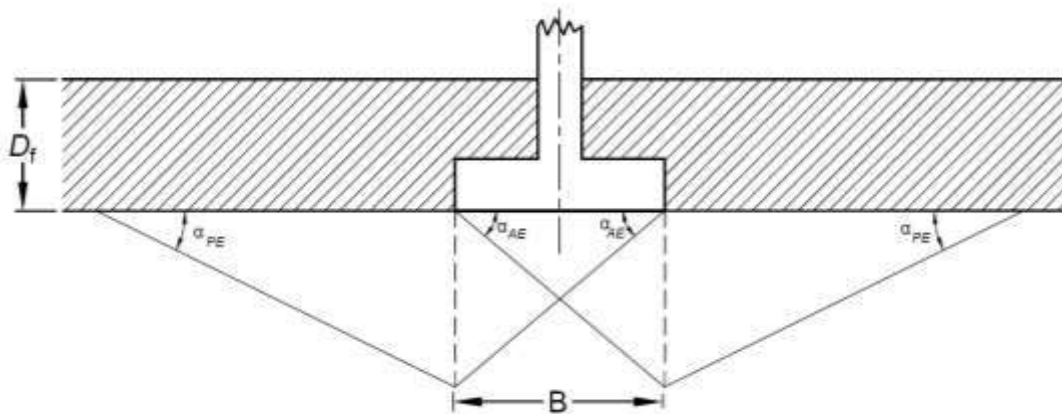

FIG. 5 FAILURE SURFACE TO BE ASSUMED IN SOIL FOR EARTHQUAKE BEARING CAPACITY ANALYSIS

9.1.4 Soil Damping

9.1.4.1 For the design of any soil system, the damping ratio of soil shall be taken as 5 percent of critical damping. But, for assessment of structures under earthquake loading, strain-dependent hysteretic damping shall be used instead of viscous damping, when modelling soil.

9.1.4.2 Radiation damping shall be accounted for in structural analysis of structure-foundation-soil system using finite element method with infinite boundary elements.

9.2 Liquefaction

The assessment of liquefaction potential of site shall be carried out as specified here under.

9.2.1 Estimation of Cyclic Stress Ratio

The demand on the soil shall be estimated through the cyclic stress ratio (CSR) induced by the

earthquake using the expression:

$$CSR = 0.65 \left(\frac{a_{Max}}{g} \right) \left(\frac{\sigma_{vo}}{\sigma'_{vo}} \right) r_d$$

where

- a_{max} = peak ground acceleration (PGA);
- σ_{vo} = total vertical overburden stress at the chosen depth in the potentially liquefiable layers within the deposit;
- r_d = stress reduction coefficient;
= $e^{\alpha_z + \beta_z M}$;
- g = acceleration due to gravity; and
- σ'_{vo} = effective vertical overburden stress at the chosen depth in the potentially liquefiable layers within the deposit.

in which

$$\alpha_z = -1.012 - 1.126 \sin \left(\frac{z}{11.73} + 5.133 \right)$$

$$\beta_z = 0.106 + 0.118 \sin \left(\frac{z}{11.28} + 5.142 \right)$$

M = magnitude of largest likely earthquake

z = depth, in m, below the ground surface

If value of PGA is not available, the ratio (a_{\max}/g) may be taken equal to earthquake zone factor Z (as per 6.2.2.2) corresponding to the return period considered for the design of the structure which will be rested on this site for which liquefaction potential is being assessed.

9.2.2 Estimation of Cyclic Resistance Ratio

The capacity of the soil shall be estimated through the cyclic resistance ratio CRR for an earthquake of magnitude loading using the expression:

$$CRR = CRR_{M_w = 7.5, \sigma'_v = 1 \text{ atm.}} (MSF) K_\sigma$$

where

$$MSF = \text{magnitude scaling factor} = 1 + (MSF_{Max} - 1)(8.64e^{-0.25M} - 1.325);$$

and

$$K_\sigma = \text{overburden stress correction factor} = \left[1 - C_\sigma \ln \left(\frac{\sigma'_{v0}}{P_a} \right) \right] \leq 1.1$$

in which

MSF_{Max} = maximum value of magnitude scaling factor

$$= \begin{cases} 1.09 \left(\frac{q_{c1Ncs}}{180} \right)^3 \leq 2.2 & \text{from CPT} \\ 1.09 \left(\frac{(N_1)_{60cs}}{31.5} \right)^2 \leq 2.2 & \text{from SPT} \end{cases}$$

$$C_\sigma = \begin{cases} \frac{1}{37.3 - 8.27(q_{c1NCS})^{0.264}} \leq 0.3 & \text{from CPT} \\ \frac{1}{18.9 - 2.55\sqrt{(N_1)_{60CS}}} \leq 0.3 & \text{from SPT} \end{cases}$$

M = magnitude of largest likely earthquake

P_a = atmospheric pressure

Alternately, Fig. 6 shall be used to estimate $CRR_{M_w} = 7.5$.

Unless otherwise specified, the magnitude to be considered at each site shall be taken from Table 6. But, for the purpose of liquefaction potential assessment analysis at sites in the area around *Koyna*, the M_{Max} for the earthquake Zone IV and Zone V shall be taken as 6.5.

Table 6 Magnitudes to be Considered in Liquefaction Potential Assessment Depending on the Earthquake Zone in which the Site is Located

(Clause 9.2.2)

Sl No.	Earthquake Zone	Magnitude M_w
(1)	(2)	(3)
i)	VI	8.0
ii)	V	7.5
iii)	IV	7.0
iv)	III	6.5
v)	II	6.0

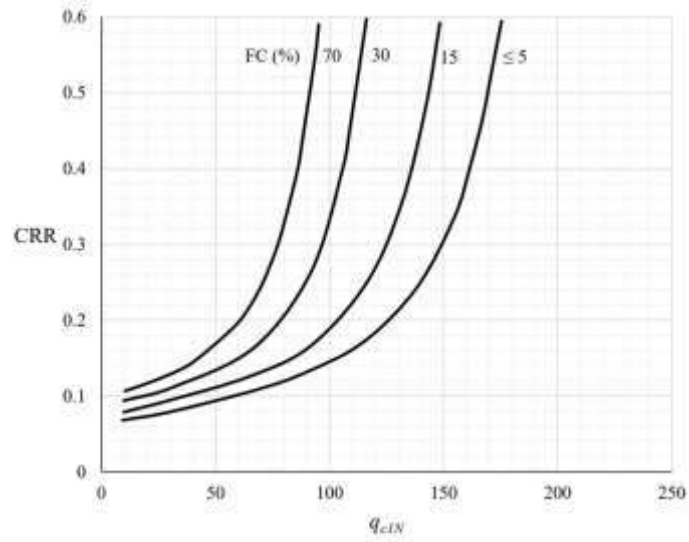

FIG. 6(A) CPT

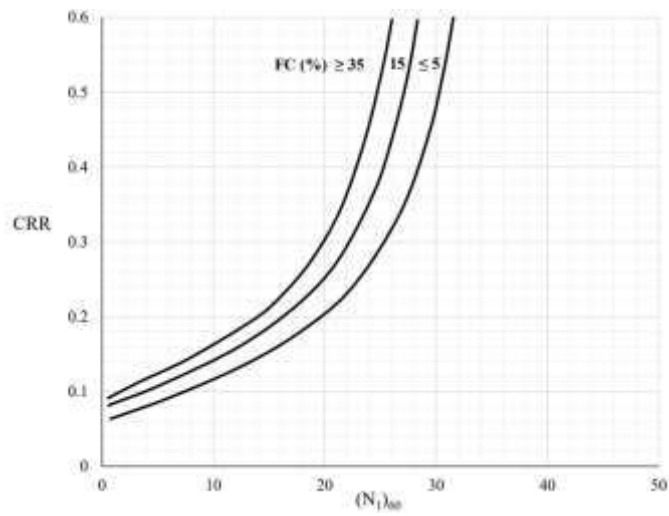

FIG. 6(B) SPT

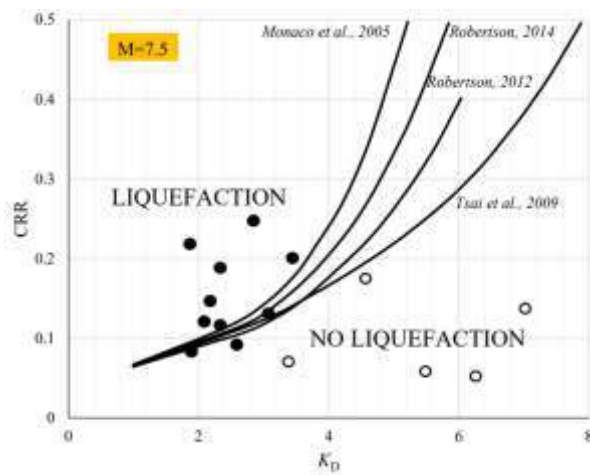

FIG. 6(C) DMT

FIG. 6 $CRR_{M_W=7.5}$ ESTIMATED FROM DIFFERENT GEOTECHNICAL TESTS

a) For clean sand and sand with non-plastic fines

1) From the cone penetration test (CPT)

$$CRR = CRR_{M_W=7.5, \sigma'_{v0}=1atm} = e^{\left[\left(\frac{q_{c1Ncs}}{113} \right) + \left(\frac{q_{c1Ncs}}{1000} \right)^2 - \left(\frac{q_{c1Ncs}}{140} \right)^3 + \left(\frac{q_{c1Ncs}}{137} \right)^4 - 2.8 \right]}$$

where

$$q_{c1Ncs} = q_{c1N} + \Delta q_{c1N}$$

in which

$$q_{c1N} = C_N q_{CN}, \text{ and}$$

$$\Delta q_{c1N} = \left(11.9 + \frac{q_{c1N}}{14.6} \right) e^{\left[1.63 - \left(\frac{9.7}{FC+2} \right) - \left(\frac{15.7}{FC+2} \right)^2 \right]}$$

wherein

$$q_{CN} = \frac{q_t}{P_a}$$

$$C_N = \left(\frac{P_a}{\sigma'_{vc}} \right)^m \leq 1.7$$

$$m = 1.338 - 0.249(q_{c1Ncs})^{0.264} \text{ for } 21 \leq q_{c1Ncs} \leq 175$$

σ'_{vc} = effective vertical consolidation stress

This expression is valid when $0.246 \leq m \leq 0.782$. For other values of m , Fig. 6A may be used.

Fines content (FC) can be estimated as:

$$FC = 80(I_C + C_{FC}) - 137$$

where

$$I_C = \text{soil behaviour type index} = \sqrt{(3.47 - \log Q)^2 + (1.22 + \log F)^2}; \text{ and}$$

$$C_{FC} = -0.07,$$

wherein

$$Q_{tn} = \text{normalised tip resistance} = \left(\frac{q_t - \sigma_{vc}}{P_a} \right) \left(\frac{P_a}{\sigma'_{vc}} \right)^n$$

$$F = \text{sleeve friction ratio} = 100 \left(\frac{f_s}{q_t - \sigma_{vc}} \right)$$

in which

$$q_t = \text{cone tip resistance}$$

$$n = 0.5 \text{ for sand and } 1.0 \text{ for clay}$$

$$f_s = \text{sleeve friction, estimated using frictional force } F_s \text{ on frictional sleeve of surface area } A_s$$

$$= \frac{F_s}{A_s}$$

$$\sigma_{vc} = \text{total vertical consolidation stress}$$

Alternately, $CRR_{M_W=7.5, \sigma'_{v0}=1atm}$ can be estimated from Fig. 6A.

2) From the standard penetration test (SPT)

$$CRR = CRR_{M_W=7.5, \sigma'_{v0}=1atm} = e^{-2.8 + \left(\frac{(N_1)_{60cs}}{14.1} \right) + \left(\frac{(N_1)_{60cs}}{126} \right)^2 - \left(\frac{(N_1)_{60cs}}{23.6} \right)^3 + \left(\frac{(N_1)_{60cs}}{25.4} \right)^4}$$

where

$$(N_1)_{60CS} = (N_1)_{60} + \Delta(N_1)_{60};$$

$$(N_1)_{60} = C_N N_{60}; \text{ and}$$

$$N_{60} = C_N C_E C_R C_B C_S N_m.$$

in which

$$\Delta(N_1)_{60} = e^{1.63 + \frac{9.7}{FC + 0.01} - \left(\frac{15.7}{FC + 0.01}\right)^2}$$

$$C_N = \left(\frac{p_a}{\sigma'_v}\right)^m \leq 1.7$$

wherein

$$m = 0.784 - 0.076 \sqrt{(N_1)_{60CS}}$$

Factors C_E , C_R , C_B , and C_S are provided in Table 7 as recommended by different studies for some common non-standard SPT configurations. When SPT is conducted as per IS 2131, the energy delivered to the drill rod is about 60 percent. Therefore, C_{60} may be assumed as 1. The computed N_{60} is normalised with an effective overburden pressure of approximately 100 kPa using overburden correction factor C_N .

Alternately, $CRR_{M_W=7.5, \sigma'_v=1atm}$ can be estimated from Fig. 6B.

3) From the dilatometer test (DMT)

$$CRR = CRR_{M_W=7.5, \sigma'_v=1atm} = [93(0.025K_D)^2 + 0.08] \leq 1.0$$

for $2 < K_D < 6$, and $I_D > 1.2$

where

$$K_D = \text{horizontal stress index} = (p_1 - p_0)/\sigma'_{vo}; \text{ and}$$

$$I_D = \text{material index} = (p_1 - p_0)/(p_0 - u_0).$$

Here, the flat dilatometer shall have a stainless-steel blade with a flat circular steel membrane mounted flush on one side. This expression for CRR is valid for the specified range of values of K_D and I_D . For values of K_D and I_D outside this range, Fig. 6C may be used.

Alternately, $CRR_{M_W=7.5, \sigma'_v=1atm}$ can be estimated from Fig. 6C.

4) From shear wave velocity (V_s):

$$CRR_{M_W=7.5} = a \left(\frac{V_{s1}}{100}\right)^2 + b \left(\frac{1}{V_{s1}^* - V_{s1}} - \frac{1}{V_{s1}^*}\right)$$

where

$$a = 0.022;$$

$$V_{s1} = \text{overburden stress corrected shear wave velocity (m/s)}$$

$$= \left(\frac{p_a}{\sigma'_{vo}}\right)^{0.25} V_s \text{ for clean sands;}$$

$$b = 2.8;$$

$$V_{s1}^* = \text{limiting upper value of } V_{s1} \text{ (m/s) for liquefaction occurrence}$$

$$= \begin{cases} 200 + 15 \left(\frac{35 - FC}{30}\right) & 35 < FC < 5; \text{ and} \\ 215 & 5 \leq FC \end{cases}$$

$$\sigma'_{vo} = \text{effective vertical overburden stress at the chosen depth in the potentially liquefiable layers within the deposit.}$$

b) For clay and plastic silt

CRR = cyclic resistance ratio

$$= \begin{cases} 0.053Q_{tn} & \text{from CPT} \\ 0.074K_D^{1.25} & \text{from DMT} \\ 0.18(OCR)^{0.8} & \text{from empirical Method} \end{cases}$$

where

$$Q_{tn} = \text{normalised tip resistance} = \left(\frac{q_t - \sigma_{vc}}{P_a} \right) \left(\frac{P_a}{\sigma'_{vc}} \right)^{n^*};$$

$$K_D = \text{horizontal stress index} = \frac{p_1 - p_0}{\sigma'_{vo}};$$

OCR = over-consolidation stress ratio ascertained by geotechnical investigations; and

n^* = 0.5 for sand and 1.0 for clay.

Table 7 Correction Factors for Non-Standard Procedures and Equipment

(Clause 9.2.2)

SI No.	Factor	Description
(1)	(2)	(3)
i)	Energy ratio ER_m	$C_E = ER_m/60$ where ER_m = measured energy ratio, a percent of theoretical maximum. In the absence of energy measurements, empirical estimates of C_E (for rod lengths of 10 m or more) shall be taken as: $C_E = \begin{cases} 0.5 - 1.0 & \text{Doughnut hammer} \\ 0.7 - 1.2 & \text{Safety hammer} \\ 0.8 - 1.3 & \text{Automatic trip hammer} \end{cases}$
ii)	Borehole diameter φ_{BH}	$C_B = \begin{cases} 1.00 & \varphi_{BH} \sim 65 \text{ mm} - 115 \text{ mm} \\ 1.05 & \varphi_{BH} \sim 150 \text{ mm} \\ 1.15 & \varphi_{BH} \sim 200 \text{ mm} \end{cases}$
iii)	Rod length L_R	$C_R = \begin{cases} 0.75 & L_R < 3 \text{ m} \\ 0.80 & 3 \text{ m} \leq L_R < 4 \text{ m} \\ 0.85 & 4 \text{ m} \leq L_R < 6 \text{ m} \\ 0.95 & 6 \text{ m} \leq L_R < 10 \text{ m} \\ 1.00 & 10 \text{ m} \leq L_R < 30 \text{ m} \end{cases}$
iv)	Sampler	When the sampler is a standard split spoon without room for liners, where the inside diameter is 35 mm: $C_S = 1$ When the sampler is a split-spoon sampler with room but with the liners absent, which increases the inside diameter to 28.6 mm behind the driving shoe: $C_S = \begin{cases} 1.1 & (N_1)_{60} \leq 10 \\ 1.0 + 0.01(N_1)_{60} & 10 < (N_1)_{60} \leq 30 \\ 1.3 & 30 < (N_1)_{60} \end{cases}$

9.2.3 Assessing Liquefaction Potential of a Site

The factor of safety FS_{liq} against liquefaction shall be estimated using:

$$FS_{liq} = \frac{CRR}{CSR}$$

where CSR and CRR are as estimated in 9.2.1 and 9.2.2.

If FS_{liq} is:

a) less than 1.2, then the soil layer shall be

considered unsafe against liquefaction;

b) between 1.2 and 1.4, then the ground settlement resulting from the earthquake loading shall be verified based on Fig. 7, depending on the relative density R_D of soil layer; and

c) more than 1.4, then the soil layer may be considered safe against liquefaction.

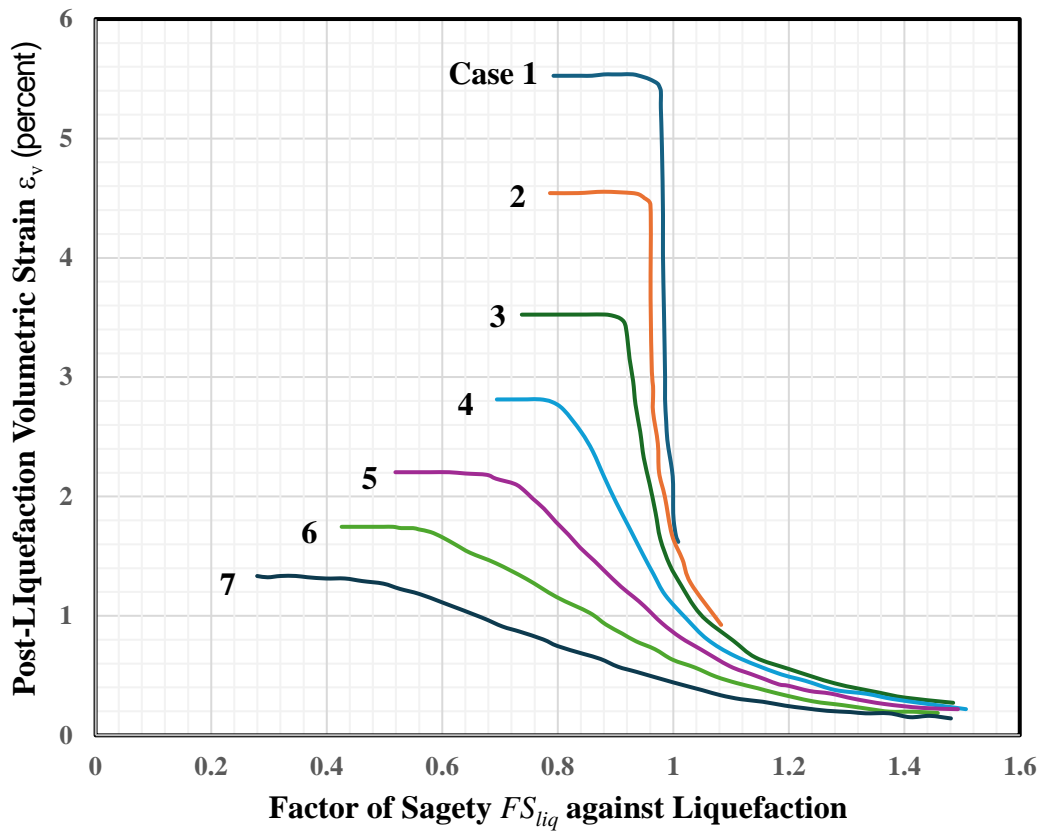

Case	D_R (in percent)	$(N_1)_{60}$	q_{c1N}
1	30	4	60
2	40	7	80
3	50	12	100
4	60	17	125
5	70	23	160
6	80	29	195
7	90	37	235

FIG. 7 FS_{liq} ESTIMATED FROM POST-LIQUEFACTION VOLUMETRIC STRAIN

10 ARCHITECTURAL ELEMENTS AND UTILITIES

Architectural elements and utilities (*AEUs*) in all structures shall be designed to remain fully functional in the aftermath of the design earthquake shaking.

10.1 Classification of *AEUs*

AEUs shall be classified based on earthquake behaviour into three types, namely:

- a) *Acceleration-sensitive AEUs (A-AEUs)* — stiff and massive *AEUs*, which slide and/or topple at the level of their base, during earthquake shaking;
- b) *Deformation-sensitive AEUs (D-AEUs)* — flexible and long *AEUs*, which move or swing by large amounts in translation and/or rotation, during earthquake shaking; and
- c) *Acceleration-cum-deformation-sensitive AEUs (AD-AEUs)* — massive and long *AEUs*, which sustain both effects mentioned in (a) and (b) above.

Table 8, Table 9 and Table 10 provide lists of some *AEUs* based on their usage in the structures.

10.2 Protection of *AEUs*

AEUs shall be protected by the following three methods:

- a) *Non-engineered method*
This method shall be used when it is not possible to hold each *AEU* individually. The owner and/or the architect shall pre-empt simple ways to protect the *AEUs* and implement the same;
- b) *Pre-engineered method*
This method shall be used when it is possible to hold each *AEU* individually,

and the *AEU* is made in large numbers in a factory. The manufacturer (with the architect and/or the structural engineer) shall pre-design the connections and provide the required fittings along with the *AEU* for different earthquake zones.

- c) *Engineered method*

This method shall be used when an *AEU* is assembled using many individual *AEUs*, and/or the *AEU* is assembled at the site. The architect and/or the structural engineer shall design the required fittings along with the *AEU*.

This standard provides details related to the pre-engineered method and the engineered method.

10.3 Load Effects for Design of System to Protect *AEUs*

For the design of the *AEUs*, the design earthquake hazard (that is, acceleration and displacement) shall be taken as below.

10.3.1 *Acceleration-Sensitive A-AEUs*

The design earthquake lateral force demand on the *A-AEU* specified in **10.5.1** shall be considered to design the anchorage system to protect them.

10.3.2 *Displacement-Sensitive D-AEUs*

The design earthquake relative lateral displacement demand on the *D-AEU* specified in **10.5.2** shall be considered to design the connection system to protect them.

10.3.3 *Acceleration-cum-Displacement-Sensitive AD-AEUs*

The design earthquake lateral force demand and design earthquake relative lateral displacement demand on the *AD-AEU* specified in **10.5.1** and **10.5.2** shall be considered to design the connection system to protect them.

Table 8 List of Select AEU's Used as Contents and Architectural Finishes Inside Structures

(Clause 10.1)

Sl No.	Sub-Category	Architectural Elements and Utilities	Sensitivity		
			A-AEU's	D-AEU's	Both
(1)	(2)	(3)	(4)	(5)	(6)
i)		Building Contents			
	a) Furniture and minor items (standalone and built-in)	1) Cabinets	✓		
		2) Multi-level storage racks	✓		
		3) Book shelves	✓		
		4) Large sofa sets	✓		
		5) Large tables	✓		
		6) Cupboards	✓		
		7) Wall mountings	✓		
	b) Appliances	1) Refrigerators	✓		
		2) Washing machines	✓		
		3) Gas cylinders	✓		
		4) Wall and table mounted TVs	✓		
		5) Diesel generators	✓		
		6) Water pumps (small)	✓		
		7) Window air-conditioners	✓		
		8) Wall mounted air-conditioners	✓		
ii)		Architectural Finishes Inside Structures			
	a) Openings	1) Doors and windows	Secondary	Primary	✓
		2) Large-panel glass panes and ACPs with frames (as windows or infills)	Secondary	Primary	✓
		3) Other partitions	Secondary	Primary	✓
	b) False ceilings	1) Supported on a secondary system integrated with the ceiling, or on the vertical elements of the lateral force resisting system	✓		
		2) Directly hung from ceiling	Secondary	Primary	✓
	c) Stairs	1) All staircases	Secondary	Primary	✓
	d) Partitions	1) Not held snugly between SEs	Primary	Secondary	✓
		2) Held snugly between SEs	✓		
	e) Appendage	1) Tiles and other claddings (ceramic, stone, glass or other) pasted on, bolted to, or hung from hooks bolted to vertical surface	✓		
		2) Composite large panels	Primary	Secondary	✓
		3) Paintings to walls and ceilings		✓	

Sl No.	Sub-Category	Architectural Elements and Utilities	Sensitivity		
			A-AEUs	D-AEUs	Both
(1)	(2)	(3)	(4)	(5)	(6)
	f) Hangings	1) Chandeliers	Secondary	Primary	✓
		2) Building maintenance unit	Secondary	Primary	✓
		3) Restraint systems hung from ceilings			
	g) Wall mountings	4) Huge wall paintings	Secondary	Primary	✓
iii)		Equipment			
	a) Sensitive equipment	1) Ventilator	✓		
		2) Boyles apparatus	✓		
		3) Bedside monitors	✓		
		4) Defibrillators	✓		
		5) Peritoneal dialysis machine	✓		
		6) Infant radiant warmer	✓		
		7) Phototherapy unit	✓		
		8) Operating microscope	✓		
	b) Special equipment	1) Colour doppler	✓		
		2) Endoscopes	✓		
		3) Slit lamp with applanation tonometer	✓		
		4) Portable X-Ray machine	✓		
		5) ECG machine	✓		
		6) Ultrasound machine	✓		
		7) Oxygen concentrator	✓		
		8) Automatic cell counter	✓		
	c) Generic equipment	1) CT scan machine	✓		
		2) Centrifuge machine	✓		
		3) Blood bank refrigerator	✓		
		4) Deep freezer	✓		
		5) Operating table	✓		
		6) EEG machine	✓		
		7) Blood cell separator	✓		
		8) Impedance audiometer	✓		
		9) Autoclave	✓		

Table 9 List of Select AEUs Used as Appendages on Structures and as Standalone Items in Open Ground

(Clause 10.1)

Sl No.	Sub-Category	Architectural Elements and Utilities	Sensitivity		
			A-AEUs	D-AEUs	Both
(1)	(2)	(3)	(4)	(5)	(6)
i)	Interior and exterior facades	1) Tiles and other claddings (ceramic, stone, glass or other) pasted on, bolted to, or hung from hooks bolted to vertical surface	✓		
		2) Composite large panels	Primary	Secondary	✓
ii)	Vertical projections	1) Chimneys and stacks	✓		
		2) Parapets	✓		
		3) Water tanks (small)	✓		
		4) Hoardings anchored on roof tops	✓		
		5) Antennas and communication towers on roof tops	✓		
		6) Solar panels on vertical walls or roof tops	✓		
		7) Bust (memoir) on standalone stub	✓		
		8) Building maintenance unit (BMU) restraint systems located on roof tops			
iii)	Horizontal projections	1) Sunshades and exterior shading systems	✓		
		2) Canopies, awnings, and marques	✓		
		3) Hoardings anchored to vertical face	Secondary	Primary	✓
iv)	Exterior structural glazing systems	All types	Secondary	Primary	✓

Table 10 List of Select AEU's used as Services and Utilities

(Clause 10.1)

SI No.	Sub-Category	Architectural Elements and Utilities	Sensitivity		
			A-AEU's	D-AEU's	Both
(1)	(2)	(3)	(4)	(5)	(6)
i)	From within and from outside to inside the building	1) Water supply pipelines		✓	
		2) Electricity cables and wires		✓	
		3) All gas pipelines		✓	
		4) Drainage (sewage) pipelines		✓	
		5) Telecommunications wires		✓	
		6) Rain water drain pipes		✓	
		7) Elevators		✓	
		8) Fire hydrant systems and sprinkler systems		✓	
		9) Air-conditioning, fire, and smoke exhaust ducts	Secondary	Primary	✓
ii)	Inside the building	1) Pipes carrying specialized fluids	Secondary	Primary	✓
		2) Fire hydrants piping system	Secondary	Primary	✓
		3) Other fluid piping systems	Secondary	Primary	✓
iii)	Storage vessels and water heaters	1) Flat bottomed containers and vessels	✓		
		2) Structurally supported vessels	✓		
iv)	Mechanical Equipment	1) Boilers and furnaces	✓		
		2) General manufacturing and process machinery	✓		
		3) HVAC equipment	✓		
		4) Overhead air handling units hung from ceiling	Primary	Secondary	✓
		5) Overhead air handling rested on brackets	✓		
		6) Lifts of all types	Secondary	Primary	✓
		7) Chutes of all types, including refuse (waste), and laundry	Primary	Secondary	✓

10.4 Earthquake Analysis

Unless stated otherwise, this standard requires the following:

- a) The design lateral force on the *A-AEU's* shall be estimated as per **10.5.1**. When the non-engineered or pre-engineered strategy is adopted to protect the *A-AEU*, no structural analysis is required of the structure on which the *A-AEU* is mounted

to estimate this design force. But, when the engineered strategy is adopted, the architect or the structural engineer may use results of nonlinear analysis of the structure to estimate the design lateral force; in such cases, the design lateral force so estimated shall not be taken less than that specified in **10.5.1**; and

- b) The design relative movement between the ends of the *D-AEU's* shall be estimated as

per **10.5.2**. No new structural analysis is required of the structure on which the *D-AEU* is mounted to estimate this design displacement. The results of the structural analysis already performed for the design or assessment of the structure shall be used.

10.5 Earthquake Demands on AEU

The *AEUs* and their connections to structural elements (*SEs*) shall be designed to resist the design lateral force and design relative displacement specified hereunder.

10.5.1 Acceleration-Sensitive AEU

The following shall be complied with:

10.5.1.1 All acceleration-sensitive *AEUs* (*A-AEUs*) shall be secured only to the *SEs* by positive anchorage:

- a) At as many locations on the *SEs* required to keep that *A-AEU* stable during earthquake shaking; and
- b) Only at locations of *SEs* that are not likely to form plastic hinges during earthquake shaking.

10.5.1.2 The design lateral force F_{AEU} for the design of such anchorages connecting *A-AEUs* to the *SEs* of the building shall be taken as:

$$F_{AEU} = \left[Z \left(1 + \frac{x}{H} \right) I_{AEU} \left(\frac{\alpha_{AEU}}{R_{AEU}} \right) \right] W_{AEU} \geq 0.04 W_{AEU}$$

where

- Z = earthquake zone factor as per **6.2.2.2**;
- x = height of the point of attachment of *A-AEU* above top of the foundation of the structure;
- I_{AEU} = importance factor of the *A-AEU* (see Table 11);
- α_{AEU} = acceleration amplification factor of the *A-AEU* (see Table 12 and Table 13);

W_{AEU} = weight of the *A-AEU*;

H = overall height of the structure above top of the foundation; and

R_{AEU} = elastic force reduction factor of the *A-AEU* (see Table 12 and Table 13).

When site-specific earthquake hazard assessment is performed for a building or structure, the value of Z shall be replaced by the normalised peak ground acceleration that is peak ground acceleration estimated at the site of the structure divided by acceleration due to gravity g .

10.5.1.3 The critical direction in which the design lateral force F_{AEU} on *AEU* should be applied need not be the principal orthogonal directions of the structural system (even if the structure is regular); it could be along directions other than the said principal orthogonal directions. In such cases, the design lateral force F_{AEU} on the *AEUs* shall be calculated along each principal orthogonal plan direction of the structure and combined as per **8.4.3** to estimate the force demands on the connections of these *A-AEUs* with the structure.

10.5.1.4 The requirements of **10.5.1.2** shall not be applicable for the design of infill walls and partition walls that are constructed integrally with no gap between the said walls and the structural elements; in such cases, the said infill walls and partition walls shall be considered as part of the structural elements. But these shall be applicable for the design of infill walls and partition walls that are constructed with a gap between the structural elements, so that these walls do not foul with the lateral movement of the structural elements; in such cases, it shall be ensured that the said infill walls and partition walls are held by suitable methods and prevented from toppling.

10.5.1.5 The design lateral force F_{AEU} on *AEU* shall be applied at the center of mass of the *AEU*.

10.5.1.6 The design lateral force F_{AEU} corresponds to the portion of the *A-AEUs* projecting beyond the point of lateral support.

Table 11 Importance Factor I_{AEU} of the A-AEUs

(Clause 10.5.1.2)

SI No.	Description of A-AEU	I_{AEU}
(1)	(2)	(3)
i)	AEU containing hazardous contents	2.5
ii)	AEUs whose collapse will harm the people and property either inside or outside the structure	2.5
iii)	AEU required to function after an earthquake (such as, a fire protection sprinkler system)	2.5
iv)	Storage rack AEUs in structures open to the public	2.5
v)	All other AEUs	2.0

Table 12 Acceleration Amplification Factor α_{AEU} and Elastic Force Reduction Factor R_{AEU} of Architectural A-AEUs

(Clause 10.5.1.2)

SI No.	Items	α_{AEU}	R_{AEU}
(1)	(2)	(3)	(4)
i)	Interior partition walls:		
	a) Unreinforced masonry walls in non-critical areas	1.0	1.5
	b) Other partition walls in critical areas	1.5	1.5
ii)	Cantilever elements, which are braced to SEs above their centre of mass, or unbraced:		
	a) Parapets and cantilever interior infill walls	2.5	2.5
	b) Chimneys and stacks which are laterally supported	2.5	2.5
iii)	Cantilever elements, which are braced to SEs below their centre of mass:		
	a) Parapets	1.0	2.5
	b) Chimneys and stacks	1.0	2.5
	c) Exterior infill walls	1.0	2.5
iv)	Exterior infill wall elements and connections:		
	a) Wall element	1.0	2.5
	b) Body of wall panel connection	1.0	2.5
	c) Fasteners of the connecting system	1.25	1.0
v)	Veneer:		
	a) High deformability elements and attachments	1.0	2.5
	b) Low deformability and attachments	1.0	1.5
vi)	Penthouses that are not made by extending the building frame	2.5	3.5
vii)	Ceilings	1.0	2.5
viii)	Storage cabinets and laboratory equipment	1.0	2.5
ix)	Access floors:		

SI No.	Items	α_{AEU}	R_{AEU}
(1)	(2)	(3)	(4)
	a) Special access floors	1.0	2.5
	b) Others	1.0	1.5
x)	Appendages and ornamentations	2.5	2.5
xi)	Signs boards and hoardings	2.5	2.5
xii)	Other AEU's with attachments:		
	a) Massive:		
	1) High deformability	1.0	3.5
	2) Limited deformability	1.0	2.5
	3) Low deformability	1.0	1.5
	b) Lineal:		
	1) High deformability	2.5	3.5
	2) Limited deformability	2.5	2.5
	3) Low deformability	2.5	1.5

Table 13 Acceleration Amplification Factor α_{AEU} and Elastic Force Reduction Factor R_{AEU} of Mechanical and Electrical Equipment A-AEU's

(Clause 10.5.1.2)

SI No.	Item	α_{AEU}	R_{AEU}
(1)	(2)	(3)	(4)
i)	General mechanical equipment:		
	a) Boilers and furnaces	1.0	2.5
	b) Pressure vessels (on edges and free-standing)	2.5	2.5
	c) Stacks	2.5	2.5
	d) Cantilevered chimneys	2.5	2.5
	e) Others	1.0	2.5
ii)	Manufacturing and process machinery:		
	a) General	1.0	2.5
	b) Conveyors (non-personnel)	2.5	2.5
iii)	Piping systems with attachments:		
	a) High deformability	1.0	2.5
	b) Limited deformability	1.0	2.5
	c) Low deformability	1.0	1.5
iv)	HVAC system equipment:		
	a) Vibration isolated	1.0	2.5
	b) Non-vibration isolated	2.5	2.5
	c) Mounted in-line with duct work	1.0	2.5

SI No.	Item	α_{AEU}	R_{AEU}
(1)	(2)	(3)	(4)
	d) Others	1.0	2.5
v)	Elevator with associated equipment	1.0	2.5
vi)	Escalator with associated equipment	1.0	2.5
vii)	Lighting fixtures	1.0	1.5
viii)	Trussed towers: free-standing or guyed	2.5	2.5
ix)	General electrical distributed systems (bus ducts, conduit, cable tray)	2.5	5.0
x)	General electrical equipment	1.0	1.5
xi)	Other vibration isolation equipment	1.0	2.5

10.5.2 Displacement-Sensitive AEU's

10.5.2.1 All displacement-sensitive AEU's (D-AEU's) supported by the SEs of:

- A structure, at different levels;
- Adjacent structures, at same level; and
- Adjacent structures, at different levels.

shall be designed to allow relative displacements imposed at their ends owing to the deformations in the SEs of the structure(s) arising from the design earthquake ground shaking at the base of the structure(s).

10.5.2.2 When this imposed relative displacement arises out of earthquake shaking, thermal conditions in the SEs and the D-AEU, imposed live loads, etc, the relative displacement imposed by each of these effects shall be cumulated to arrive at the design relative displacement Δ that is most unfavourable on the D-AEU.

10.5.2.3 The design relative displacement demands Δ_X , Δ_Y and Δ_Z imposed at the two ends of a D-AEU, when the structure(s) on which it is supported are subjected to load effects specified in **10.5.2.4**, shall be estimated as given hereunder:

- When supported consecutively at two levels of the same structure (Structure A), one at height h_1 and the other at height h_2 from base of the structure:

$$\Delta_X = R_A |\Delta_{XA1} - \Delta_{XA2}|$$

$$\Delta_Y = R_A |\Delta_{YA1} - \Delta_{YA2}|$$

$$\Delta_Z = R_A |\Delta_{ZA1} - \Delta_{ZA2}|$$

- When supported at:

- two levels of two different structures (A and B, say, even if one of them is an electric pole, or a communication antenna tower), or
- at two levels of two adjoining parts (A and B, say) of the same structure separated by a separation joint on which the D-AEU is supported, that is, at height h_1 on structure A and at height h_2 on structure B from bases of the respective structures:

$$\Delta_X = R_A |\Delta_{XA1}| + R_B |\Delta_{XB2}|$$

$$\Delta_Y = R_A |\Delta_{YA1}| + R_B |\Delta_{YB2}|$$

$$\Delta_Z = R_A |\Delta_{ZA1}| + R_B |\Delta_{ZB2}|$$

- When supported with one end at a level on a structure and another on adjoining ground,

$$\Delta_X = R_A |\Delta_{XA1}| + 1.2 |\Delta_{XG}|$$

$$\Delta_Y = R_A |\Delta_{YA1}| + 1.2 |\Delta_{YG}|$$

$$\Delta_Z = R_A |\Delta_{ZA1}| + 1.2 |\Delta_{ZG}|$$

where

Δ_{XA1} , Δ_{YA1} and Δ_{ZA1} = design displacements along X, Y and Z directions, respectively, of structure A at height h_1 at level 1 from its base, respectively;

Δ_{xA2} , Δ_{yA2} and Δ_{zA2} = design displacements along X, Y and Z directions, respectively, of structure A at height h_2 at level 2 from its base, respectively;

Δ_{xB2} , Δ_{yB2} and Δ_{zB2} = design displacements along X, Y and Z directions, respectively, of structure B at height h_2 at level 2 from its base, or of the ground, respectively;

R_A and R_B = elastic force reduction factors used in the design of structures A and B, respectively; and

Δ_{xG} and Δ_{yG} = design peak ground displacements along X and Y directions, respectively, at the site of the structure estimated as $D_H(T_H)$ as per **6.2.3.4** with T_H taken as zero, and

Δ_{zG} = design peak ground displacements along Z direction at the site of the structure estimated as $D_V(T_V)$ as per **6.2.3.4** with T_V taken as zero.

10.5.2.4 The design relative displacements demand Δ mentioned in **10.5.2.3** shall be determined by linear equivalent static analysis of the structure subjected to earthquake loads as per **8.3.3** to estimate the displacement demands to be accommodated at the supports of the *D-AEUs*.

ANNEX A

(Clause 2)

LIST OF REFERRED STANDARDS

<i>IS No.</i>	<i>Title</i>	<i>IS No.</i>	<i>Title</i>
IS 456 : 2000	Plain and reinforced concrete — Code of practice (<i>fourth revision</i>)	(Part 11) : XXXX	Tunnels (<i>under preparation</i>)
IS 800 : 2007	General construction in steel — Code of practice (<i>third revision</i>)	(Part 12) : XXXX	Earth-retaining structures (<i>under preparation</i>)
IS 875	Code of practice for design loads (other than earthquake) for buildings and structures — Code of practice:	IS 1904 : 2021	General requirements for design and construction of foundations in soils — Code of practice (<i>fourth revision</i>)
(Part 1) : 1987	Dead loads — Unit weights of building materials and stored materials (<i>second revision</i>)	IS 1905 : 1987	Code of practice for structural use of unreinforced masonry (<i>third revision</i>)
(Part 2) : 1987	Imposed loads (<i>second revision</i>)	IS 2809 : 1972	Glossary of terms and symbols relating to soil engineering (<i>first revision</i>)
(Part 3) : 2015	Wind loads (<i>third revision</i>)	IS 2810 : 1979	Glossary of terms relating to soil dynamics (<i>first revision</i>)
(Part 4) : 1987	Snow loads (<i>second revision</i>)	IS 8009 (Part 2) : 1980	Code of practice for calculation of settlement of foundations: Part 2 Deep foundations subjected to symmetrical static vertical loading
(Part 5) : 1987	Special loads and load combinations (<i>second revision</i>)	IS 13920	Earthquake-resistant design and detailing of structures — Code of practice:
IS 1343 : 2012	Prestressed concrete — Code of practice (<i>second revision</i>)	(Part 1) : 2025	General provisions
IS 1893	Design earthquake hazard and criteria for earthquake-resistant design of structures — Code of practice:	(Part 2) : XXXX	Liquid-retaining structures (<i>under preparation</i>)
(Part 2) : 2025	Liquid-retaining structures (<i>under preparation</i>)	(Part 3) : XXXX	Bridges (<i>under preparation</i>)
(Part 3) : 2025	Bridges (<i>under preparation</i>)	(Part 4) : XXXX	Industrial structures (<i>under preparation</i>)
(Part 4) : 2025	Industrial structures	(Part 5) : 2025	Buildings
(Part 5) : 2025	Buildings	(Part 6) : XXXX	Base-isolated buildings (<i>under preparation</i>)
(Part 6) : 2025	Base-isolated buildings	(Part 7) : XXXX	Long-distance pipelines (<i>under preparation</i>)
(Part 7) : 2025	Long-distance pipelines (<i>under preparation</i>)	(Part 8) : XXXX	Dams (<i>under preparation</i>)
(Part 8) : 2025	Dams (<i>under preparation</i>)	(Part 9) : XXXX	Steel towers (<i>under preparation</i>)
(Part 9) : XXXX	Steel towers (<i>under preparation</i>)	(Part 10) : XXXX	Costal structures (<i>under preparation</i>)
(Part 10) : XXXX	Costal structures (<i>under preparation</i>)		

<i>IS No.</i>	<i>Title</i>	<i>IS No.</i>	<i>Title</i>
(Part 9) : XXXX	Steel towers (<i>under preparation</i>)	(Part 5) : 2025	Buildings
(Part 10) : XXXX	Costal structures (<i>under preparation</i>)	(Part 6) : XXXX	Base-isolated buildings (<i>under preparation</i>)
(Part 11) : XXXX	Tunnels (<i>under preparation</i>)	(Part 7) : XXXX	Long-distance pipelines (<i>under preparation</i>)
(Part 12) : XXXX	Earth-retaining structures (<i>under preparation</i>)	(Part 8) : XXXX	Dams (<i>under preparation</i>)
IS 13935	Assessment and retrofit of structures for earthquake safety — Code of practice:	(Part 9) : XXXX	Steel towers (<i>under preparation</i>)
(Part 1) : 2025	General provisions	(Part 10) : XXXX	Costal structures (<i>under preparation</i>)
(Part 2) : XXXX	Liquid-retaining structures (<i>under preparation</i>)	(Part 11) : XXXX	Tunnels (<i>under preparation</i>)
(Part 3) : XXXX	Bridges (<i>under preparation</i>)	(Part 12) : XXXX	Earth-retaining structures (<i>under preparation</i>)
(Part 4) : XXXX	Industrial structures (<i>under preparation</i>)		

ANNEX B

(Foreword and Clause 3.18)

MSK 1964 INTENSITY SCALE

B-1 NOMENCLATURE

The following description shall be applicable for the words used in the intensity scale:

B-1.1 Type of Structures (Buildings)

<i>Type A</i>	Building in field-stone, rural structures, un-burnt brick houses, clay houses
<i>Type B</i>	Ordinary brick buildings, buildings of large block and prefabricated type, half-timbered structures, buildings in natural hewn stone
<i>Type C</i>	Reinforced buildings, well-built wooden structures

B-1.2 Definition of Quantity

Single, few	About 5 percent
Many	About 50 percent
Most	About 75 percent

B-1.3 Classification of Damage to Buildings

<i>Classification</i>	<i>Damage</i>	<i>Description</i>
Grade 1	Slight damage	Fine cracks in plaster; fall of small pieces of plaster
Grade 2	Moderate damage	Small cracks in walls; fall of larger pieces of plaster; pantiles slip off; cracks in chimneys parts; or chimney fall
Grade 3	Heavy damage	Large and deep cracks in walls; fall of chimneys
Grade 4	Destruction	Gaps in walls; parts of buildings may collapse; separate parts of the buildings lose their cohesion; and inner walls collapse
Grade 5	Total damage	Total collapse of the buildings

B-2 ARRANGEMENT OF THE MSK INTENSITY SCALE

B-2.1 Parameters of the Scale

The MSK intensity scale uses three parameters when describing the scale:

- Persons and surroundings;
- Structures of all kinds; and
- Nature.

<i>Intensity Level</i>	<i>Description</i>
(1)	(2)
i)	Not noticeable
a)	The intensity of the vibration is below the limits of sensibility; the tremor is detected and recorded by seismograph only.
b)	—
c)	—
ii)	Scarcely noticeable (very slight)
a)	Vibration is felt only by individual people at rest in houses, especially on upper floors of buildings.
b)	—
c)	—
iii)	Weak, partially observed
a)	The earthquake is felt indoors by a few people, outdoors only in favourable circumstances. The vibration is like that due to the passing of a light truck. Attentive observers notice a slight swinging of hanging objects.
b)	—
c)	—
iv)	Largely observed
a)	The earthquake is felt indoors by many people, outdoors by few. Here and there people awake, but no one is frightened. The vibration is like that due to the passing of a heavily loaded truck. Windows, doors, and dishes rattle. Floors and walls crack. Furniture begins to shake. Hanging objects swing slightly. Liquid in open vessels is slightly disturbed. In standing motor cars the shock is noticeable.
b)	—
c)	—
v)	Awakening
a)	The earthquake is felt indoors by all, outdoors by many. Many people awake, and a few run outdoors. Animals become uneasy. Buildings tremble throughout. Hanging objects swing considerably. Pictures knock against walls or swing out of place. Occasionally pendulum clocks stop. Unstable objects overturn or shift. Open doors and windows are thrust open and slam back again. Liquids spill in small amounts from well-filled open containers. The sensation of vibration is like that due to heavy objects falling inside the buildings.
b)	Slight damage in buildings of Type A are possible.
c)	Slight waves on standing water. Sometimes changes in flow of springs.

Intensity Level	Description
vi)	Frightening
	<p>a) Felt by most indoors and outdoors.</p> <p>Many people in buildings are frightened and run outdoors.</p> <p>A few persons lose their balance.</p> <p>Domestic animals run out of their stalls.</p> <p>In a few instances, dishes and glassware may break, and books fall down, pictures move, and unstable objects overturn.</p> <p>Heavy furniture may possibly move and small steeple bells may ring.</p>
	<p>b) Damage of Grade 1 is sustained in single buildings of Type B and in many of Type A.</p> <p>Damage in some buildings of Type A is of Grade 2.</p>
	<p>c) Cracks up to widths of 1 cm form in wet ground.</p> <p>In the mountains, occasional landslides, and changes observed in the flow of springs and in level of well water.</p>
vii)	Damage of Buildings
	<p>a) Most people are frightened and run outdoors.</p> <p>Many find it difficult to stand.</p> <p>The vibration is noticed by persons driving motor cars.</p> <p>Large bells ring.</p>
	<p>b) In many buildings of Type C damage of Grade 1 is caused.</p> <p>In many buildings of Type B damage is of Grade 2.</p> <p>Most buildings of Type A suffer damage of Grade 3, few of Grade 4.</p>
	<p>c) In single instances, landslides of roadway on steep slopes, cracks in roads, seams of pipelines damaged, and cracks in stone walls.</p> <p>Waves are formed on water, and water is made turbid by mud stirred up.</p> <p>Water levels in wells change, and the flow of springs changes.</p> <p>Sometimes dry springs have their flow restored and existing springs stop flowing.</p> <p>In isolated instances parts of sand and gravelly banks slip off.</p>
viii)	Destruction of Buildings
	<p>a) Fright and panic.</p> <p>Also, persons driving motor cars are disturbed.</p> <p>Here and there branches of trees break off.</p> <p>Even heavy furniture moves and partly overturns.</p> <p>Hanging lamps are damaged in part.</p>

-
- b) Most buildings of Type C suffer damage of Grade 2, and few of Grade 3.
Most buildings of Type B suffer damage of Grade 3.
Most buildings of Type A suffer damage of Grade 4.
Occasional breaking of pipe seams.
Memorials and monuments move and twist. Tombstones overturn.
Stone walls collapse.
-

- c) Small landslips in hollows and on banked roads on steep slopes.
Cracks in ground up to widths of several centimetres.
Water in lakes become turbid.
New reservoirs come into existence.
Dry wells refill and existing wells become dry.
In many cases, change in flow and level of water is observed.
-

ix) **General Damage of Buildings**

- a) General panic; considerable damage to furniture.
Animals run to and fro in confusion and cry.
-

- b) Many buildings of Type C suffer damage of Grade 3, and a few of Grade 4.
Many buildings of Type B exhibit damage of Grade 4 and a few of Grade 5.
Many buildings of Type A suffer damage of Grade 5.
Monuments and columns fall.
Considerable damage to reservoirs; underground pipes partly broken.
In individual cases, railway lines are bent and the roadway is damaged.
-

- c) On flat land overflow of water, sand and mud is often observed.
Ground cracks to widths of up to 10 cm, on slopes and river banks more than 10 cm.
Many slight cracks in the ground.
Falls of rock.
Many landslides and earthflows.
Large waves in water.
Dry wells renew their flow and existing wells dry up.
-

x) **General Destruction of Buildings**

- a) —
-

- b) Many buildings of Type C suffer damage of Grade 4, and a few of Grade 5.
Many buildings of Type B show damage of Grade 5.
Most of Type A has destruction of Grade 5.
Critical damage to dykes and dams.
Severe damage to bridges.
Railway lines are bent slightly.
Underground pipes are bent or broken.
Road paving and asphalt show waves.
-

-
- c) In the ground, cracks up to widths of several centimetres; sometimes up to 1 m parallel to water courses occur broad fissures.

Loose ground slides from steep slopes.

From river banks and steep coasts, considerable landslides are possible.

In coastal areas, displacement of sand and mud; change of water level in wells; and water from canals, lakes, rivers, etc, thrown on land.

New lakes occur.

xi) Destruction

- a) —

-
- b) Severe damage even to well-built buildings, bridges, water dams and railway lines.

Highways become useless.

Underground pipes destroyed.

-
- c) Ground considerably distorted by broad cracks and fissures, as well as movement in horizontal and vertical directions.

Numerous landslips and falls of rocks.

The intensity of the earthquake requires to be investigated specifically.

xii) Landscape Changes

- a) —

-
- b) Practically all structures above and below ground are greatly damaged or destroyed.

-
- c) The surface of the ground is radically changed.

Considerable ground cracks with extensive vertical and horizontal movements are observed.

Falling of rock and slumping of river banks over wide areas, lakes are dammed.

Waterfalls appear and rivers are deflected.

The intensity of the earthquake requires to be investigated specially.

ANNEX C

(Foreword)

EARTHQUAKE HAZARD ASSESSMENT FOR MACRO-ZONING AND SITE-SPECIFIC STUDIES

C-1 TWO LEVELS OF ASSESSMENT

Traditionally, the state-of-the-art probabilistic earthquake hazard assessment (PEHA) method was employed to arrive at the site-specific hazard assessment at important project sites. In this standard:

- a) PEHA has been utilized with some generalization for macro-zoning of India, and thereby, to arrive at the earthquake zone map; and
- b) PEHA is recommended with minor improvements for site-specific earthquake hazard assessment, as specified hereunder.

C-2 EARTHQUAKE HAZARD AT BEDROCK

The following inputs are considered in estimating the earthquake hazard (in terms of PGA and shape of PSA spectrum):

- a) Macro-hazard assessment is performed at the engineering bedrock condition characterized by V_{S30} value of 760 m/s; and
- b) Site-specific hazard assessment should be obtained directly for V_{S30} (m/s) obtained experimentally at the site and the actual local geological condition defined in terms of $Z_{1.0}$, $Z_{2.5}$ or qualitatively (rock, deep soil or intermediate) as per the ground motion prediction equations (GMPEs) used. Here, $Z_{1.0}$ and $Z_{2.5}$ are the depths to the stratum that have a shear wave velocity of 1.0 km/s and 2.5 km/s, respectively.

C-2.1 Faults

- a) *Macro-hazard assessment* — Surface traces of major faults as identified in the seismotectonics atlas of India (*GSI*) are considered along with the additions from published literature for areas outside the Indian territory (*see* Fig. 8); and
- b) *Site-specific hazard assessment* — To the extent possible, additional faults (from the literature survey) of localized nature within 50 km, analysis of satellite imageries and field studies are considered in the analysis.

C-2.2 Seismicity Catalogue

A comprehensive seismicity catalogue covering the period of about past 600 years (up to 2019) was

compiled (covering historical, early instrumental, and modern instrumental periods) from various authentic published sources from within India and abroad (*see* Fig. 9). The catalogue contains information on date, time, location (latitude and longitude), focal depth and different types of magnitude for each event. The catalogue has been scrutinized for quality and duplicate events and processed for homogenization in terms of moment magnitude and de-clustered in this hazard assessment.

C-2.3 Seismogenic Source Areas

- a) *Macro-hazard assessment* — The Indian landmass and its adjoining areas are considered to comprise of 33 large size seismogenic source areas based on seismotectonic features, past seismicity, geological formations, and other geophysical characteristics, where each source region represents an area of distinctly different seismic potential and frequency of earthquakes. In general, source areas have irregular shapes with their boundaries defined by geographical coordinates; and
- b) *Site-specific hazard assessment* — Much smaller size of source areas is recommended to be used within an area of at least $6^\circ \times 6^\circ$ centred approximately at the site. In addition, fault-specific line and dipping-surface types of sources should be used in combination with the area type sources to the extent possible.

C-2.4 Ground Motion Prediction Equations

Region-specific sets of GMPEs for different seismotectonic regions (for example, active crustal region, stable continental region and subduction zone region) of the country were developed or selected using data-driven methods based on available strong motion data for estimation of earthquake hazard. These were used in a logic tree framework with appropriate weights to account for the epistemic uncertainties. The different sets of GMPEs were used for the four regions of the country (namely Himalaya, Indo-Gangetic Plains, Peninsular India, and Subduction Zone Regions) (*see* Table 14). Updated and region-specific GMPEs are recommended to be used, if justified on technical grounds.

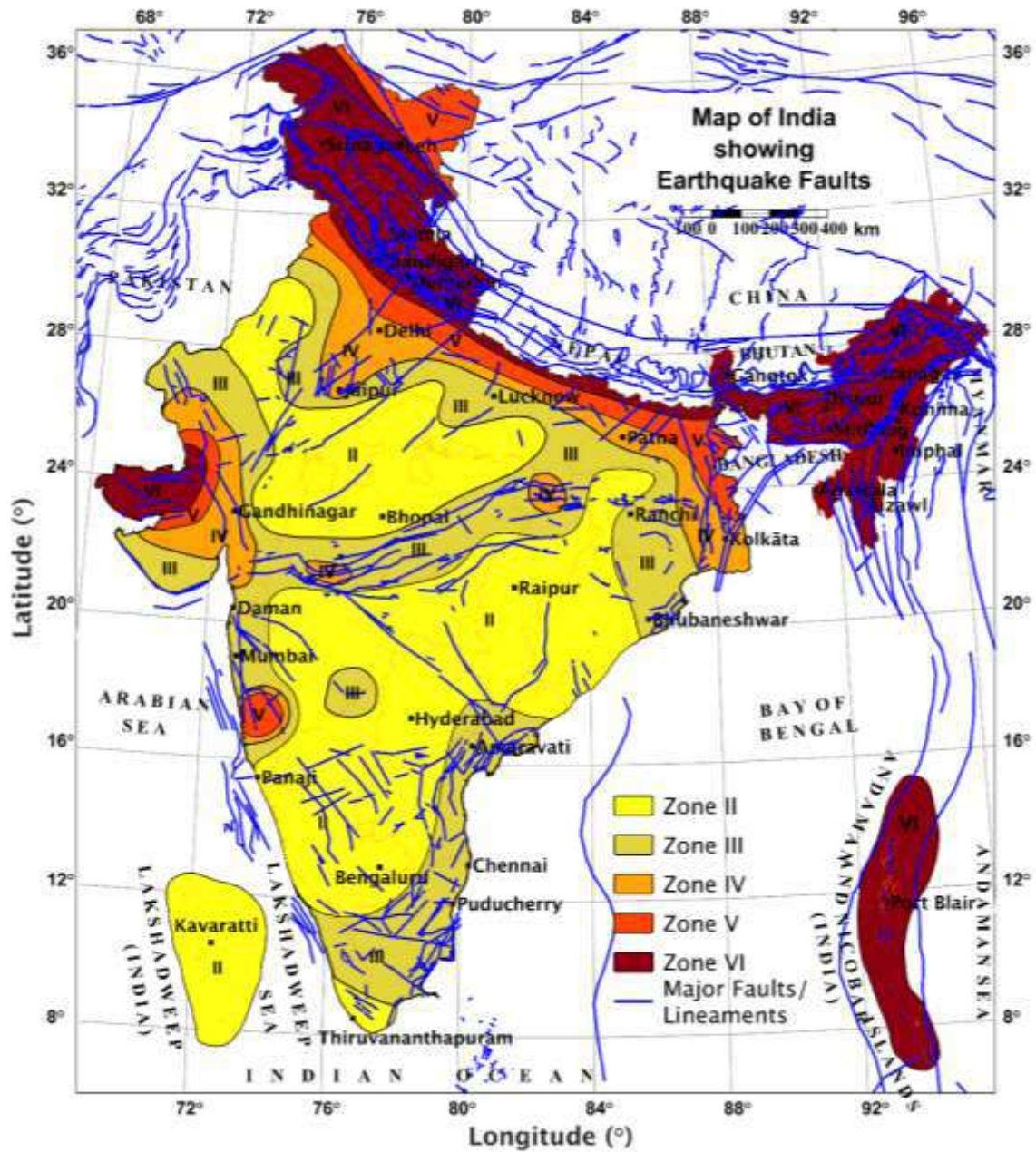

NOTES

- 1 This map is based upon Survey of India Political map printed in 2002.
- 2 The territorial waters of India extend into the sea to twelve nautical from the appropriate baseline.
- 3 The interstate boundaries between Arunachal Pradesh, Assam and Meghalaya shown on this map are as interpreted from the *North-Eastern Areas (Reorganization) Act, 1971*, but have yet to be verified.
- 4 The state boundaries between Uttarakhand and Uttar Pradesh, Bihar and Jharkhand, and Chhattisgarh and Madhya Pradesh have not been verified by the Governments concerned.
- 5 The administrative headquarters of Chandigarh, Haryana and Punjab are at Chandigarh.
- 6 The responsibility for the correctness of internal rests with the publisher.
- 7 For details regarding the up-to-date seismic activity (plotted on the Map of India), please visit the online portal of the National Centre for Seismology (NCS), Ministry of Earth Sciences, New Delhi.

FIG. 8 MAP OF INDIA SHOWING PRINCIPAL TECTONIC FAULTS CONSIDERED IN EARTHQUAKE HAZARD ASSESSMENT

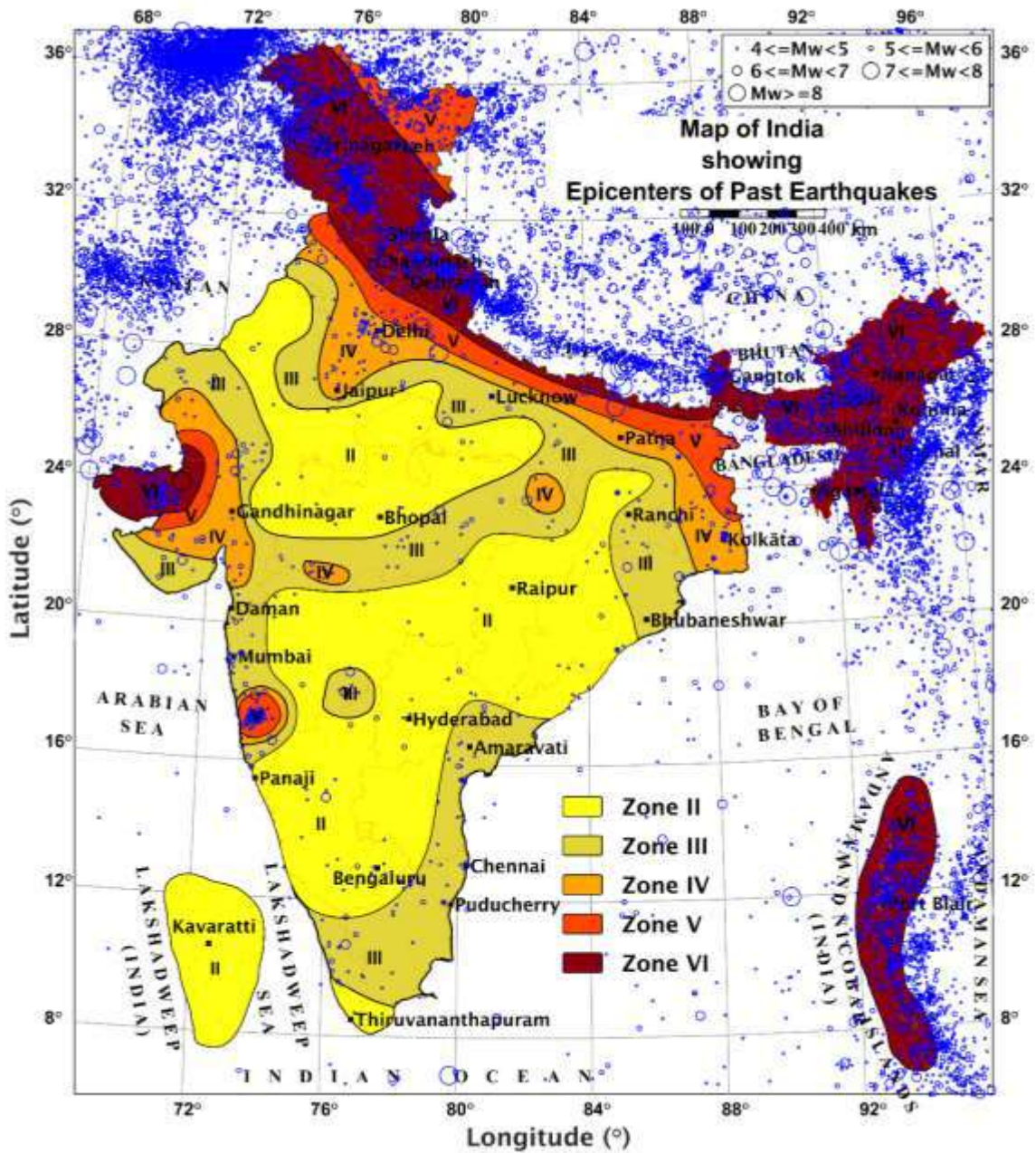

NOTES

- 1 This map is based upon Survey of India Political map printed in 2002.
- 2 The territorial waters of India extend into the sea to twelve nautical from the appropriate baseline.
- 3 The interstate boundaries between Arunachal Pradesh, Assam and Meghalaya shown on this map are as interpreted from the *North-Eastern Areas (Reorganization) Act, 1971*, but have yet to be verified.
- 4 The state boundaries between Uttarakhand and Uttar Pradesh, Bihar and Jharkhand, and Chhattisgarh and Madhya Pradesh have not been verified by the Governments concerned.
- 5 The administrative headquarters of Chandigarh, Haryana and Punjab are at Chandigarh.
- 6 The responsibility for the correctness of internal rests with the publisher.
- 7 For details regarding the up-to-date seismic activity (plotted on the Map of India), Please visit the online portal of the National Centre for Seismology (NCS), Ministry of Earth Sciences, New Delhi.

FIG. 9 MAP OF INDIA SHOWING EPICENTERS OF PAST EARTHQUAKES IN INDIA CONSIDERED IN EARTHQUAKE HAZARD ASSESSMENT

Table 14 List of GMPEs for Site-Specific Probabilistic Earthquake Hazard Assessment

(Clause C-2.4)

SI No.	GMPE	Weight	Reference
(1)	(2)	(3)	(4)
i)	Himalayan Region		
a)	BSSA 2014	0.155	Boore,D.M., Stewart,J.P., Seyhan,E., and Atkinson,G.M., NGA-West2 equations for predicting PGA, PGV, and 5 percent damped PSA for shallow crustal earthquakes, <i>Earthquake Spectra</i> , 2014;30(3) : 1057–85
b)	CB 2014	0.168	Campbell,K.W., and Bozorgnia,Y., NGA-West2 ground motion model for the average horizontal components of PGA, PGV, and 5 percent damped linear acceleration response spectra, <i>Earthquake Spectra</i> , 2014;30(3) : 1087–115
c)	CY 2014	0.139	Chiou,B.S.J., and Youngs,R.R., Update of the Chiou and Youngs NGA model for the average horizontal component of peak ground motion and response spectra, <i>Earthquake Spectra</i> , 2014;30(3) : 1117–53
d)	ASK 2014	0.149	Abrahamson, N.A., Silva,W.J., and Kamai,R., Summary of the ASK14 ground motion relation for active crustal regions, <i>Earthquake Spectra</i> , 2014;30(3) : 1025–55
e)	GT 2018	0.215	Gupta,I.D., and Trifunac,M.D., Attenuation of strong earthquake ground motion–Dependence on geology along the wave path from the Hindukush subduction to western Himalaya, <i>Soil Dynamics and Earthquake Engineering</i> 2018; 114 : 127–46
f)	DR 2019	0.174	Dhanya,J., and Raghukanth,S.T.G., Neural network-based hybrid ground motion prediction equations for western Himalayas and north-eastern India, <i>Acta Geophysics</i> 2020;68(2) : 303–24
ii)	Indo-Gangetic Plains		
a)	SSSA 2017	0.227	Singh,S., Srinagesh,D., Srinivas,D., Arroyo,D., Perez-Campos,X., Chadha,R., Suresh,G., and Suresh,G., Strong ground motion in the Indo-Gangetic plains during the 2015 Gorkha, Nepal, earthquake sequence and its prediction during future earthquakes, <i>Bulletin Seismological Society of America</i> , 2017;107(3):1293–306
b)	BSSA 2014	0.166	Boore,D.M., Stewart,J.P., Seyhan,E., and Atkinson,G.M., NGA-West2 equations for predicting PGA, PGV, and 5% damped PSA for shallow crustal earthquakes. <i>Earthquake Spectra</i> , 2014;30(3) : 1057–85
c)	CY 2014	0.155	Chiou,B.S.J., and Youngs,R.R., Update of the Chiou and Youngs NGA model for the average horizontal component of peak ground motion and response spectra, <i>Earthquake Spectra</i> , 2014;30(3) : 1117–53
d)	ASK 2014	0.161	Abrahamson,N.A., Silva,W.J., and Kamai,R., Summary of the ASK14 ground motion relation for active crustal regions, <i>Earthquake Spectra</i> , 2014;30(3) : 1025–55
e)	CB 2014	0.291	Campbell,K.W., and Bozorgnia,Y., NGA-West2 ground motion model for the average horizontal components of PGA, PGV, and 5 percent damped linear acceleration response spectra, <i>Earthquake Spectra</i> , 2014; 30(3) : 1087–115
iii)	Peninsular India		
a)	NGA East model	0.5	Goulet,C.A., Bozorgnia,Y., Kuehn,N., Al Atik,L., Youngs,R.R., Graves,R.W., and Atkinson,G.M., NGA-East ground-motion characterization model Part I: summary of products and model

SI No.	GMPE	Weight	Reference
(1)	(2)	(3)	(4)
			development, <i>Earthquake Spectra</i> , 2021;37(1_suppl):1231–82
b)	AB 2006	0.5	Atkinson,G.M., and Boore,D.M., Earthquake ground-motion prediction equations for Eastern North America, <i>Bulletin Seismological Society of America</i> , 2006;96(6):2181–205
iv)	Subduction Zone Region		
a)	Zhao 2006	0.231	Zhao,J.X., Zhang,J., Asano,A., Ohno,Y., Oouchi,T., Takahashi,T., Ogawa,H., Irikura,K., Thio,H.K., and Somerville,P.G., Attenuation relations of strong ground motion in Japan using site classification based on predominant period, <i>Bulletin Seismological Society of America</i> , 2006;96(3) : 898–913
b)	Kanno 2006	0.152	Kanno,T., Narita,A., Morikawa,N., Fujiwara,H., and Fukushima,Y., A new attenuation relation for strong ground motion in Japan based on recorded data, <i>Bulletin Seismological Society of America</i> , 2006;96(3) : 879–97
c)	AB 2003	0.124	Atkinson,G.M., and Boore,D.M., Empirical ground-motion relations for subduction-zone earthquakes and their application to Cascadia and other regions, <i>Bulletin Seismological Society of America</i> , 2003; 93(4) : 1703–29
d)	BC Hydro 2016	0.271	Abrahamson,N., Gregor,N., and Addo,K., BC Hydro ground motion prediction equations for subduction earthquakes, <i>Earthquake Spectra</i> , 2016;32(1) : 23–44
e)	Youngs 1997	0.222	Youngs,R.R., Chiou,S.J., Silva,W.J., and Humphrey,J.R., Strong ground motion attenuation relationships for subduction zone earthquakes, <i>Seismological Research Letters</i> , 1997; 68(1) : 58–73

C-2.5 Recurrence Relation for Each Source Zone

C-2.5.1 Macro-Hazard Assessment

To assess the expected occurrence rates of different magnitudes of earthquakes in each source zone, the data from the aforementioned earthquake catalogue (within the source zone) are analysed for the completeness periods and utilized to define a recurrence model for the source zone in terms of the Gutenberg-Richter parameters ‘a’ and ‘b’ or equivalently parameters $\lambda (M_0)$ and $\beta = b \ln_{10}$ along

with the expected maximum magnitude M_{\max} (see Fig. 10 and Table 15). Randomness in earthquake magnitude and in M_{\max} has been accounted for estimating the occurrence rates.

C-2.5.2 Site-Specific Hazard Assessment

Recurrence models for area sources are recommended to be estimated in a similar way, but slip-rate data are required to be used to define the recurrence model for fault-specific sources.

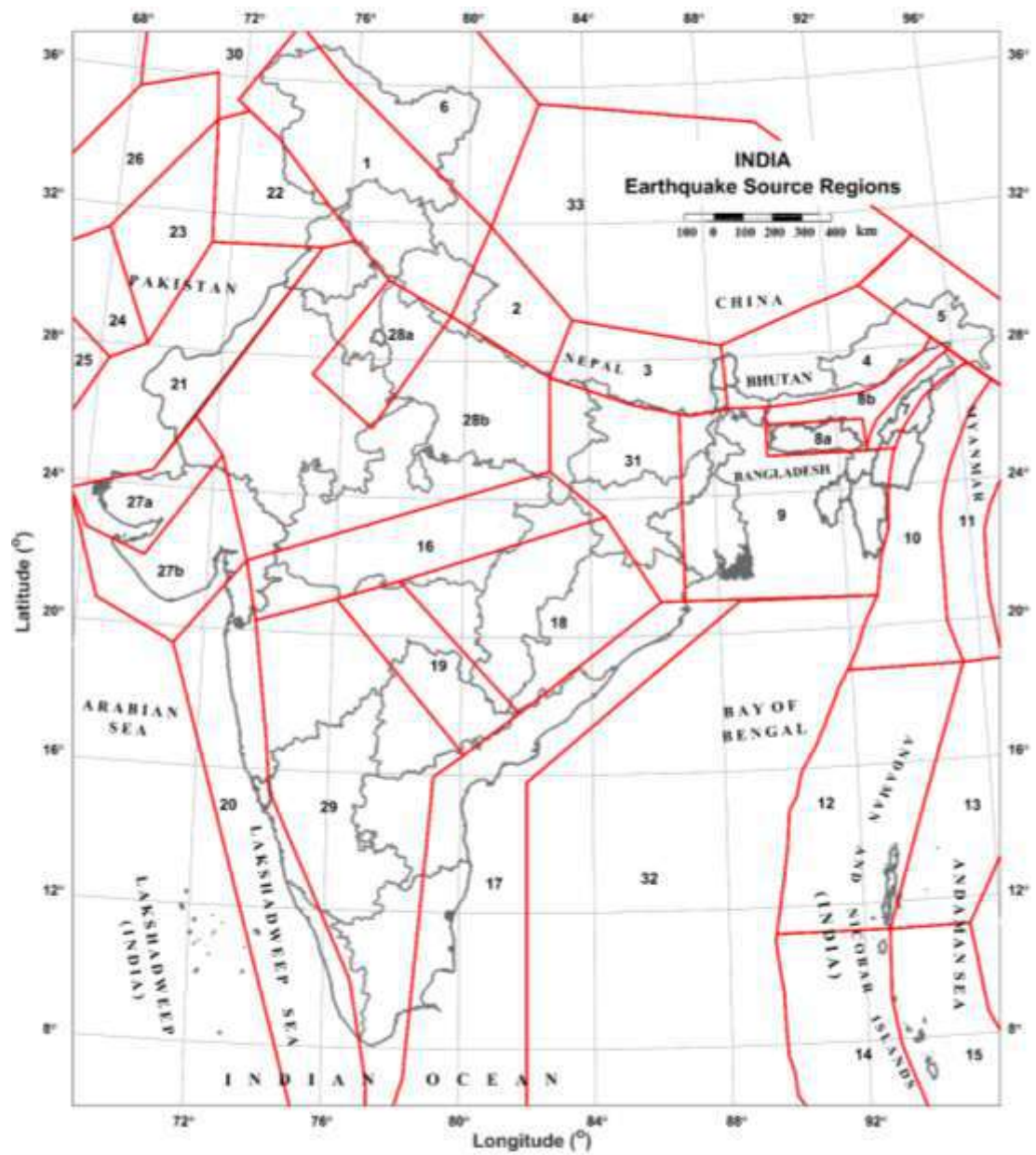

FIG. 10 MAP OF INDIA AND ADJOINING REGIONS SHOWING THE 33 SEISMOGENIC SOURCE AREAS CONSIDERED IN EARTHQUAKE HAZARD ASSESSMENT

Table 15 Maximum Magnitudes at Each Site in Earthquake Hazard Assessment Potential Depending on the Seismogenic Region in Which the Site is Located

(Clause C-2.5.1)

SI No.	Seismogenic Region	Magnitude (M_{max})	
		PEHA	DEHA
(1)	(2)	(3)	(4)
i)	Western Himalaya	8.3	6.5
ii)	Central Himalaya I	8.3	6.5
iii)	Central Himalaya II	8.3	6.5
iv)	Eastern Himalaya	8.3	6.5
v)	Mishmi Block	8.6	6.5
vi)	Altya Tegh and Karakoram	7.5	6.5
vii)	Naga Thrust	6.8	6.0
viii)	Excluding Shillong Plateau	8.0	6.0
ix)	Excluding Shillong Plateau Part	6.5	6.5
x)	Bengal Basin	7.8	6.5
xi)	Indo-Burmese Arc	7.8	6.5
xii)	Shan-Sagaing Fault	8.3	7.0
xiii)	West Andaman I	8.2	6.5
xiv)	East Andaman I	7.0	6.5
xv)	West Andaman II	8.2	6.5
xvi)	East Andaman II	7.3	6.5
xvii)	SONATA	6.6	5.0
xviii)	Eastern Passive Margin	6.4	5.0
xix)	Mahanandi Graben and Eastern Craton	6.0	5.0
xx)	Godavari Graben	6.3	5.0
xxi)	Western Passive Margin North of ~16° N	6.5	5.5
xxii)	Western Passive Margin South of ~16° N	6.5	5.0
xxiii)	Sindh-Punjab	6.5	5.0
xxiv)	Upper Punjab	7.8	6.5
xxv)	Koh-e-Sulaiman	8.0	6.5
xxvi)	Quetta-Sibi	8.0	6.5
xxvii)	Southern Baluchistan	8.0	6.5
xxviii)	Eastern Afghanistan	7.8	6.5
xxix)	Kutch Region of Gujarat	8.2	5.0
xxx)	Gujarat excluding Kutch Region	6.3	6.0

SI No.	Seismogenic Region	Magnitude (M_{max})	
		PEHA	DEHA
(1)	(2)	(3)	(4)
xxxix)	Delhi Fold Belt part of Aravali-Bundelkhand Region	6.6	5.0
xxxixii)	Aravali-Bundelkhand Region excluding Delhi Fold Belt part	6.3	5.5
xxxixiii)	Southern Craton	6.3	5.0
xxxixiv)	Hindukush and Pamirs	8.3	7.0
xxxixv)	Gangetic region North of 25°N	6.8	6.5
xxxixvi)	Gangetic region South of 25°N	6.8	5.0
xxxixvii)	Bay of Bengal	6.6	6.0
xxxixviii)	Tibet region	8.0	6.5

C-2.6 Source Mechanism Parameters and Focal Depth

The direction of fault strike is required for realistic spatial distribution of the earthquake occurrence rates over a source region, and the angle of dip, style of faulting and focal depth are required additionally for estimation of the various distance metrics involved in the GMPEs. All these parameters have been approximated by their dominant estimates for each source region considered as one unit.

C-2.7 Probabilistic Hazard Assessment

The earthquake hazard assessment is computed at a grid spacing of $0.1^\circ \times 0.1^\circ$ (in both latitude and longitude) by defining the seismicity for the same grid spacing. The state-of-the-art PEHA method was utilized with the site-specific inputs described above by accounting for the epistemic uncertainties in the various inputs by considering all plausible options with suitable weight factors in the logic tree framework. This has helped in normalisation of the subjectivity in defining the inputs. The earthquake hazard is computed in terms of response spectral amplitudes (corresponding to 5 percent damping ratio) at different natural periods corresponding to a return period of 2 475 years (that is 2 percent probability of exceedance in 50 years).

C-2.8 Deterministic Hazard Assessment

C-2.8.1 Macro-Hazard Assessment

Owing to lack of recorded past seismicity in some of the localized areas, the probabilistic hazard estimates were found to be unrealistically small. Therefore, in view of achieving adequate safety in structures, a lower bound to the probabilistic

earthquake hazard is worked out by introducing a novel application of the deterministic approach by defining a maximum frequent earthquake (MFE) magnitude for each source region (*see* Table 15). This is the magnitude that can be accepted to occur anytime on any of the mapped faults in a source region and is arrived at by expert elicitation.

The deterministic lower bound of hazard at each $0.1^\circ \times 0.1^\circ$ grid location is estimated by assuming the MFE magnitude for the corresponding source region to occur at the shortest possible distance on the nearest mapped fault to the grid point or at 25 km when the nearest fault happens to be at longer distance. The magnitude and distance pair thus arrived at for each grid location is used to estimate the hazard (mean + one standard deviation) using weighted average of the same set of GMPEs as used in the logic tree for the probabilistic estimate. Where the deterministic estimate was found to be higher than the probabilistic estimate, it is used as the final earthquake hazard. These estimates are estimated for class B soil strata (classification as per NEHRP), which is called commonly as the engineering bedrock.

C-2.8.2 Site-Specific Hazard Assessment

The deterministic hazard estimation should be implemented in the traditional way by defining the maximum credible earthquake (MCE) magnitude for each capable fault around the site, without any consideration for its recurrence interval and assuming it to occur at the minimum possible distance permitted by the fault geometry. The floating earthquake approach may be used when no potentially active fault is known to exist within 300 km of the site. The deterministic estimate (mean + one standard deviation) is then obtained for MCE

magnitude and distance combination expected to produce the most severe ground motion (arias intensity, cumulative absolute velocity (CAV), spectral intensities, spectral amplitude at a specified natural period, etc) for the structure at the site or any application (for example, liquefaction, or landslide). The final site-specific hazard shall be obtained from a critical comparison of the probabilistic and deterministic estimates as the higher or weighted average of the estimates from both the methods.

C-3 EARTHQUAKE ZONING OF INDIA

The final hazard estimates in terms of peak ground acceleration (PGA) obtained as above at the grid points covering the entire Indian landmass (corresponding to engineering bedrock) are modified to account for the amplification due to different site conditions defined approximately from lithological formations in different regions of the country. Based on one-dimensional site response analysis for an ensemble of velocity models obtained by scaling and randomization of selected actual models, which are representative for different lithological formations (*see* Fig. 11), the following factors are considered to amplify the PGA obtained at the assumed engineering bedrock from PEHA in regions with different lithological groups:

- | | | |
|----------------------------------|---|------|
| a) Metamorphic and igneous rocks | : | 1.00 |
| b) Sedimentary rocks | : | 1.15 |
| c) Laterite layers | : | 1.35 |
| d) Alluvium | : | 1.50 |

The resulting PGA hazard values were utilized to prepare a contour map, with five levels of peak ground acceleration (PGA) as ≤ 0.15 g, 0.15 g to 0.25 g, 0.25 g to 0.35 g, 0.35 g to 0.50 g and ≥ 0.50 g. These represent the five different earthquake zones, designated as earthquake Zones II, III, IV, V and VI. Due to high resolution used in preparing the earthquake zone map, the boundaries are found to be somewhat irregular in certain areas, which is undesirable for practical use of a zone map. Therefore, it was smoothed statistically. Each earthquake zone was characterized by the upper bound of the range utilized to demarcate the zones. The final earthquake zone factors is assigned as: 0.15 g, 0.25 g, 0.35 g, 0.50 g and 0.75 g, corresponding to earthquake Zones II, III, IV, V and VI, respectively. These values correspond to a return period of 2 475 years.

C-4 DESIGN PEAK GROUND ACCELERATION VALUES FOR DIFFERENT STRUCTURES

C-4.1 Macro-Hazard Assessment

After a detailed analysis, an empirical expression is developed to estimate the zone factor for different return periods from the reference PGA value corresponding to the reference return period $T_{R,ref}$ of 2 475 years. The PGA values are estimated in 5 categories of structures for the earthquake-resistant design of new structures or earthquake safety assessment of existing structures. These are the normal, important, critical, special and dams and associated structures to be designed for return periods of 475, 975, 2 475, 4 995 and user-specified return periods, respectively.

C-4.2 Site-Specific Hazard Assessment

The site-specific earthquake hazard should be derived for a return period of 2 475 years or more. The multiplication factors specified in Table 16 shall be used when estimating site-specific earthquake PGA values for other return periods.

C-5 DESIGN PSEUDO-SPECTRAL ACCELERATION

C-5.1 Macro-Hazard Assessment

A comprehensive analysis was carried out to arrive at the response spectral shapes specific to each zone corresponding to site Class B. To consider the effect of flexibility of the underlying soil on the response spectrum, the soil is classified into five types (in line with NEHRP classification) as specified in Table 17.

The same spectrum is specified for site Classes A and B, and no spectrum is specified for site Class E. Separate corner periods are specified for each of these groups to reflect the effect of flexibility of soil on the PSA spectrum.

For other site classes, different corner periods were suggested. But, the variation in these spectral shapes was found to be insignificant. A single uniform hazard PSA response spectrum was proposed for the entire country corresponding to 5 percent damping. Based on the physical considerations and the recorded data, the spectral shape was known to be dependent on the site soil conditions.

The design spectra provided in this standard are broadened to cover a range of natural periods (0 s to 10 s) of all structures of interest. Thus, for use in dynamic response history analysis, it is essential to select recorded ground motions, representing low, intermediate, and long period ranges of natural periods. The accelerograms should be scaled by suitable factors (in the range 0.5 to 2.0) to match the un-broadened design spectral shape in the respective period range as closely as possible (within 10 percent variation of the average spectra of the selected accelerograms). The ground motions to be used are described in [Annex E](#).

C-5.2 Site-Specific Earthquake Hazard Assessment

The site-specific hazard analysis provides directly the design response spectra of horizontal and vertical components of motion corresponding to 5 percent damping in terms of the actual absolute amplitudes at all natural periods. These are used to generate uncorrelated sets of compatible design acceleration time-histories synthetically or by modifying the suitably selected recorded accelerograms. Smoothed design response spectra for other desired

damping values should be computed directly from the design accelerograms obtained above. For use in dynamic response history analysis, the site-specific design response spectrum and associated design accelerograms shall be used with respect to the spectra given in this standard, along with the lower bound specified therein. But, the equivalent static method of analysis and design shall be governed solely by the provisions of this standard.

Table 16 Multiplying Factor to Estimate Site-Specific PGA for other Return Periods T_R in Terms of those for 2 475 Years

(Clause C-4.2)

Sl No.	Earthquake Zone	Multiplying Factor for Estimating Site-Specific PGA for Different Return Periods T_R (years)								
		75	175	275	475	975	1 275	2 475	4 975	9 975
(1)	(2)	(3)	(4)	(5)	(6)	(7)	(8)	(9)	(10)	(11)
i)	VI	2/5	1/2	3/5	2/3	4/5	5/6	1.0	5/4	6/4
ii)	V	2/5	1/2	3/5	2/3	4/5	5/6	1.0	5/4	6/4
iii)	IV	2/5	1/2	3/5	2/3	4/5	5/6	1.0	5/4	6/4
iv)	III	1/4	1/3	2/5	1/2	2/3	3/4	1.0	4/3	5.4/3
v)	II	1/4	1/3	2/5	1/2	2/3	3/4	1.0	4/3	5.4/3

Table 17 Weighted Average Shear Wave Velocity Demarcating the Soil Site Classes

(Clause C-5.1)

Sl No.	Site Class	Weighted Average Shear Wave Velocity V_S (m/s)
(1)	(2)	(3)
i)	A	$1\ 500 \leq V_S$
ii)	B	$760 \leq V_S < 1\ 500$
iii)	C	$360 \leq V_S < 760$
iv)	D	$180 < V_S < 360$
v)	E	$V_S \leq 180$

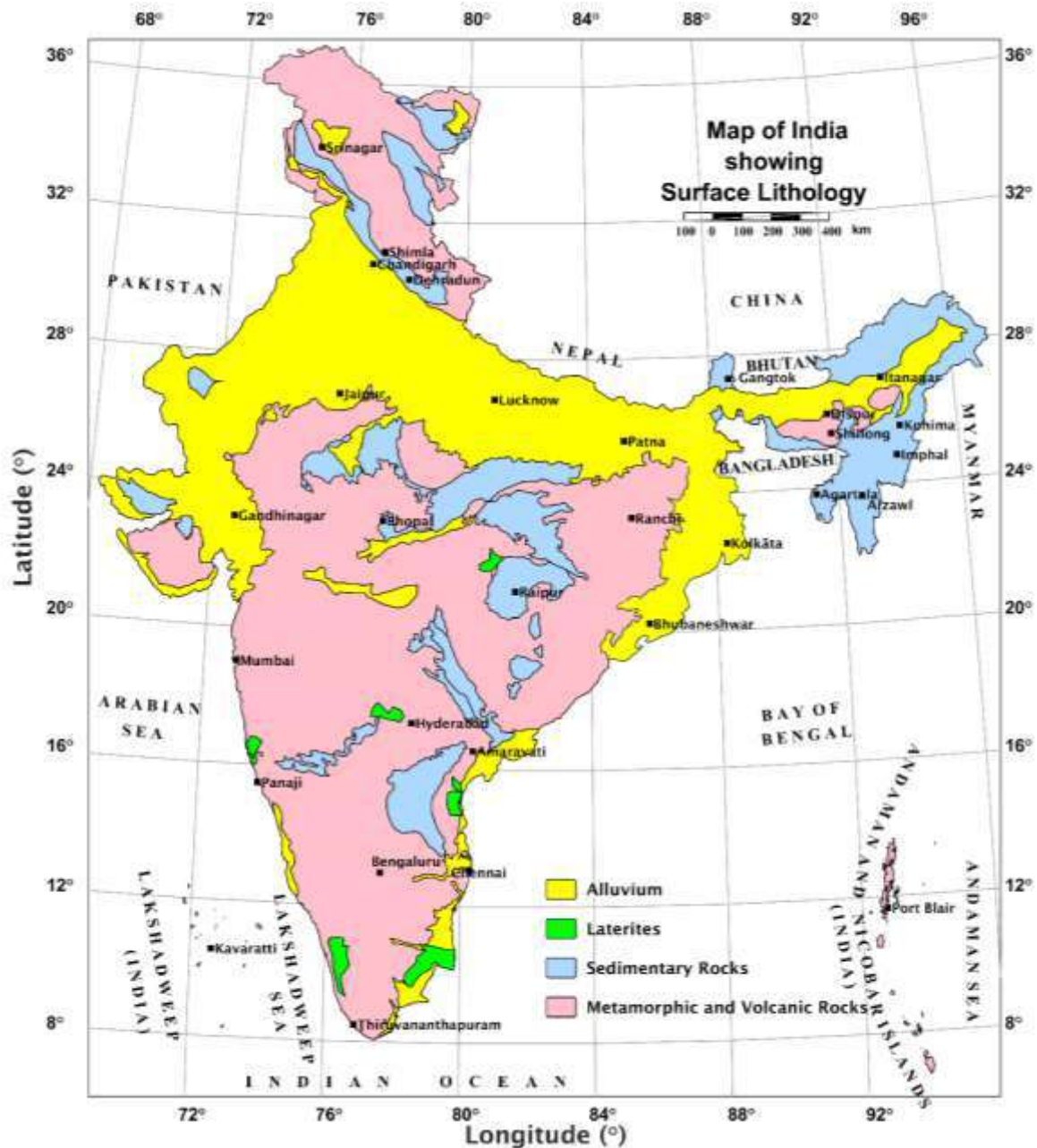

NOTES

- 1 This map is based upon Survey of India Political map printed in 2002.
- 2 The territorial waters of India extend into the sea to twelve nautical from the appropriate baseline.
- 3 The interstate boundaries between Arunachal Pradesh, Assam and Meghalaya shown on this map are as interpreted from the *North-Eastern Areas (Reorganization) Act, 1971*, but have yet to be verified.
- 4 The state boundaries between Uttarakhand and Uttar Pradesh, Bihar and Jharkhand, and Chhattisgarh and Madhya Pradesh have not been verified by the Governments concerned.
- 5 The administrative headquarters of Chandigarh, Haryana and Punjab are at Chandigarh.
- 6 The external boundaries and coastlines of India agree with the Record/Master Copy certified by Survey of India.
- 7 The responsibility for the correctness of internal rests with the publication.

FIG. 11 MAP OF INDIA SHOWING PRINCIPAL LITHOLOGICAL GROUPS CONSIDERED IN EARTHQUAKE HAZARD ASSESSMENT

ANNEX D

(Clause 6.2.1)

EARTHQUAKE ZONES OF SELECT TOWNS AND CITIES

D-1 EARTHQUAKE ZONE AND ZONE FACTOR OF SELECT TOWNS AND CITIES

The earthquake zone factors mentioned in Table 18 are those corresponding to the return period of 2 475 years.

Table 18 Earthquake Zone Factors of Select Towns and Cities of India

(Clause D-1)

SI No.	Town	Zone	Z
(1)	(2)	(3)	(4)
1	Agartala	VI	0.75
2	Agra	III	0.25
3	Ahilyanagar	II	0.15
4	Ahmedabad	IV	0.35
5	Aizawl	VI	0.75
6	Ajmer	III	0.25
7	Akola	II	0.15
8	Aligarh	IV	0.35
9	Almora	VI	0.75
10	Alwar	IV	0.35
11	Ambala	V	0.50
12	Ambassa	VI	0.75
13	Ambattur	III	0.25
14	Ambernath	III	0.25
15	Amravati	III	0.25
16	Amritsar	V	0.50
17	Anantapur	II	0.15
18	Anantnag	VI	0.75
19	Arrah	III	0.25
20	Asansol	IV	0.35
21	Avadi	III	0.25
22	Bahraich	V	0.50
23	Bally	IV	0.35
24	Bengaluru	II	0.15
25	Baranagar	IV	0.35
26	Barasat	IV	0.35
27	Barauni	IV	0.35
28	Barddhaman	IV	0.35
29	Bareilly	V	0.50
30	Begusarai	IV	0.35

SI No.	Town	Zone	Z
(1)	(2)	(3)	(4)
31	Belagavi	II	0.15
32	Ballari	II	0.15
33	Brahmapur	II	0.15
34	Bhagalpur	V	0.50
35	Bharatpur	III	0.25
36	Bhatinda	III	0.25
37	Bhatpara	IV	0.35
38	Bhavnagar	IV	0.35
39	Bhilai	II	0.15
40	Bhilwara	II	0.15
41	Bhiwadi	IV	0.35
42	Bhiwandi	III	0.25
43	Bhopal	II	0.15
44	Bhubaneshwar	III	0.25
45	Bhuj	VI	0.75
46	Bidar	II	0.15
47	Bidhan Nagar	IV	0.35
48	Biharsharif	III	0.25
49	Bikaner	II	0.15
50	Bilaspur	II	0.15
51	Bokaro	III	0.25
52	Bulandshahr	IV	0.35
53	Burdwan	IV	0.35
54	Burhanpur	III	0.25
55	Kozhikode	III	0.25
56	Champhai	VI	0.75
57	Chandigarh	VI	0.75
58	Chandrapur	II	0.15
59	Chhapra	IV	0.35
60	Chhatrapati Sambhajinagar	II	0.15
61	Chennai	III	0.25
62	Chitradurga	II	0.15
63	Coimbatore	III	0.25
64	Cuddalore	III	0.25
65	Cuttack	III	0.25
66	Daman	III	0.25

SI No.	Town	Zone	Z
(1)	(2)	(3)	(4)
67	Darbhanga	V	0.50
68	Darjeeling	VI	0.75
69	Davanagere	II	0.15
70	Dehradun	VI	0.75
71	Delhi	IV	0.35
72	Deoghar	III	0.25
73	Dewas	II	0.15
74	Dhanbad	III	0.25
75	Dharashiv	III	0.25
76	Dharwad	II	0.15
77	Dhule	II	0.15
78	Dibrugarh	VI	0.75
79	Dimapur	VI	0.75
80	Dindigul	III	0.25
81	Dispur	VI	0.75
82	Diu	III	0.25
83	Durg	II	0.15
84	Durgapur	IV	0.35
85	Eluru	III	0.25
86	English Bazar	V	0.50
87	Etawah	II	0.15
88	Faridabad	IV	0.35
89	Farrukhabad	III	0.25
90	Firozabad	III	0.25
91	Gandhidham	VI	0.75
92	Gandhinagar	IV	0.35
93	Ganganagar	II	0.15
94	Gangtok	VI	0.75
95	Gaya	III	0.25
96	Ghaziabad	IV	0.35
97	Gorakhpur	V	0.50
98	Guntur	III	0.25
99	Gurugram	IV	0.35
100	Guwahati	VI	0.75
101	Gwalior	II	0.15
102	Haldia	IV	0.35

Sl No.	Town	Zone	Z
(1)	(2)	(3)	(4)
103	Haldwani	VI	0.75
104	Howrah	IV	0.35
105	Hapur	IV	0.35
106	Haridwar	VI	0.75
107	Hisar	IV	0.35
108	Hosapete	II	0.15
109	Hubbali	II	0.15
110	Hyderabad	II	0.15
111	Ichalkaranji	III	0.25
112	Imphal	VI	0.75
113	Indore	III	0.25
114	Itanagar	VI	0.75
115	Jabalpur	III	0.25
116	Jaipur	IV	0.35
117	Jalandhar	V	0.50
118	Jalgaon	III	0.25
119	Jalna	II	0.15
120	Jammu	VI	0.75
121	Jamnagar	IV	0.35
122	Jamshedpur	III	0.25
123	Jhansi	II	0.15
124	Jodhpur	III	0.25
125	Jorhat	VI	0.75
126	Junagadh	III	0.25
127	Kadapa	II	0.15
128	Kakching	VI	0.75
129	Kakinada	III	0.25
130	Kakrapara	IV	0.35
131	Kalpakkam	III	0.25
132	Kalyan	III	0.25
133	Kamarhati	IV	0.35
134	Kanchipuram	III	0.25
135	Kanpur	III	0.25
136	Karawal	IV	0.35
137	Karimnagar	II	0.15
138	Karnal	V	0.50
139	Karwar	II	0.15

Sl No.	Town	Zone	Z
(1)	(2)	(3)	(4)
140	Katihar	V	0.50
141	Kavaratti	II	0.15
142	Khandwa	III	0.25
143	Kharagpur	IV	0.35
144	Kochi	III	0.25
145	Kohima	VI	0.75
146	Kolhapur	IV	0.35
147	Kolkata	IV	0.35
148	Kollam	II	0.15
149	Korba	II	0.15
150	Kota	II	0.15
151	Kulti	IV	0.35
152	Kurnool	II	0.15
153	Latur	III	0.25
154	Leh	VI	0.75
155	Loni	IV	0.35
156	Lucknow	III	0.25
157	Ludhiana	V	0.50
158	Madurai	III	0.25
159	Maheshtala	IV	0.35
160	Malegaon	II	0.15
161	Mandi	VI	0.75
162	Mangaluru	II	0.15
163	Mathura	III	0.25
164	Meerut	V	0.50
165	Mirzapur	III	0.25
166	Moradabad	V	0.50
167	Morena	II	0.15
168	Mumbai	III	0.25
169	Mungher	IV	0.35
170	Murwara	III	0.25
171	Muzaffarnagar	V	0.50
172	Muzaffarpur	V	0.50
173	Mysuru	II	0.15
174	Nadiad	IV	0.35
175	Nagarjuna Sagar	II	0.15
176	Nagercoil	II	0.15

SI No.	Town	Zone	Z
(1)	(2)	(3)	(4)
177	Nagpur	II	0.15
178	Naharlagun	VI	0.75
179	Naihati	IV	0.35
180	Nainital	VI	0.75
181	Namchi	VI	0.75
182	Nanded	II	0.15
183	Nandyal	II	0.15
184	Nangloi	IV	0.35
185	Nashik	III	0.25
186	Navi Mumbai	III	0.25
187	Nellore	III	0.25
188	Nizamabad	III	0.25
189	Noida	IV	0.35
190	Ongole	III	0.25
191	Kalaburagi	II	0.15
192	Ozhukarai	III	0.25
193	Pali	III	0.25
194	Pallavaram	III	0.25
195	Panaji	II	0.15
196	Panchkula	VI	0.75
197	Panihati	IV	0.35
198	Panipat	V	0.50
199	Parbhani	II	0.15
200	Patiala	V	0.50
210	Patna	IV	0.35
211	Pilibhit	V	0.50
212	Pimpri-Chinchwad	III	0.25
213	Puducherry	III	0.25
214	Port Blair	VI	0.75
215	Prayagraj	II	0.15
216	Pune	III	0.25
217	Puri Town	III	0.25
218	Purnia	V	0.50
219	Raichur	II	0.15
220	Raipur	II	0.15
221	Rajahmahendravaram	III	0.25
222	Rajarhat Gopalpur	IV	0.35

SI No.	Town	Zone	Z
(1)	(2)	(3)	(4)
223	Rajkot	IV	0.35
224	Rajpur Sonarpur	IV	0.35
225	Ramagundam	II	0.15
226	Rampur	V	0.50
227	Ranchi	III	0.25
228	Ratlam	II	0.15
229	Rourkela	III	0.25
230	Rewa	II	0.15
231	Rohtak	IV	0.35
232	Roorkee	VI	0.75
233	Sagar	II	0.15
234	Saharanpur	V	0.50
235	Salem	III	0.25
236	Sambhal	IV	0.35
237	Sangli Miraj	III	0.25
238	Satna	II	0.15
239	Secunderabad	II	0.15
240	Shahjahanpur	IV	0.35
241	Shillong	VI	0.75
242	Shimla	VI	0.75
243	Shivamogga	II	0.15
244	Sikar	III	0.25
245	Siliguri	VI	0.75
246	Singrauli	IV	0.35
247	Sironj	II	0.15
248	Solapur	III	0.25
249	Sonipat	IV	0.35
250	Srinagar	VI	0.75
251	Surat	IV	0.35
252	Tarapur	III	0.25
253	Tezpur	VI	0.75
254	Thane	III	0.25
255	Thanjavur	III	0.25
256	Thiruvananthapuram	II	0.15
257	Thiruvannamalai	III	0.25
258	Thoothukkudi	II	0.15

Sl No.	Town	Zone	Z
(1)	(2)	(3)	(4)
259	Thrissur	III	0.25
260	Tiruchirappalli	III	0.25
261	Tirunelveli	II	0.15
262	Tirupati	III	0.25
263	Tiruppur	III	0.25
264	Tiruvottiyur	III	0.25
265	Tumakuru	II	0.15
266	Udaipur	III	0.25
267	Ujjain	II	0.15
268	Ulhasnagar	III	0.25
269	Uluberia	IV	0.35
270	Vadodara	IV	0.35
271	Varanasi	III	0.25
272	Vasai-Virar	III	0.25
273	Vellore	III	0.25
274	Vijayapura	II	0.15
275	Vijayawada	III	0.25
276	Vishakhapatnam	II	0.15
277	Vizianagaram	II	0.15
278	Warangal	II	0.15
279	Yamunanagar	V	0.50

ANNEX E

(Clauses 8.3.3.3(d)(1)(i) and C-5.1)

GROUND MOTIONS FOR LINEAR AND NONLINEAR DYNAMIC ANALYSES OF STRUCTURES

E-1 INTRODUCTION

The linear and nonlinear response history methods of earthquake analysis of structures shall consider realistic and strong earthquake ground motions to obtain the responses of structure (both stress resultants in structural elements and deformations in members and at nodes of the structure) at each time instance. The strong ground motions appropriate for use in response history method shall be:

- a) consistent with the tectonic and geotechnical conditions of the project site, to the extent possible;
- b) compatible with the design acceleration spectrum in the range of natural periods of the natural modes that contribute most to the response of the structure. Strong ground motions may not be available, which are compatible over the entire applicable range of natural periods of the design response spectrum. In such cases, suites of ground motions compatible over small windows of natural periods as mentioned in **E-2.3(a)** shall be used; and
- c) while examining the responses of the structure, it is necessary to consider the envelope response of the structure to these ground motions.

E-2 SELECTION OF EARTHQUAKE GROUND MOTIONS

The ground motions are provided in the form of acceleration histories recorded during earthquakes worldwide scaled to match the design uniform hazard spectrum. Each ground motion consists of three components of acceleration along three cartesian directions – two along horizontal directions and one along the vertical direction. These shall be used in response history analysis of structures for:

- a) earthquake-resistant design of structures; and
- b) earthquake performance assessment of structures.

E-2.1 Database

The ground motion database considered includes those collected from open-source databases, like

NGA West2, NGA East, NGA Subduction, Japan, India, Turkey, ESM (Engineering Strong Motion), and New Zealand datasets. The compiled database consists of about 15 lakh ground acceleration histories, each comprising three components (two horizontal and one vertical), hereinafter referred to as the ground motion library. Each record has key metadata, like moment magnitude M_w , time-averaged shear-wave velocity $V_{s,30}$ of the top 30 m of geotechnical strata, and epicentral distance R_{epi} . The distribution of M_w and R_{epi} of the said ground motions is illustrated in Fig. 12.

E-2.2 Target Spectrum

According to this standard, the Indian landmass is placed in five earthquake zones, namely earthquake Zones II, III, IV, V and VI, based on the earthquake hazard corresponding to the 2 475 years return period. An idealized normalized PSA spectrum is provided, which is stated to be the same across all five earthquake zones but with different corner periods for the different soil site classes, namely Site Classes A and B, Site Class C and Site Class D. This spectrum has sharp corners especially at the junction of the acceleration-sensitive and velocity-sensitive regions of the normalized PSA spectrum, and when estimating the design acceleration, this normalized acceleration is scaled by the respective earthquake zone factor Z .

In contrast, when selecting and scaling ground motions, a smooth $(\mu + 1.65\sigma)$ uniform hazard response spectrum (UHRS) is taken as target response spectrum defined separately for each earthquake zone. This target UHRS is derived from site-specific probabilistic earthquake hazard analyses (PEHA) performed at grid points spaced at $0.1^\circ \times 0.1^\circ$ intervals. The procedure is the same as that adopted in arriving at the macro-hazard (namely the earthquake zone factor Z) adopted by this standard. All individual UHRS at these grid points are normalized to unit peak ground acceleration (PGA) before computing the fractile spectrum, ensuring consistency across the zone. An example of the UHRS derived for earthquake Zone VI is shown in Fig. 13. For brevity, this fractile UHRS will be referred to simply as the UHRS.

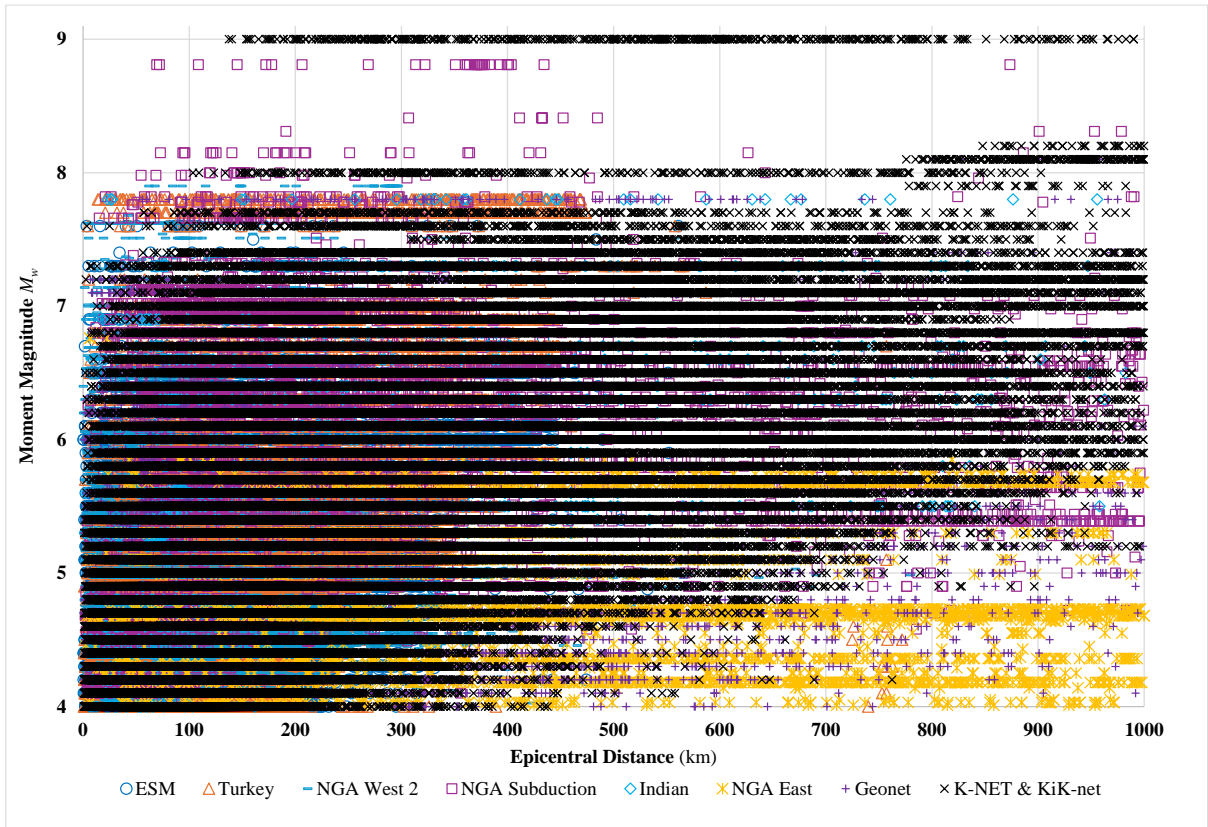

FIG. 12 DISTRIBUTION OF M_w AND R_{epi} OF THE GROUND MOTIONS CONSIDERED IN THE GROUND MOTION LIBRARY

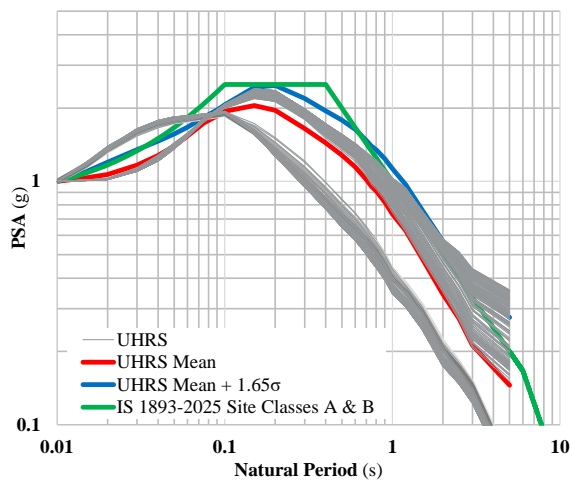

FIG. 13 (A)

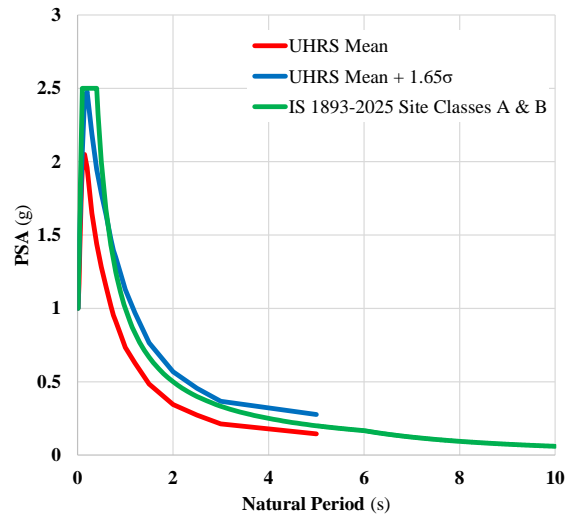

FIG. 13 (B)

FIG.13 FRACTILE UNIFORM HAZARD RESPONSE SPECTRUM OBTAINED FOR EARTHQUAKE ZONE VI

E-2.3 Screening

The ground motion library with about 15 lakh ground motions is screened initially based on the following considerations:

- a) *Sub-Intervals of Natural Period* — The total natural period range of 0 – 5 s is divided into ten intervals, namely 0 s to 0.1 s, 0.1 s to 0.2 s, 0.2 s to 0.3 s, 0.3 s to 0.4 s, 0.4 s to 0.5 s, 0.5 s to 1.0 s, 1.0 s to 2.0 s, 2.0 s to 3.0 s, 3.0 s to 4.0 s and 4.0 s to 5.0 s. The maximum-direction spectrum (RotD100, implying rotation dependent ground motion) computed from the two horizontal components is used to match with the target spectrum. The ground motions provided are along the direction that provides the highest spectral ordinate; this ground motion is denoted as RotI100, implying rotation independent ground motion;
- b) *Mean Spectrum* — The PSA spectrum of individual ground motions is scaled to

match only in one of the time windows mentioned in **E-2.3(a)**.

- 1) *Within natural period range* — Maximum error is ± 10 percent between the individual spectrum of selected ground motions and the target $(\mu + 1.65\sigma)$ UHRS; and
- 2) *Outside the natural period range* — Maximum error is + 10 percent between the individual spectrum of selected ground motions and the target $(\mu + 1.65\sigma)$ UHRS, but it can undershoot by any amount,
- c) *Scaling factors* — The recorded ground motions can be scaled by a scaling factor in the range 0.2 to 5.0.

A representative scaling of the selected ground motions in the period range 0.5 s to 1.0 s is illustrated in Fig.14.

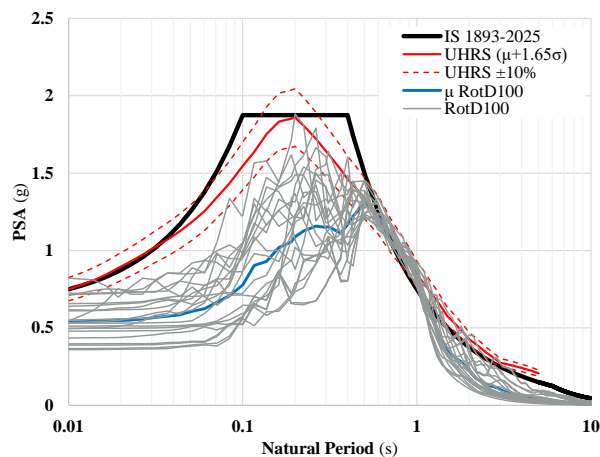

FIG. 14 (A)

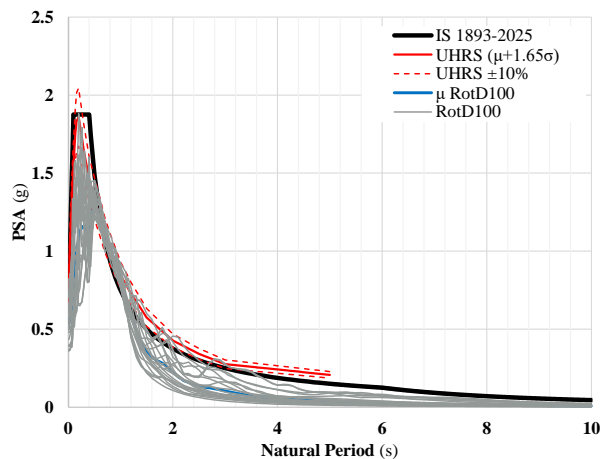

FIG. 14 (B)

FIG. 14 SCREENED GROUND MOTIONS WITHIN THE PERIOD RANGE 0.5 s TO 1.0 s FOR EARTHQUAKE ZONE VI

E-2.4 Selection

The screening of ground motions as per E-2.3 yields a large pool of potential ground motions for each of the ten natural period windows mentioned therein. The screened ground motions are shortlisted further to a total of 30 ground motions based on the following considerations:

- Maximum error is ± 10 percent between the envelope spectrum of the final selected ground motions and the target ($\mu + 1.65\sigma$) UHRS;
- The ground motions with excessively long durations (that is, 2 min) are excluded; and
- Three ground motions in each of the ten natural period windows mentioned in E-2.3 are selected, which have the lowest mean squared error between their individual spectra and the target UHRS.

The final selected 30 ground motions are shown in Fig. 15 for earthquake Zone VI for use at site Classes A and B.

The target UHRS is limited to natural period up to 5 s, because the GMPEs are limited to this value of natural period, but the design spectrum specified in this standard is up to 10 s. On the other hand, the PSA spectra of the final 30 ground motions selected reasonably reflect the design PSA spectrum in the range 5 s to 10 s also. Hence, no need is felt to

identify separate ground motions to represent the target spectrum in that range.

E-2.5 Duration

When peak response alone is of primary interest, structures need not be analysed for the full duration of the ground motion. Instead, they can be analysed for a duration that captures about 95 percent of the cumulative energy input by the ground motion. This duration can be determined using the normalized cumulative energy e given by:

$$e = \frac{\int_0^t |a_g v_g| dt}{\int_0^{T_d} |a_g v_g| dt}$$

where a_g and v_g are the acceleration and velocity of the ground motion, respectively, and T_d the total duration of the ground motion. This duration at which the 95 percent of the input energy is provided at the base of the structure may differ for each of the three components of the ground motion (Fig. 16). Hence, the largest of these durations of the three components of a ground motion at which the 95 percent of the energy is input to the structure shall be used as the truncated duration of ground motion T_{dt} . For convenience of use, this maximum duration is rounded upwards to the nearest multiple of 10 s.

In this Annex, both the full ground motion data, and the truncated ground motions with 95 percent input energy are provided.

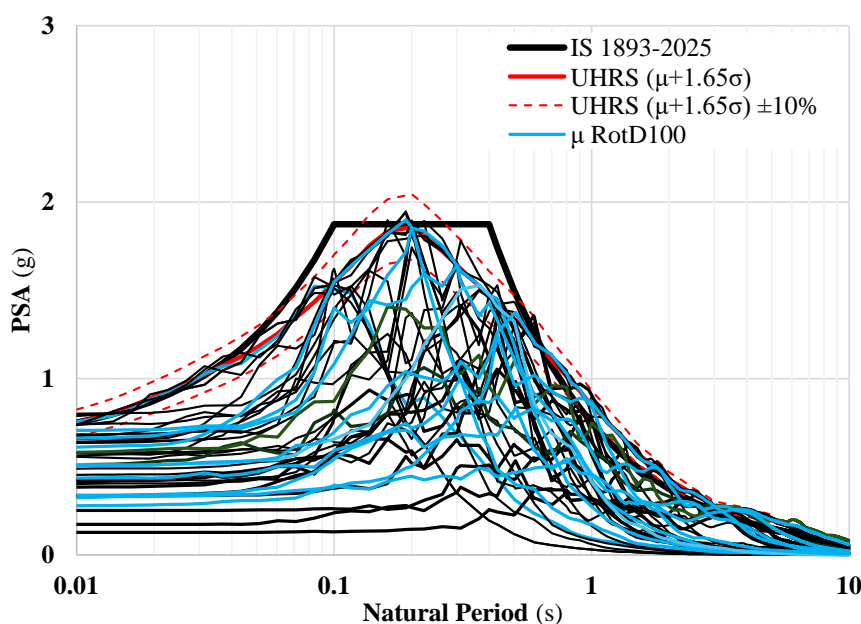

FIG. 15 30 SELECTED GROUND MOTIONS AT SITE CLASSES A AND B FOR EARTHQUAKE ZONE VI

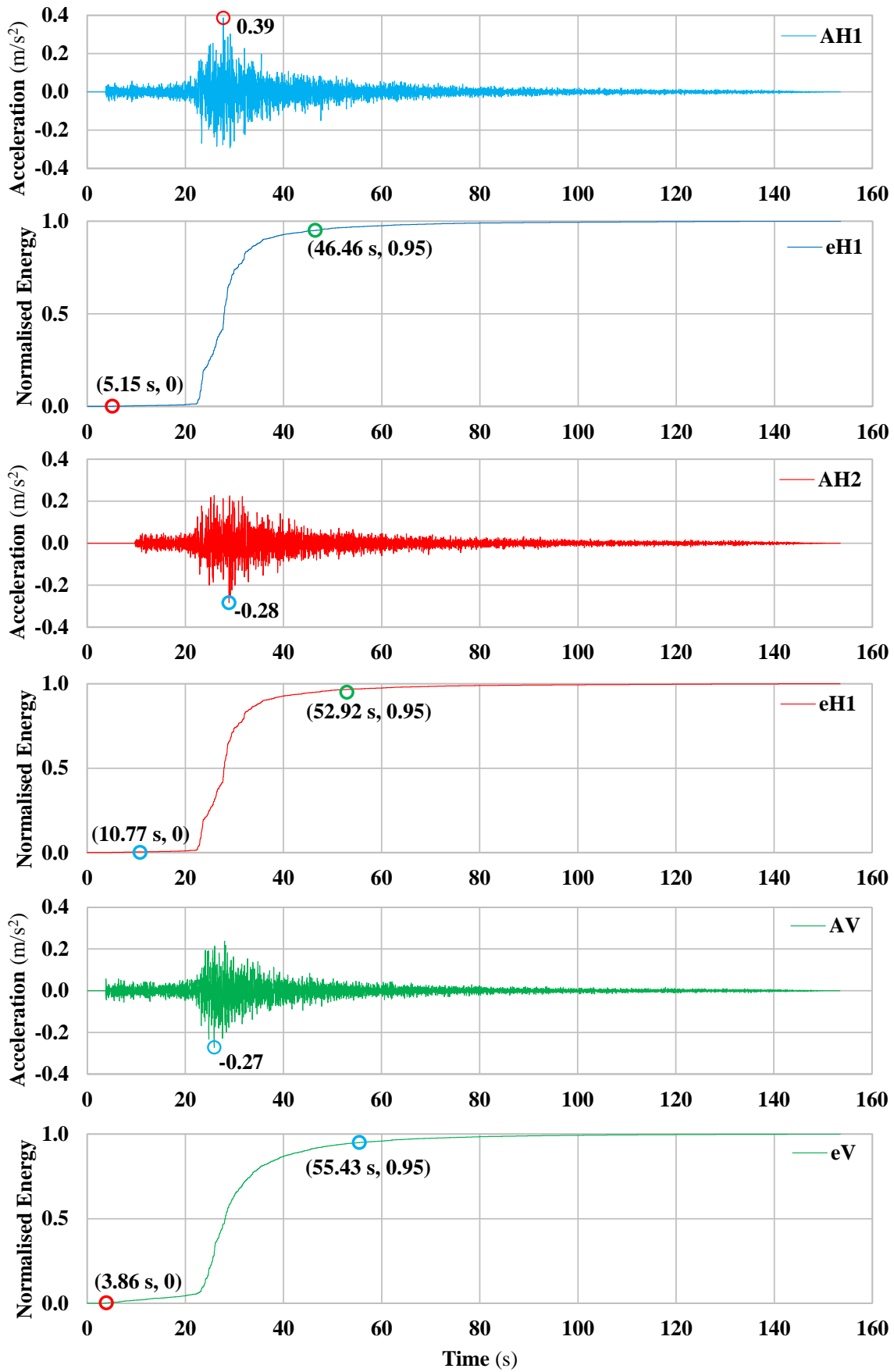

FIG. 16 GROUND MOTIONS HISTORIES SHOWING DURATION AT WHICH TO 95 PERCENT OF THE CUMULATIVE ENERGY IS INPUT TO THE STRUCTURE

E-3 USE OF GROUND MOTIONS

E-3.1 The ground motions compatible with the Design PSA Spectrum for different earthquake zones and in soil strata of different site classes are given in Table 19. Each ground motion is given a name in the form ZZZ-SC-100-LF# and ZZ-SC-95-LF##, as explained in Table 20; this nomenclature is used in Table 21 to Table 27.

E-3.2 The unit of acceleration in these ground motion histories is m/s^2 . The time increment of the subsequent acceleration values varies (0.02 s, 0.01 s or 0.005 s) and is provided in the individual text files describing the ground motion.

E-3.3 When earthquake analysis requires the use of velocity or displacement ground motion histories, the full ground motions mentioned in E-2.5 alone shall be used, and not the truncated ground motions.

E-3.4 The two horizontal components of a ground motion shall be oriented along principal plan directions of the structure.

E-3.5 The sampling rates are different of the ground motions provided in this standard, because they are from different instruments used over the last 8 decades of recording of the earthquake ground motions. The three components of a ground motion

shall be used with the sampling of the values as provided. Resampling (up or down) shall not be permitted.

E-3.6 The aforesaid ground motions can be downloaded from the BIS website.

E-4 NEAR-FAULT GROUND MOTIONS

In general, the above description of ground motion selection and use mentioned in E-2 and E-3 is valid for both near-fault and far-fault motions. But, while selecting the near-fault motions, the following additional care is taken:

- a) Only one database of recorded ground motions is used for near-fault motions, namely the NESS (Near-Source Strong-motion) database;
- b) The permissible error between the individual ground motion spectrum and the target spectrum is increased to ± 15 percent; and
- c) In earthquake Zones V and VI, both far-fault and near-fault ground motions shall be used and the envelope response shall be considered.

Table 19 Earthquake Ground Motions to be used in Response Spectrum Method of Earthquake Analysis of Structures

(Clause E-3.1)

SI No.	Earthquake Zone	Table Number for the Ground Motions to be Used	
		Far-Fault Ground Motions	Near-Fault Ground Motions
(1)	(2)	(3)	(4)
i)	VI	Table 21	Table 26
ii)	V	Table 22	Table 27
iii)	IV	Table 23	Not provided
iv)	III	Table 24	
v)	II	Table 25	

Table 20 Description of the Nomenclature of Each Ground Motion

(Clause E-3.1)

Sl No.	Part of the Nomenclature	Description of the Part of the Nomenclature
(1)	(2)	(3)
i)	ZZZ	Earthquake zone, namely earthquake Zone as II, III, IV, V or VI
ii)	SC	Site class, namely site Class A, B, C or D
iii)	100	Acceleration history of truncated duration that accounts for 100 percent of the specific energy when full ground motion is considered
	95	Acceleration history of truncated duration that accounts for 95 percent of the specific energy when full ground motion is considered
iv)	LF##	Location of fault, namely near fault (as NF) and far fault (FF), and two numerals indicating the serial number of the ground motion in the specified set

Table 21 Details of 30 Far-Fault Ground Motions Compatible with Design PSA Spectrum in Earthquake Zone VI

[Table 19, Sl No. (i)]

SI No.	Full Ground Motion with 100 percent Energy			Truncated Ground Motion with 95 percent Energy		
	Site Classes A and B	Site Class C	Site Class D	Site Classes A and B	Site Class C	Site Class D
(1)	(2)	(3)	(4)	(5)	(6)	(7)
i)	VI-AB-100-FF1	VI-C-100-FF1	VI-D-100-FF1	VI-AB-95-FF1	VI-C-95-FF1	VI-D-95-FF1
ii)	VI-AB-100-FF2	VI-C-100-FF2	VI-D-100-FF2	VI-AB-95-FF2	VI-C-95-FF2	VI-D-95-FF2
iii)	VI-AB-100-FF3	VI-C-100-FF3	VI-D-100-FF3	VI-AB-95-FF3	VI-C-95-FF3	VI-D-95-FF3
iv)	VI-AB-100-FF4	VI-C-100-FF4	VI-D-100-FF4	VI-AB-95-FF4	VI-C-95-FF4	VI-D-95-FF4
v)	VI-AB-100-FF5	VI-C-100-FF5	VI-D-100-FF5	VI-AB-95-FF5	VI-C-95-FF5	VI-D-95-FF5
vi)	VI-AB-100-FF6	VI-C-100-FF6	VI-D-100-FF6	VI-AB-95-FF6	VI-C-95-FF6	VI-D-95-FF6
vii)	VI-AB-100-FF7	VI-C-100-FF7	VI-D-100-FF7	VI-AB-95-FF7	VI-C-95-FF7	VI-D-95-FF7
viii)	VI-AB-100-FF8	VI-C-100-FF8	VI-D-100-FF8	VI-AB-95-FF8	VI-C-95-FF8	VI-D-95-FF8
ix)	VI-AB-100-FF9	VI-C-100-FF9	VI-D-100-FF9	VI-AB-95-FF9	VI-C-95-FF9	VI-D-95-FF9
x)	VI-AB-100-FF10	VI-C-100-FF10	VI-D-100-FF10	VI-AB-95-FF10	VI-C-95-FF10	VI-D-95-FF10
xi)	VI-AB-100-FF11	VI-C-100-FF11	VI-D-100-FF11	VI-AB-95-FF11	VI-C-95-FF11	VI-D-95-FF11
xii)	VI-AB-100-FF12	VI-C-100-FF12	VI-D-100-FF12	VI-AB-95-FF12	VI-C-95-FF12	VI-D-95-FF12
xiii)	VI-AB-100-FF13	VI-C-100-FF13	VI-D-100-FF13	VI-AB-95-FF13	VI-C-95-FF13	VI-D-95-FF13
xiv)	VI-AB-100-FF14	VI-C-100-FF14	VI-D-100-FF14	VI-AB-95-FF14	VI-C-95-FF14	VI-D-95-FF14
xv)	VI-AB-100-FF15	VI-C-100-FF15	VI-D-100-FF15	VI-AB-95-FF15	VI-C-95-FF15	VI-D-95-FF15

SI No.	Full Ground Motion with 100 percent Energy			Truncated Ground Motion with 95 percent Energy		
	Site Classes A and B	Site Class C	Site Class D	Site Classes A and B	Site Class C	Site Class D
(1)	(2)	(3)	(4)	(5)	(6)	(7)
xvi)	VI-AB-100-FF16	VI-C-100-FF16	VI-D-100-FF16	VI-AB-95-FF16	VI-C-95-FF16	VI-D-95-FF16
xvii)	VI-AB-100-FF17	VI-C-100-FF17	VI-D-100-FF17	VI-AB-95-FF17	VI-C-95-FF17	VI-D-95-FF17
xviii)	VI-AB-100-FF18	VI-C-100-FF18	VI-D-100-FF18	VI-AB-95-FF18	VI-C-95-FF18	VI-D-95-FF18
xix)	VI-AB-100-FF19	VI-C-100-FF19	VI-D-100-FF19	VI-AB-95-FF19	VI-C-95-FF19	VI-D-95-FF19
xx)	VI-AB-100-FF20	VI-C-100-FF20	VI-D-100-FF20	VI-AB-95-FF20	VI-C-95-FF20	VI-D-95-FF20
xxi)	VI-AB-100-FF21	VI-C-100-FF21	VI-D-100-FF21	VI-AB-95-FF21	VI-C-95-FF21	VI-D-95-FF21
xxii)	VI-AB-100-FF22	VI-C-100-FF22	VI-D-100-FF22	VI-AB-95-FF22	VI-C-95-FF22	VI-D-95-FF22
xxiii)	VI-AB-100-FF23	VI-C-100-FF23	VI-D-100-FF23	VI-AB-95-FF23	VI-C-95-FF23	VI-D-95-FF23
xxiv)	VI-AB-100-FF24	VI-C-100-FF24	VI-D-100-FF24	VI-AB-95-FF24	VI-C-95-FF24	VI-D-95-FF24
xxv)	VI-AB-100-FF25	VI-C-100-FF25	VI-D-100-FF25	VI-AB-95-FF25	VI-C-95-FF25	VI-D-95-FF25
xxvi)	VI-AB-100-FF26	VI-C-100-FF26	VI-D-100-FF26	VI-AB-95-FF26	VI-C-95-FF26	VI-D-95-FF26
xxvii)	VI-AB-100-FF27	VI-C-100-FF27	VI-D-100-FF27	VI-AB-95-FF27	VI-C-95-FF27	VI-D-95-FF27
xxviii)	VI-AB-100-FF28	VI-C-100-FF28	VI-D-100-FF28	VI-AB-95-FF28	VI-C-95-FF28	VI-D-95-FF28
xxix)	VI-AB-100-FF29	VI-C-100-FF29	VI-D-100-FF29	VI-AB-95-FF29	VI-C-95-FF29	VI-D-95-FF29
xxx)	VI-AB-100-FF30	VI-C-100-FF30	VI-D-100-FF30	VI-AB-95-FF30	VI-C-95-FF30	VI-D-95-FF30

Table 22 Details of 30 Far-Fault Ground Motions Compatible with Design PSA Spectrum in Earthquake Zone V

[Table 19, Sl No. (ii)]

SI No.	Full Ground Motion with 100 percent Energy			Truncated Ground Motion with 95 percent Energy		
	Site Classes A and B	Site Class C	Site Class D	Site Classes A and B	Site Class C	Site Class D
(1)	(2)	(3)	(4)	(5)	(6)	(7)
i)	V-AB-100-FF1	V-C-100-FF1	V-D-100-FF1	V-AB-95-FF1	V-C-95-FF1	V-D-95-FF1
ii)	V-AB-100-FF2	V-C-100-FF2	V-D-100-FF2	V-AB-95-FF2	V-C-95-FF2	V-D-95-FF2
iii)	V-AB-100-FF3	V-C-100-FF3	V-D-100-FF3	V-AB-95-FF3	V-C-95-FF3	V-D-95-FF3
iv)	V-AB-100-FF4	V-C-100-FF4	V-D-100-FF4	V-AB-95-FF4	V-C-95-FF4	V-D-95-FF4
v)	V-AB-100-FF5	V-C-100-FF5	V-D-100-FF5	V-AB-95-FF5	V-C-95-FF5	V-D-95-FF5
vi)	V-AB-100-FF6	V-C-100-FF6	V-D-100-FF6	V-AB-95-FF6	V-C-95-FF6	V-D-95-FF6
vii)	V-AB-100-FF7	V-C-100-FF7	V-D-100-FF7	V-AB-95-FF7	V-C-95-FF7	V-D-95-FF7
viii)	V-AB-100-FF8	V-C-100-FF8	V-D-100-FF8	V-AB-95-FF8	V-C-95-FF8	V-D-95-FF8
ix)	V-AB-100-FF9	V-C-100-FF9	V-D-100-FF9	V-AB-95-FF9	V-C-95-FF9	V-D-95-FF9
x)	V-AB-100-FF10	V-C-100-FF10	V-D-100-FF10	V-AB-95-FF10	V-C-95-FF10	V-D-95-FF10
xi)	V-AB-100-FF11	V-C-100-FF11	V-D-100-FF11	V-AB-95-FF11	V-C-95-FF11	V-D-95-FF11
xii)	V-AB-100-FF12	V-C-100-FF12	V-D-100-FF12	V-AB-95-FF12	V-C-95-FF12	V-D-95-FF12
xiii)	V-AB-100-FF13	V-C-100-FF13	V-D-100-FF13	V-AB-95-FF13	V-C-95-FF13	V-D-95-FF13
xiv)	V-AB-100-FF14	V-C-100-FF14	V-D-100-FF14	V-AB-95-FF14	V-C-95-FF14	V-D-95-FF14
xv)	V-AB-100-FF15	V-C-100-FF15	V-D-100-FF15	V-AB-95-FF15	V-C-95-FF15	V-D-95-FF15
xvi)	V-AB-100-FF16	V-C-100-FF16	V-D-100-FF16	V-AB-95-FF16	V-C-95-FF16	V-D-95-FF16
xvii)	V-AB-100-FF17	V-C-100-FF17	V-D-100-FF17	V-AB-95-FF17	V-C-95-FF17	V-D-95-FF17
xviii)	V-AB-100-FF18	V-C-100-FF18	V-D-100-FF18	V-AB-95-FF18	V-C-95-FF18	V-D-95-FF18

SI No.	Full Ground Motion with 100 percent Energy			Truncated Ground Motion with 95 percent Energy		
	Site Classes A and B	Site Class C	Site Class D	Site Classes A and B	Site Class C	Site Class D
(1)	(2)	(3)	(4)	(5)	(6)	(7)
xix)	V-AB-100-FF19	V-C-100-FF19	V-D-100-FF19	V-AB-95-FF19	V-C-95-FF19	V-D-95-FF19
xx)	V-AB-100-FF20	V-C-100-FF20	V-D-100-FF20	V-AB-95-FF20	V-C-95-FF20	V-D-95-FF20
xxi)	V-AB-100-FF21	V-C-100-FF21	V-D-100-FF21	V-AB-95-FF21	V-C-95-FF21	V-D-95-FF21
xxii)	V-AB-100-FF22	V-C-100-FF22	V-D-100-FF22	V-AB-95-FF22	V-C-95-FF22	V-D-95-FF22
xxiii)	V-AB-100-FF23	V-C-100-FF23	V-D-100-FF23	V-AB-95-FF23	V-C-95-FF23	V-D-95-FF23
xxiv)	V-AB-100-FF24	V-C-100-FF24	V-D-100-FF24	V-AB-95-FF24	V-C-95-FF24	V-D-95-FF24
xxv)	V-AB-100-FF25	V-C-100-FF25	V-D-100-FF25	V-AB-95-FF25	V-C-95-FF25	V-D-95-FF25
xxvi)	V-AB-100-FF26	V-C-100-FF26	V-D-100-FF26	V-AB-95-FF26	V-C-95-FF26	V-D-95-FF26
xxvii)	V-AB-100-FF27	V-C-100-FF27	V-D-100-FF27	V-AB-95-FF27	V-C-95-FF27	V-D-95-FF27
xxviii)	V-AB-100-FF28	V-C-100-FF28	V-D-100-FF28	V-AB-95-FF28	V-C-95-FF28	V-D-95-FF28
xxix)	V-AB-100-FF29	V-C-100-FF29	V-D-100-FF29	V-AB-95-FF29	V-C-95-FF29	V-D-95-FF29
xxx)	V-AB-100-FF30	V-C-100-FF30	V-D-100-FF30	V-AB-95-FF30	V-C-95-FF30	V-D-95-FF30

Table 23 Details of 30 Far-Fault Ground Motions Compatible with Design PSA Spectrum in Earthquake Zone IV

[Table 19, SI No. (iii)]

SI No.	Full Ground Motion with 100 percent Energy			Truncated Ground Motion with 95 percent Energy		
	Site Classes A and B	Site Class C	Site Class D	Site Classes A and B	Site Class C	Site Class D
(1)	(2)	(3)	(4)	(5)	(6)	(7)
i)	IV-AB-100-FF1	IV-C-100-FF1	IV-D-100-FF1	IV-AB-95-FF1	IV-C-95-FF1	IV-D-95-FF1
ii)	IV-AB-100-FF2	IV-C-100-FF2	IV-D-100-FF2	IV-AB-95-FF2	IV-C-95-FF2	IV-D-95-FF2
iii)	IV-AB-100-FF3	IV-C-100-FF3	IV-D-100-FF3	IV-AB-95-FF3	IV-C-95-FF3	IV-D-95-FF3
iv)	IV-AB-100-FF4	IV-C-100-FF4	IV-D-100-FF4	IV-AB-95-FF4	IV-C-95-FF4	IV-D-95-FF4
v)	IV-AB-100-FF5	IV-C-100-FF5	IV-D-100-FF5	IV-AB-95-FF5	IV-C-95-FF5	IV-D-95-FF5
vi)	IV-AB-100-FF6	IV-C-100-FF6	IV-D-100-FF6	IV-AB-95-FF6	IV-C-95-FF6	IV-D-95-FF6
vii)	IV-AB-100-FF7	IV-C-100-FF7	IV-D-100-FF7	IV-AB-95-FF7	IV-C-95-FF7	IV-D-95-FF7
viii)	IV-AB-100-FF8	IV-C-100-FF8	IV-D-100-FF8	IV-AB-95-FF8	IV-C-95-FF8	IV-D-95-FF8
ix)	IV-AB-100-FF9	IV-C-100-FF9	IV-D-100-FF9	IV-AB-95-FF9	IV-C-95-FF9	IV-D-95-FF9
x)	IV-AB-100-FF10	IV-C-100-FF10	IV-D-100-FF10	IV-AB-95-FF10	IV-C-95-FF10	IV-D-95-FF10
xi)	IV-AB-100-FF11	IV-C-100-FF11	IV-D-100-FF11	IV-AB-95-FF11	IV-C-95-FF11	IV-D-95-FF11
xii)	IV-AB-100-FF12	IV-C-100-FF12	IV-D-100-FF12	IV-AB-95-FF12	IV-C-95-FF12	IV-D-95-FF12
xiii)	IV-AB-100-FF13	IV-C-100-FF13	IV-D-100-FF13	IV-AB-95-FF13	IV-C-95-FF13	IV-D-95-FF13
xiv)	IV-AB-100-FF14	IV-C-100-FF14	IV-D-100-FF14	IV-AB-95-FF14	IV-C-95-FF14	IV-D-95-FF14
xv)	IV-AB-100-FF15	IV-C-100-FF15	IV-D-100-FF15	IV-AB-95-FF15	IV-C-95-FF15	IV-D-95-FF15
xvi)	IV-AB-100-FF16	IV-C-100-FF16	IV-D-100-FF16	IV-AB-95-FF16	IV-C-95-FF16	IV-D-95-FF16

SI No.	Full Ground Motion with 100 percent Energy			Truncated Ground Motion with 95 percent Energy		
	Site Classes A and B	Site Class C	Site Class D	Site Classes A and B	Site Class C	Site Class D
(1)	(2)	(3)	(4)	(5)	(6)	(7)
xvii)	IV-AB-100-FF17	IV-C-100-FF17	IV-D-100-FF17	IV-AB-95-FF17	IV-C-95-FF17	IV-D-95-FF17
xviii)	IV-AB-100-FF18	IV-C-100-FF18	IV-D-100-FF18	IV-AB-95-FF18	IV-C-95-FF18	IV-D-95-FF18
xix)	IV-AB-100-FF19	IV-C-100-FF19	IV-D-100-FF19	IV-AB-95-FF19	IV-C-95-FF19	IV-D-95-FF19
xx)	IV-AB-100-FF20	IV-C-100-FF20	IV-D-100-FF20	IV-AB-95-FF20	IV-C-95-FF20	IV-D-95-FF20
xxi)	IV-AB-100-FF21	IV-C-100-FF21	IV-D-100-FF21	IV-AB-95-FF21	IV-C-95-FF21	IV-D-95-FF21
xxii)	IV-AB-100-FF22	IV-C-100-FF22	IV-D-100-FF22	IV-AB-95-FF22	IV-C-95-FF22	IV-D-95-FF22
xxiii)	IV-AB-100-FF23	IV-C-100-FF23	IV-D-100-FF23	IV-AB-95-FF23	IV-C-95-FF23	IV-D-95-FF23
xxiv)	IV-AB-100-FF24	IV-C-100-FF24	IV-D-100-FF24	IV-AB-95-FF24	IV-C-95-FF24	IV-D-95-FF24
xxv)	IV-AB-100-FF25	IV-C-100-FF25	IV-D-100-FF25	IV-AB-95-FF25	IV-C-95-FF25	IV-D-95-FF25
xxvi)	IV-AB-100-FF26	IV-C-100-FF26	IV-D-100-FF26	IV-AB-95-FF26	IV-C-95-FF26	IV-D-95-FF26
xxvii)	IV-AB-100-FF27	IV-C-100-FF27	IV-D-100-FF27	IV-AB-95-FF27	IV-C-95-FF27	IV-D-95-FF27
xxviii)	IV-AB-100-FF28	IV-C-100-FF28	IV-D-100-FF28	IV-AB-95-FF28	IV-C-95-FF28	IV-D-95-FF28
xxix)	IV-AB-100-FF29	IV-C-100-FF29	IV-D-100-FF29	IV-AB-95-FF29	IV-C-95-FF29	IV-D-95-FF29
xxx)	IV-AB-100-FF30	IV-C-100-FF30	IV-D-100-FF30	IV-AB-95-FF30	IV-C-95-FF30	IV-D-95-FF30

Table 24 Details of 30 far-fault ground motions compatible with Design PSA Spectrum in Earthquake Zone III

[Table 19, SI No. (iv)]

SI No.	Full Ground Motion with 100 percent Energy			Truncated Ground Motion with 95 percent Energy		
	Site Classes A and B	Site Class C	Site Class D	Site Classes A and B	Site Class C	Site Class D
(1)	(2)	(3)	(4)	(5)	(6)	(7)
i)	III-AB-100-FF1	III-C-100-FF1	III-D-100-FF1	III-AB-95-FF1	III-C-95-FF1	III-D-95-FF1
ii)	III-AB-100-FF2	III-C-100-FF2	III-D-100-FF2	III-AB-95-FF2	III-C-95-FF2	III-D-95-FF2
iii)	III-AB-100-FF3	III-C-100-FF3	III-D-100-FF3	III-AB-95-FF3	III-C-95-FF3	III-D-95-FF3
iv)	III-AB-100-FF4	III-C-100-FF4	III-D-100-FF4	III-AB-95-FF4	III-C-95-FF4	III-D-95-FF4
v)	III-AB-100-FF5	III-C-100-FF5	III-D-100-FF5	III-AB-95-FF5	III-C-95-FF5	III-D-95-FF5
vi)	III-AB-100-FF6	III-C-100-FF6	III-D-100-FF6	III-AB-95-FF6	III-C-95-FF6	III-D-95-FF6
vii)	III-AB-100-FF7	III-C-100-FF7	III-D-100-FF7	III-AB-95-FF7	III-C-95-FF7	III-D-95-FF7
viii)	III-AB-100-FF8	III-C-100-FF8	III-D-100-FF8	III-AB-95-FF8	III-C-95-FF8	III-D-95-FF8
ix)	III-AB-100-FF9	III-C-100-FF9	III-D-100-FF9	III-AB-95-FF9	III-C-95-FF9	III-D-95-FF9
x)	III-AB-100-FF10	III-C-100-FF10	III-D-100-FF10	III-AB-95-FF10	III-C-95-FF10	III-D-95-FF10
xi)	III-AB-100-FF11	III-C-100-FF11	III-D-100-FF11	III-AB-95-FF11	III-C-95-FF11	III-D-95-FF11
xii)	III-AB-100-FF12	III-C-100-FF12	III-D-100-FF12	III-AB-95-FF12	III-C-95-FF12	III-D-95-FF12
xiii)	III-AB-100-FF13	III-C-100-FF13	III-D-100-FF13	III-AB-95-FF13	III-C-95-FF13	III-D-95-FF13
xiv)	III-AB-100-FF14	III-C-100-FF14	III-D-100-FF14	III-AB-95-FF14	III-C-95-FF14	III-D-95-FF14
xv)	III-AB-100-FF15	III-C-100-FF15	III-D-100-FF15	III-AB-95-FF15	III-C-95-FF15	III-D-95-FF15
xvi)	III-AB-100-FF16	III-C-100-FF16	III-D-100-FF16	III-AB-95-FF16	III-C-95-FF16	III-D-95-FF16
xvii)	III-AB-100-FF17	III-C-100-FF17	III-D-100-FF17	III-AB-95-FF17	III-C-95-FF17	III-D-95-FF17

SI No.	Full Ground Motion with 100 percent Energy			Truncated Ground Motion with 95 percent Energy		
	Site Classes A and B	Site Class C	Site Class D	Site Classes A and B	Site Class C	Site Class D
(1)	(2)	(3)	(4)	(5)	(6)	(7)
xviii)	III-AB-100-FF18	III-C-100-FF18	III-D-100-FF18	III-AB-95-FF18	III-C-95-FF18	III-D-95-FF18
xix)	III-AB-100-FF19	III-C-100-FF19	III-D-100-FF19	III-AB-95-FF19	III-C-95-FF19	III-D-95-FF19
xx)	III-AB-100-FF20	III-C-100-FF20	III-D-100-FF20	III-AB-95-FF20	III-C-95-FF20	III-D-95-FF20
xxi)	III-AB-100-FF21	III-C-100-FF21	III-D-100-FF21	III-AB-95-FF21	III-C-95-FF21	III-D-95-FF21
xxii)	III-AB-100-FF22	III-C-100-FF22	III-D-100-FF22	III-AB-95-FF22	III-C-95-FF22	III-D-95-FF22
xxiii)	III-AB-100-FF23	III-C-100-FF23	III-D-100-FF23	III-AB-95-FF23	III-C-95-FF23	III-D-95-FF23
xxiv)	III-AB-100-FF24	III-C-100-FF24	III-D-100-FF24	III-AB-95-FF24	III-C-95-FF24	III-D-95-FF24
xxv)	III-AB-100-FF25	III-C-100-FF25	III-D-100-FF25	III-AB-95-FF25	III-C-95-FF25	III-D-95-FF25
xxvi)	III-AB-100-FF26	III-C-100-FF26	III-D-100-FF26	III-AB-95-FF26	III-C-95-FF26	III-D-95-FF26
xxvii)	III-AB-100-FF27	III-C-100-FF27	III-D-100-FF27	III-AB-95-FF27	III-C-95-FF27	III-D-95-FF27
xxviii)	III-AB-100-FF28	III-C-100-FF28	III-D-100-FF28	III-AB-95-FF28	III-C-95-FF28	III-D-95-FF28
xxix)	III-AB-100-FF29	III-C-100-FF29	III-D-100-FF29	III-AB-95-FF29	III-C-95-FF29	III-D-95-FF29
xxx)	III-AB-100-FF30	III-C-100-FF30	III-D-100-FF30	III-AB-95-FF30	III-C-95-FF30	III-D-95-FF30

Table 25 Details of 30 Far-Fault Ground Motions Compatible with Design PSA Spectrum in Earthquake Zone II

[Table 19, Sl No. (v)]

Sl No.	Full Ground Motion with 100 percent Energy			Truncated Ground Motion with 95 percent Energy		
	Site Classes A and B	Site Class C	Site Class D	Site Classes A and B	Site Class C	Site Class D
(1)	(2)	(3)	(4)	(5)	(6)	(7)
i)	II-AB-100-FF1	II-C-100-FF1	II-D-100-FF1	II-AB-95-FF1	II-C-95-FF1	II-D-95-FF1
ii)	II-AB-100-FF2	II-C-100-FF2	II-D-100-FF2	II-AB-95-FF2	II-C-95-FF2	II-D-95-FF2
iii)	II-AB-100-FF3	II-C-100-FF3	II-D-100-FF3	II-AB-95-FF3	II-C-95-FF3	II-D-95-FF3
iv)	II-AB-100-FF4	II-C-100-FF4	II-D-100-FF4	II-AB-95-FF4	II-C-95-FF4	II-D-95-FF4
v)	II-AB-100-FF5	II-C-100-FF5	II-D-100-FF5	II-AB-95-FF5	II-C-95-FF5	II-D-95-FF5
vi)	II-AB-100-FF6	II-C-100-FF6	II-D-100-FF6	II-AB-95-FF6	II-C-95-FF6	II-D-95-FF6
vii)	II-AB-100-FF7	II-C-100-FF7	II-D-100-FF7	II-AB-95-FF7	II-C-95-FF7	II-D-95-FF7
viii)	II-AB-100-FF8	II-C-100-FF8	II-D-100-FF8	II-AB-95-FF8	II-C-95-FF8	II-D-95-FF8
ix)	II-AB-100-FF9	II-C-100-FF9	II-D-100-FF9	II-AB-95-FF9	II-C-95-FF9	II-D-95-FF9
x)	II-AB-100-FF10	II-C-100-FF10	II-D-100-FF10	II-AB-95-FF10	II-C-95-FF10	II-D-95-FF10
xi)	II-AB-100-FF11	II-C-100-FF11	II-D-100-FF11	II-AB-95-FF11	II-C-95-FF11	II-D-95-FF11
xii)	II-AB-100-FF12	II-C-100-FF12	II-D-100-FF12	II-AB-95-FF12	II-C-95-FF12	II-D-95-FF12
xiii)	II-AB-100-FF13	II-C-100-FF13	II-D-100-FF13	II-AB-95-FF13	II-C-95-FF13	II-D-95-FF13
xiv)	II-AB-100-FF14	II-C-100-FF14	II-D-100-FF14	II-AB-95-FF14	II-C-95-FF14	II-D-95-FF14
xv)	II-AB-100-FF15	II-C-100-FF15	II-D-100-FF15	II-AB-95-FF15	II-C-95-FF15	II-D-95-FF15

Sl No.	Full Ground Motion with 100 percent Energy			Truncated Ground Motion with 95 percent Energy		
	Site Classes A and B	Site Class C	Site Class D	Site Classes A and B	Site Class C	Site Class D
(1)	(2)	(3)	(4)	(5)	(6)	(7)
xvi)	II-AB-100-FF16	II-C-100-FF16	II-D-100-FF16	II-AB-95-FF16	II-C-95-FF16	II-D-95-FF16
xvii)	II-AB-100-FF17	II-C-100-FF17	II-D-100-FF17	II-AB-95-FF17	II-C-95-FF17	II-D-95-FF17
xviii)	II-AB-100-FF18	II-C-100-FF18	II-D-100-FF18	II-AB-95-FF18	II-C-95-FF18	II-D-95-FF18
xix)	II-AB-100-FF19	II-C-100-FF19	II-D-100-FF19	II-AB-95-FF19	II-C-95-FF19	II-D-95-FF19
xx)	II-AB-100-FF20	II-C-100-FF20	II-D-100-FF20	II-AB-95-FF20	II-C-95-FF20	II-D-95-FF20
xxi)	II-AB-100-FF21	II-C-100-FF21	II-D-100-FF21	II-AB-95-FF21	II-C-95-FF21	II-D-95-FF21
xxii)	II-AB-100-FF22	II-C-100-FF22	II-D-100-FF22	II-AB-95-FF22	II-C-95-FF22	II-D-95-FF22
xxiii)	II-AB-100-FF23	II-C-100-FF23	II-D-100-FF23	II-AB-95-FF23	II-C-95-FF23	II-D-95-FF23
xxiv)	II-AB-100-FF24	II-C-100-FF24	II-D-100-FF24	II-AB-95-FF24	II-C-95-FF24	II-D-95-FF24
xxv)	II-AB-100-FF25	II-C-100-FF25	II-D-100-FF25	II-AB-95-FF25	II-C-95-FF25	II-D-95-FF25
xxvi)	II-AB-100-FF26	II-C-100-FF26	II-D-100-FF26	II-AB-95-FF26	II-C-95-FF26	II-D-95-FF26
xxvii)	II-AB-100-FF27	II-C-100-FF27	II-D-100-FF27	II-AB-95-FF27	II-C-95-FF27	II-D-95-FF27
xxviii)	II-AB-100-FF28	II-C-100-FF28	II-D-100-FF28	II-AB-95-FF28	II-C-95-FF28	II-D-95-FF28
xxix)	II-AB-100-FF29	II-C-100-FF29	II-D-100-FF29	II-AB-95-FF29	II-C-95-FF29	II-D-95-FF29
xxx)	II-AB-100-FF30	II-C-100-FF30	II-D-100-FF30	II-AB-95-FF30	II-C-95-FF30	II-D-95-FF30

Table 26 Details of 30 Near-Fault Ground Motions Compatible with Design PSA Spectrum in Earthquake Zone VI

[Table 19, Sl No. (i)]

Sl No.	Full Ground Motion with 100 percent Energy			Truncated Ground Motion with 95 percent Energy		
	Site Classes A and B	Site Class C	Site Class D	Site Classes A and B	Site Class C	Site Class D
(1)	(2)	(3)	(4)	(5)	(6)	(7)
i)	VI-AB-100-NF1	VI-C-100-NF1	VI-D-100-NF1	VI-AB-95-NF1	VI-C-95-NF1	VI-D-95-NF1
ii)	VI-AB-100-NF2	VI-C-100-NF2	VI-D-100-NF2	VI-AB-95-NF2	VI-C-95-NF2	VI-D-95-NF2
iii)	VI-AB-100-NF3	VI-C-100-NF3	VI-D-100-NF3	VI-AB-95-NF3	VI-C-95-NF3	VI-D-95-NF3
iv)	VI-AB-100-NF4	VI-C-100-NF4	VI-D-100-NF4	VI-AB-95-NF4	VI-C-95-NF4	VI-D-95-NF4
v)	VI-AB-100-NF5	VI-C-100-NF5	VI-D-100-NF5	VI-AB-95-NF5	VI-C-95-NF5	VI-D-95-NF5
vi)	VI-AB-100-NF6	VI-C-100-NF6	VI-D-100-NF6	VI-AB-95-NF6	VI-C-95-NF6	VI-D-95-NF6
vii)	VI-AB-100-NF7	VI-C-100-NF7	VI-D-100-NF7	VI-AB-95-NF7	VI-C-95-NF7	VI-D-95-NF7
viii)	VI-AB-100-NF8	VI-C-100-NF8	VI-D-100-NF8	VI-AB-95-NF8	VI-C-95-NF8	VI-D-95-NF8
ix)	VI-AB-100-NF9	VI-C-100-NF9	VI-D-100-NF9	VI-AB-95-NF9	VI-C-95-NF9	VI-D-95-NF9
x)	VI-AB-100-NF10	VI-C-100-NF10	VI-D-100-NF10	VI-AB-95-NF10	VI-C-95-NF10	VI-D-95-NF10
xi)	VI-AB-100-NF11	VI-C-100-NF11	VI-D-100-NF11	VI-AB-95-NF11	VI-C-95-NF11	VI-D-95-NF11
xii)	VI-AB-100-NF12	VI-C-100-NF12	VI-D-100-NF12	VI-AB-95-NF12	VI-C-95-NF12	VI-D-95-NF12
xiii)	VI-AB-100-NF13	VI-C-100-NF13	VI-D-100-NF13	VI-AB-95-NF13	VI-C-95-NF13	VI-D-95-NF13
xiv)	VI-AB-100-NF14	VI-C-100-NF14	VI-D-100-NF14	VI-AB-95-NF14	VI-C-95-NF14	VI-D-95-NF14
xv)	VI-AB-100-NF15	VI-C-100-NF15	VI-D-100-NF15	VI-AB-95-NF15	VI-C-95-NF15	VI-D-95-NF15
xvi)	VI-AB-100-NF16	VI-C-100-NF16	VI-D-100-NF16	VI-AB-95-NF16	VI-C-95-NF16	VI-D-95-NF16

SI No.	Full Ground Motion with 100 percent Energy			Truncated Ground Motion with 95 percent Energy		
	Site Classes A and B	Site Class C	Site Class D	Site Classes A and B	Site Class C	Site Class D
(1)	(2)	(3)	(4)	(5)	(6)	(7)
xvii)	VI-AB-100-NF17	VI-C-100-NF17	VI-D-100-NF17	VI-AB-95-NF17	VI-C-95-NF17	VI-D-95-NF17
xviii)	VI-AB-100-NF18	VI-C-100-NF18	VI-D-100-NF18	VI-AB-95-NF18	VI-C-95-NF18	VI-D-95-NF18
xix)	VI-AB-100-NF19	VI-C-100-NF19	VI-D-100-NF19	VI-AB-95-NF19	VI-C-95-NF19	VI-D-95-NF19
xx)	VI-AB-100-NF20	VI-C-100-NF20	VI-D-100-NF20	VI-AB-95-NF20	VI-C-95-NF20	VI-D-95-NF20
xxi)	VI-AB-100-NF21	VI-C-100-NF21	VI-D-100-NF21	VI-AB-95-NF21	VI-C-95-NF21	VI-D-95-NF21
xxii)	VI-AB-100-NF22	VI-C-100-NF22	VI-D-100-NF22	VI-AB-95-NF22	VI-C-95-NF22	VI-D-95-NF22
xxiii)	VI-AB-100-NF23	VI-C-100-NF23	VI-D-100-NF23	VI-AB-95-NF23	VI-C-95-NF23	VI-D-95-NF23
xxiv)	VI-AB-100-NF24	VI-C-100-NF24	VI-D-100-NF24	VI-AB-95-NF24	VI-C-95-NF24	VI-D-95-NF24
xxv)	VI-AB-100-NF25	VI-C-100-NF25	VI-D-100-NF25	VI-AB-95-NF25	VI-C-95-NF25	VI-D-95-NF25
xxvi)	VI-AB-100-NF26	VI-C-100-NF26	VI-D-100-NF26	VI-AB-95-NF26	VI-C-95-NF26	VI-D-95-NF26
xxvii)	VI-AB-100-NF27	VI-C-100-NF27	VI-D-100-NF27	VI-AB-95-NF27	VI-C-95-NF27	VI-D-95-NF27
xxviii)	VI-AB-100-NF28	VI-C-100-NF28	VI-D-100-NF28	VI-AB-95-NF28	VI-C-95-NF28	VI-D-95-NF28
xxix)	VI-AB-100-NF29	VI-C-100-NF29	VI-D-100-NF29	VI-AB-95-NF29	VI-C-95-NF29	VI-D-95-NF29
xxx)	VI-AB-100-NF30	VI-C-100-NF30	VI-D-100-NF30	VI-AB-95-NF30	VI-C-95-NF30	VI-D-95-NF30

Table 27 Details of 30 Near-Fault Ground Motions Compatible with Design PSA Spectrum in Earthquake Zone V

[Table 19, SI No. (ii)]

SI No.	Full Ground Motion with 100 percent Energy			Truncated Ground Motion with 95 percent Energy		
	Site Classes A and B	Site Class C	Site Class D	Site Classes A and B	Site Class C	Site Class D
(1)	(2)	(3)	(4)	(5)	(6)	(7)
i)	V-AB-100-NF1	V-C-100-NF1	V-D-100-NF1	V-AB-95-NF1	V-C-95-NF1	V-D-95-NF1
ii)	V-AB-100-NF2	V-C-100-NF2	V-D-100-NF2	V-AB-95-NF2	V-C-95-NF2	V-D-95-NF2
iii)	V-AB-100-NF3	V-C-100-NF3	V-D-100-NF3	V-AB-95-NF3	V-C-95-NF3	V-D-95-NF3
iv)	V-AB-100-NF4	V-C-100-NF4	V-D-100-NF4	V-AB-95-NF4	V-C-95-NF4	V-D-95-NF4
v)	V-AB-100-NF5	V-C-100-NF5	V-D-100-NF5	V-AB-95-NF5	V-C-95-NF5	V-D-95-NF5
vi)	V-AB-100-NF6	V-C-100-NF6	V-D-100-NF6	V-AB-95-NF6	V-C-95-NF6	V-D-95-NF6
vii)	V-AB-100-NF7	V-C-100-NF7	V-D-100-NF7	V-AB-95-NF7	V-C-95-NF7	V-D-95-NF7
viii)	V-AB-100-NF8	V-C-100-NF8	V-D-100-NF8	V-AB-95-NF8	V-C-95-NF8	V-D-95-NF8
ix)	V-AB-100-NF9	V-C-100-NF9	V-D-100-NF9	V-AB-95-NF9	V-C-95-NF9	V-D-95-NF9
x)	V-AB-100-NF10	V-C-100-NF10	V-D-100-NF10	V-AB-95-NF10	V-C-95-NF10	V-D-95-NF10
xi)	V-AB-100-NF11	V-C-100-NF11	V-D-100-NF11	V-AB-95-NF11	V-C-95-NF11	V-D-95-NF11
xii)	V-AB-100-NF12	V-C-100-NF12	V-D-100-NF12	V-AB-95-NF12	V-C-95-NF12	V-D-95-NF12
xiii)	V-AB-100-NF13	V-C-100-NF13	V-D-100-NF13	V-AB-95-NF13	V-C-95-NF13	V-D-95-NF13
xiv)	V-AB-100-NF14	V-C-100-NF14	V-D-100-NF14	V-AB-95-NF14	V-C-95-NF14	V-D-95-NF14
xv)	V-AB-100-NF15	V-C-100-NF15	V-D-100-NF15	V-AB-95-NF15	V-C-95-NF15	V-D-95-NF15

SI No.	Full Ground Motion with 100 percent Energy			Truncated Ground Motion with 95 percent Energy		
	Site Classes A and B	Site Class C	Site Class D	Site Classes A and B	Site Class C	Site Class D
(1)	(2)	(3)	(4)	(5)	(6)	(7)
xvi)	V-AB-100-NF16	V-C-100-NF16	V-D-100-NF16	V-AB-95-NF16	V-C-95-NF16	V-D-95-NF16
xvii)	V-AB-100-NF17	V-C-100-NF17	V-D-100-NF17	V-AB-95-NF17	V-C-95-NF17	V-D-95-NF17
xxviii)	V-AB-100-NF18	V-C-100-NF18	V-D-100-NF18	V-AB-95-NF18	V-C-95-NF18	V-D-95-NF18
xix)	V-AB-100-NF19	V-C-100-NF19	V-D-100-NF19	V-AB-95-NF19	V-C-95-NF19	V-D-95-NF19
xx)	V-AB-100-NF20	V-C-100-NF20	V-D-100-NF20	V-AB-95-NF20	V-C-95-NF20	V-D-95-NF20
xxi)	V-AB-100-NF21	V-C-100-NF21	V-D-100-NF21	V-AB-95-NF21	V-C-95-NF21	V-D-95-NF21
xxii)	V-AB-100-NF22	V-C-100-NF22	V-D-100-NF22	V-AB-95-NF22	V-C-95-NF22	V-D-95-NF22
xxiii)	V-AB-100-NF23	V-C-100-NF23	V-D-100-NF23	V-AB-95-NF23	V-C-95-NF23	V-D-95-NF23
xxiv)	V-AB-100-NF24	V-C-100-NF24	V-D-100-NF24	V-AB-95-NF24	V-C-95-NF24	V-D-95-NF24
xxv)	V-AB-100-NF25	V-C-100-NF25	V-D-100-NF25	V-AB-95-NF25	V-C-95-NF25	V-D-95-NF25
xxvi)	V-AB-100-NF26	V-C-100-NF26	V-D-100-NF26	V-AB-95-NF26	V-C-95-NF26	V-D-95-NF26
xxvii)	V-AB-100-NF27	V-C-100-NF27	V-D-100-NF27	V-AB-95-NF27	V-C-95-NF27	V-D-95-NF27
xxviii)	V-AB-100-NF28	V-C-100-NF28	V-D-100-NF28	V-AB-95-NF28	V-C-95-NF28	V-D-95-NF28
xxix)	V-AB-100-NF29	V-C-100-NF29	V-D-100-NF29	V-AB-95-NF29	V-C-95-NF29	V-D-95-NF29
xxx)	V-AB-100-NF30	V-C-100-NF30	V-D-100-NF30	V-AB-95-NF30	V-C-95-NF30	V-D-95-NF30

ANNEX F

(Foreword)

COMMITTEE COMPOSITION

Earthquake Engineering Sectional Committee, CED 39

<i>Organization</i>	<i>Representative(s)</i>
Indian Institute of Technology Madras, Chennai	PROF C. V. R. MURTY (Chairperson)
Atomic Energy Regulatory Board, Mumbai	DR A. D. ROSHAN SHRI AJAY S. PISHARADY (<i>Alternate I</i>)
B & S Engineering Consultants, Noida	SHRI ALOK BHOWMICK SHRI SANJAY KUMAR JAIN (<i>Alternate</i>)
Bharat Heavy Electrical Limited, New Delhi	SHRI S. K. MAHATO SHRI AMIT KUMAR THAKUR (<i>Alternate I</i>) SHRI RAVI KUMAR PONNA (<i>Alternate II</i>)
Central Public Works Department, New Delhi	SHRI DINESH KUMAR UJJAINIA
Central Water Commission, New Delhi	DIRECTOR, CMDD (E&NE) DIRECTOR, EMBANKMENT (NW&S) (<i>Alternate</i>)
Creative Design Consultants Pvt Ltd, Ghaziabad	SHRI AMAN DEEP SHRI BARJINDER (<i>Alternate</i>)
CSIR - Central Building Research Institute, Roorkee	PROF PRADEEP KUMAR RAMANCHARLA DR AJAY P. CHOURASIA (<i>Alternate</i>)
CSIR - National Geophysical Research Institute, Hyderabad	DR PRANTIK MANDAL DR SANDEEP KUMAR GUPTA (<i>Alternate</i>)
CSIR - Structural Engineering Research Centre, Chennai	SHRIMATI R. SREEKALA DR K. SATISH KUMAR (<i>Alternate</i>)
DDF Consultants Pvt Ltd, New Delhi	DR PRATIMA R. BOSE SHRI SADANAND OJHA (<i>Alternate</i>)
Engineers India Limited, New Delhi	DR G. G. SRINIVAS ACHARY DR SUDIP PAUL (<i>Alternate I</i>) MS DIVYA KHULLAR (<i>Alternate II</i>)
Geological Survey of India, Kolkata	SHRI L. H. MOIRANGCHA SHRI SNEHASIS BHATTACHARYA (<i>Alternate</i>)
Indian Association of Structural Engineers, New Delhi	SHRI MANOJ MITTAL SHRI RAJIV AHUJA (<i>Alternate</i>)
Indian Concrete Institute, Chennai	PROF K. P. JAYA PROF DEBASHISH BANDOPADHYAY (<i>Alternate</i>)
Indian Institute of Technology Bhubaneswar, Bhubaneswar	DR SURESH RANJAN DASH
Indian Institute of Technology Bombay, Mumbai	PROF RAVI SINHA PROF ALOK GOYAL (<i>Alternate</i>)

<i>Organization</i>	<i>Representative(s)</i>
Indian Institute of Technology Delhi, New Delhi	PROF DIPTI RANJAN SAHOO PROF VASANT MATSAGAR (<i>Alternate</i>)
Indian Institute of Technology Gandhinagar, Gandhinagar	PROF AMIT PRASHANT DR MANISH KUMAR (<i>Alternate</i>)
Indian Institute of Technology Kanpur, Kanpur	PROF DURGESH C. RAI
Indian Institute of Technology Madras, Chennai	PROF A. MEHER PRASAD PROF RUPEN GOSWAMI (<i>Alternate</i>)
Indian Institute of Technology Roorkee, Roorkee	PROF YOGENDRA SINGH PROF MANISH SHRIKHANDE (<i>Alternate I</i>) PROF B. K. MAHESHWARI (<i>Alternate II</i>) DR P. C. ASHWIN KUMAR (<i>Alternate III</i>)
Indian Society of Earthquake Technology, Roorkee	PRESIDENT VICE PRESIDENT (<i>Alternate</i>)
International Institute of Information Technology, Hyderabad	DR SUNITHA PALISSERY DR PRAVIN KUMAR VENKAT RAO (<i>Alternate I</i>) DR SHUBHAM SINGHAL (<i>Alternate II</i>)
Malviya National Institute of Technology Jaipur, Jaipur	PROF S. D. BHARTI PROF M. K. SHRIMALI (<i>Alternate</i>)
National Centre for Seismology, Ministry of Earth Sciences, New Delhi	DR O. P. MISHRA DR H. S. MANDAL (<i>Alternate</i>)
National Disaster Management Authority, New Delhi	SHRI BISWARUP DAS SHRI ABHISHEK SHARMA (<i>Alternate I</i>) SHRIMATI RANU CHAUHAN (<i>Alternate II</i>)
NTPC Limited, New Delhi	DR PRAVEEN KHANDELWAL SHRI SAURABH GUPTA (<i>Alternate</i>)
Nuclear Power Corporation India Limited, Mumbai	DR RAJIV RANJAN SHRI GIRISH PATIL (<i>Alternate</i>)
Research Design and Standards Organization, Lucknow	SHRI MOHIT VERMA SHRI MANISH KUMAR (<i>Alternate I</i>) SHRI SANDEEP SINGH (<i>Alternate II</i>)
R. S. Mandrekar and Associates, Mumbai	DR JASWANT N. ARLEKAR SHRI PANKAJ PATIL (<i>Alternate I</i>) SHRIMATI SHREYA MANDREKAR (<i>Alternate II</i>)
Steel Authority of India Limited R&D Centre, Ranchi	SHRI K. K. SINGH
Tandon Consultants Private Limited, New Delhi	PROF MAHESH TANDON DR VINAY K. GUPTA (<i>Alternate</i>)
Tata Consulting Engineers, Mumbai	SHRI ARJUN C. R.
Vakil Mehta Sheth Consulting Engineers, Mumbai	MS ALPA R. SHETH SHRI R. D. CHAUDHARI (<i>Alternate</i>)

<i>Organization</i>	<i>Representative(s)</i>
National Institute of Technology Goa, South Goa	PROF O. R. JAISWAL DR HARIKUMAR M. (<i>Alternate</i>)
In Personal Capacity (<i>200 N.S.C. Bose Road South Enclave, Flat 301, Kolkata</i>)	DR INDRAJIT CHOUDHARY
In Personal Capacity (<i>Row House 4, Sun City Housing Society, Vadgaon Budruk, Pune</i>)	DR I. D. GUPTA
In Personal Capacity (<i>36 Old Sneh Nagar, Wardha Road, Nagpur</i>)	SHRI L. K. JAIN
In Personal Capacity (<i>H-102, VVIP Addresses, Rajnagar Extn, Ghaziabad</i>)	DR A. K. MITTAL
In Personal Capacity (<i>174/2 F Solanipuram, Roorkee</i>)	PROF S. K. THAKKAR
BIS Directorate General	SHRI DWAIPAYAN BHADRA, SCIENTIST 'E'/DIRECTOR AND HEAD (CIVIL ENGINEERING) [REPRESENTING DIRECTOR GENERAL (<i>Ex-officio</i>)]

Member Secretaries
SHRI ARUN KUMAR S.
SCIENTIST 'E'/DIRECTOR

AND

SHRI JITENDRA KUMAR CHAUDHARY
SCIENTIST 'C'/DEPUTY DIRECTOR
(CIVIL ENGINEERING), BIS

Composition of the Maps Subcommittee, CED 39:4

<i>Organization</i>	<i>Representative(s)</i>
In Personal Capacity (<i>Row House 4, Sun City Housing Society, Vadgaon Budruk, Pune</i>)	DR I. D. GUPTA (<i>Convener</i>)
Indian Institute of Technology Madras, Chennai	PROF C. V. R. MURTY (<i>Convener</i>)
Atomic Energy Regulatory Board, Mumbai	DR L. R. BISHNOI DR A.D. ROSHAN (<i>Alternate</i>)
Bhabha Atomic Research Centre, Environmental Monitoring & Assessment Division, Mumbai	SHRI K. SRINIVAS DR PHANIKANTH (<i>Alternate</i>)
CSIR - Centre for Mathematical Modelling and Computer Simulation, Bengaluru	DR IMTIYAZ A. PARVEZ
CSIR - National Geophysical Research Institute, Hyderabad	DR R. K. CHADHA DR D. SRINAGESH (<i>Alternate</i>)
Department of Science & Technology, Survey of India, Lucknow	BRIG G. S. CHANDELA SHRI MOHMAD IQBAL MANIK (<i>Alternate</i>)
Geological Survey of India, New Delhi	SHRI K. C. JOSHI SHRI M. CHANDRADAS (<i>Alternate</i>)

<i>Organization</i>	<i>Representative(s)</i>
Indian Institute of Technology Bombay, Mumbai	PROF RAVI SINHA PROF ALOK GOYAL (<i>Alternate</i>)
Indian Institute of Technology Kanpur, Kanpur	PROF DURGESH C. RAI
Indian Institute of Technology Madras, Chennai	PROF S.T.G. RAGHUKANTH PROF RUPEN GOSWAMI (<i>Alternate</i>)
Indian Institute of Technology Roorkee, Roorkee	PROF M. L. SHARMA DR ASHWANI KUMAR (<i>Alternate</i>)
Institute of Seismological Research, Gandhinagar	DIRECTOR GENERAL
Jain University, Jakkasandra, Bengaluru	PROF R. N. IYENGAR
National Centre for Seismology, Ministry of Earth Sciences, New Delhi	DR O. P. MISHRA DR H. S. MANDAL (<i>Alternate</i>)
National Disaster Management Authority, New Delhi	SHRI BISWARUP DAS SHRI MOHAMMAD JAVED IQBAL (<i>Alternate</i>)
Oil and Natural Gas Corporation Limited, New Delhi	DEPUTY GENERAL MANAGER SUPERINTENDING GEOPHYSICIST (<i>Alternate</i>)
Vakil Mehta Sheth Consulting Engineers, Mumbai	MS ALPA R. SHETH
Wadia Institute of Himalayan Geology, Dehradun	DR VIKRAM GUPTA

Composition of the Working Group

<i>Organization</i>	<i>Representative(s)</i>
Indian Institute of Technology Madras, Chennai	PROF C. V. R. MURTY (<i>Convener</i>) PROF RUPEN GOSWAMI
Indian Institute of Technology Bombay, Mumbai	PROF RAVI SINHA
NTPC Limited, New Delhi	DR PRAVEEN KHANDELWAL
Vakil-Mehta-Sheth Consulting Engineers, Mumbai	MS ALPA R. SHETH



दिल्ली मेट्रो रेल कॉर्पोरेशन लिमिटेड
DELHI METRO RAIL CORPORATION LTD.

List of Empanelled Manufacturers / Suppliers of Major Architecture Items (as on 14.11.2025)

Note: In case the manufacturer / supplier does not have required valid documents / certificates at the time of usage at site, then the product shall not be allowed for usage at site.

Category No.	Category	Material / Item / Product	Manufacturer's / Supplier's Name	Valid Till
A1	Flooring	Vitrified Tiles (Plain, Designer and Tactile)	1. H&R Johnson	Validity dates will be updated soon
			2. Kajaria	
			3. Oasis (Marbomax Group)	
			4. Orient Bell Ceramics	
			5. Pavit Ceramics	
			6. Pelican Ceramics	
			7. Qutone Tiles	
			8. RAK Ceramics	
			9. Restile Ceramics	
			10. Royale Touch and Silk Touch Vitrified	
			11. Simpolo	
			12. Varmora Granito	
13. Vitero				
14. Sunshine Tiles Co. Pvt. Ltd. (Sunhearrt Ceramik)				
15. Karara Ceramics Pvt. Ltd.				
16. Hindware				
17. Somany Ceramics Pvt. Ltd.				
18. Ambani Vitrified Pvt. Ltd.	26.10.2030			
19. Mozart Vitrified Pvt. Ltd.	26.10.2030			
20. Nitco Tiles Ltd.	26.10.2030			
A1	Flooring	Ceramic / Porcelain Tiles	1. H&R Johnson	Validity dates will be updated soon
			2. Kajaria	
			3. Oasis (Marbomax Group)	
			4. Orient Bell Ceramics	
			5. Qutone Tiles	
			6. Simpolo	
			7. Varmora Granito	
			8. Somany Ceramics Pvt. Ltd.	
			9. Hindware	
			10. Karara Ceramics Pvt. Ltd.	
			11. Sunshine Tiles Co. Pvt. Ltd. (Sunhearrt Ceramik)	
A1	Flooring	Raised Floor	1. Hewetson / Kingspan Access Floors	Validity dates will be updated soon
			2. United Access Floors / United Insulation	
			3. AET Flexiblespace India Pvt. Ltd. (FLEXIFLOOR)	26.10.2030
			4. Universal Building Products Pvt. Ltd. (UNIFLOOR)	26.10.2030
A1	Flooring	PU / Epoxy Coated Flooring	1. Cipy Polyurethanes	Validity dates will be updated soon
			2. Flowcrete	
			3. Pidilite	
			4. Shalimar Paints	
			5. Sika	

14/11/2025

ओ. एस. सैनी
महाप्रबंधक / योजना
दिल्ली मेट्रो रेल कॉर्पोरेशन लिमिटेड
मेट्रो भवन, फायर फ्लाइंग लेन,
नारायण रोड, नई दिल्ली-110001



दिल्ली मेट्रो रेल कॉर्पोरेशन लिमिटेड
DELHI METRO RAIL CORPORATION LTD.

List of Empanelled Manufacturers / Suppliers of Major Architecture Items (as on 14.11.2025)

Category No.	Category	Material / Item / Product	Manufacturer's / Supplier's Name	Valid Till
A1	Flooring	PU / Epoxy Coated Flooring	6. Hygie Profile (India) Pvt. Ltd. 7. Berger Paints India Ltd. 8. STP Ltd. 9. Ulfcar Chemicals Pvt. Ltd. (DenCoat) 10. RachTR Chemicals Pvt. Ltd. 11. JSW Paints Ltd. 12. Growel (Grauer & Weil)	Validity dates will be updated soon 26.10.2030 26.10.2030 26.10.2030 26.10.2030
		Concrete Pavers, Kerbs & Chequered Tiles, Paving Tiles, Grass Paver, Plantable Blocks, Hollow Blocks, Retaining Blocks, Slope Stone	1. Chelsea Concrete 2. Dalal Tiles 3. Pave Espania 4. Sarita Pre Fab 5. Perfect Tiles 6. JRC Brickworks Pvt. Ltd. 7. KJS Concrete 8. Parmeshwari Enterprises	Validity dates will be updated soon 26.10.2030
		Ceramic or Glass Mosaic Tiles / Handmade Tile Mosaic Tiles	1. Bisazza 2. GND Tiles 3. Italica Mosaic 4. Kenzai Ceramic 5. Mridul Enterprises 6. Mosaico People Corporation 7. Raja Tiles 8. Ayush Inter Décor	Validity dates will be updated soon
A2	Finishing	Pre-mix Cement Plaster	1. Birla- Aerocon 2. Ultratech Cement Ltd. 3. Ambuja Cements 4. ACC 5. Trimurti	Validity dates will be updated soon
		Emulsion Paints	1. Acro Paints 2. AkzoNobel 3. Asian Paints 4. Berger Paints 5. BSC Paints 6. Godavari Paints 7. Jenson & Nicholson 8. Kamdhenu Paints 9. Nerolac Paints 10. IMAGICO India Pvt. Ltd. (previously OIKOS India Pvt. Ltd.) 11. Shalimar Paints 12. Sherwin-Williams Paints 13. Luxture Surface Coatings Pvt. Ltd. 14. JSW Paints Ltd. 15. Growel (Grauer & Weil)	Validity dates will be updated soon 26.10.2030 26.10.2030

Om
14/11/2025
ओ. एस. सैनी
महाप्रबंधक / योजना
दिल्ली मेट्रो रेल कॉर्पोरेशन लिमिटेड
मेट्रो भवन, फायर ब्रिगेड लेन,
बाराखंबा रोड, नई दिल्ली-110001



दिल्ली मेट्रो रेल कॉर्पोरेशन लिमिटेड
DELHI METRO RAIL CORPORATION LTD.

List of Empanelled Manufacturers / Suppliers of Major Architecture Items (as on 14.11.2025)

Category No.	Category	Material / Item / Product	Manufacturer's / Supplier's Name	Valid Till
A2	Finishing	Synthetic Enamels	1. Acro Paints 2. AkzoNobel 3. Asian Paints 4. Berger Paints 5. Jenson & Nicholson 6. Kamdhenu Paints 7. Nerolac Paints 8. Shalimar Paints 9. Sherwin-Williams Paints 10. Maharani Innovative Paints Pvt. Ltd. 11. JSW Paints Ltd.	Validity dates will be updated soon 26.10.2030
		Polyurethane Paints / Epoxy Paints	1. AkzoNobel 2. Asian Paints 3. Jenson & Nocholson 4. MRF Paints 5. Nerolac Paints 6. Shalimar Paints 7. Sherwin-Williams Paints 8. Berger Paints India Pvt. Ltd. 9. Ameetuff Technical Paints 10. JSW Paints Ltd.	Validity dates will be updated soon 26.10.2030
		Bonding Coat / Primer (for Paint)	1. Pidilite 2. Dr. Fixit 3. Ameetuff Technical Paints 4. Fosroc 5. Ultratech Cement Ltd.	Validity dates will be updated soon 26.10.2030
		Texture Paint	1. AkzoNobel 2. BSC Paints 3. Berger Paints India Pvt. Ltd. 4. Luxture Surface Coating Pvt. Ltd. 5. Ultratech Cement Ltd.	Validity dates will be updated soon 26.10.2030
		Wall Care Putty	1. Birla (Aditya Birla Group) 2. EBIPL: Evershine 3. Gyproc Wall Putty (Saint-Gobain) 4. HIL Ltd. (Aerocon) 5. JK White 6. Shalimar Paints 7. Berger Paints India Pvt. Ltd. 8. Ferrous Crete India Pvt. Ltd. 9. Luxture Surface Coating Pvt. Ltd. 10. Trimurti Wall Care Products Pvt. Ltd. 11. Ultratech Cement Ltd. 12. JSW Paints Ltd.	Validity dates will be updated soon 26.10.2030 26.10.2030 26.10.2030

ओ. एस. सैनी
महाप्रबंधक / योजना
दिल्ली मेट्रो रेल कॉर्पोरेशन लिमिटेड
मेट्रो भवन, फायर ब्रिगेड लेन,
बाराखंबा रोड, नई दिल्ली-110001



दिल्ली मेट्रो रेल कॉर्पोरेशन लिमिटेड
DELHI METRO RAIL CORPORATION LTD.

List of Empanelled Manufacturers / Suppliers of Major Architecture Items (as on 14.11.2025)

Category No.	Category	Material / Item / Product	Manufacturer's / Supplier's Name	Valid Till
A2	Finishing	Glass (Float / Toughened)	1. Asahi Float (AIS) 2. Glaverbel 3. Modiguard 4. Saint-Gobain 5. Art N Glass Group Company 6. Şişecam Glass India Pvt. Ltd.	Validity dates will be updated soon
		Fire Rated Glass	1. FG Glass 2. Pilkington Glass 3. Saint-Gobain 4. Asahi India Glass Ltd. (AIS)	Validity dates will be updated soon
		Structural Glazing Fabricators	1. Permasteelisa India Pvt. Ltd. 2. Alufit India Pvt. Ltd. 3. Shapoorji Pallonji Fab Pvt. Ltd. 4. Innovators Façade Systems Pvt. Ltd.	Validity dates will be updated soon
A3	Cladding	GRC Products (GRC Screen, Panels, etc.)	1. Dalal Tiles 2. Terra firma GRC & Concrete Industries 3. UniStone Products (India) Pvt. Ltd. 4. Ayush Inter Décor 5. Everest Composites Pvt. Ltd. 6. Mahesh Prefab Pvt. Ltd.	Validity dates will be updated soon 26.10.2030
		High Pressure Laminate	1. Fundermax 2. Greenlam 3. Merino 4. Century Plyboards 5. Virgo Laminates Ltd. 6. Samrat Plywood Ltd. 7. Stylam Industries 8. Stonelam Surface LLP	Validity dates will be updated soon
		Acrylic Solid Surface	1. DuPont Corian 2. LX Hausys HIMACS (previously LG Hausys HIMACS)	Validity dates will be updated soon
A4	False Ceiling	Calcium Silicate Board	1. Aerolite 2. Ramco Hilux 3. Promat	Validity dates will be updated soon
		Metal Ceilings	1. Knauf Ceiling Solutions (previously Armstrong World Industries) 2. Dexune 3. durlum 4. Hunter Douglas 5. Canon Fasteners 6. SCJ Mascot LLP (Metacil) 7. JC Industries 8. Royal Kraft (Manraj Ceiling Products) 9. Harsons & Associates (Harsons Green)	Validity dates will be updated soon 26.10.2030 26.10.2030 26.10.2030 26.10.2030

ओ. एस. सैनी
महाप्रबंधक / योजना
दिल्ली मेट्रो रेल कॉर्पोरेशन लिमिटेड
मेट्रो भवन, फायर त्रिगेंड लेन,
बाराखंबा रोड, नई दिल्ली-110001



दिल्ली मेट्रो रेल कॉर्पोरेशन लिमिटेड
DELHI METRO RAIL CORPORATION LTD.

List of Empanelled Manufacturers / Suppliers of Major Architecture Items (as on 14.11.2025)

Category No.	Category	Material / Item / Product	Manufacturer's / Supplier's Name	Valid Till
A5	Adhesive, Fillers, and Sealants	Adhesive for Tiles	1. Araldite	Validity dates will be updated soon
			2. EBIPL: Evershine	
			3. Kerakoll	
			4. Laticrete	
			5. Pidilite	
6. Alstone Industries Pvt. Ltd.				
7. Ultratech Cement Ltd.				
8. Berger Paints India Ltd.				
9. Ferrous Crete India Pvt. Ltd.				
10. Trimurti Wall Care Products Pvt. Ltd.	26.10.2030			
11. RachTR Chemicals Pvt. Ltd.	26.10.2030			
A5	Adhesive, Fillers, and Sealants	Tiles Joint Filler, Tile Grouts	1. Ardex Endura (previously Bal Adhesives and Grouts)	Validity dates will be updated soon
			2. EBIPL: Evershine	
			3. GE Bayer Silicones	
			4. Laticrete	
			5. MC-Bauchemie (India)	
			6. Roff Constructions Chemicals	
			7. Ultratech Cement Ltd.	
			8. Berger Paints India Ltd.	
			9. Kerakoll	
			10. Alstone Industries Pvt. Ltd.	
			11. Ferrous Crete India Pvt. Ltd.	
A5	Adhesive, Fillers, and Sealants	Polysulphide Sealants (for Stone / Vitrified Tiles)	1. 3M	Validity dates will be updated soon
			2. BASF	
			3. CICO	
			4. Fosroc	
			5. McCoy Soudal	
			6. Pidilite	
			7. Sika	
			8. STP Ltd.	
			9. MYK Arment	
			10. Berger Paints India Ltd.	
			11. Ferrous Crete India Pvt. Ltd.	
A5	Adhesive, Fillers, and Sealants	Silicon Sealants	1. 3M	Validity dates will be updated soon
			2. Dow Corning	
			3. GE Bayer Silicones	
			4. McCoy Soudal	
			5. Sika	
			6. Alstone Industries Pvt. Ltd.	
A5	Adhesive, Fillers, and Sealants	Silicon Water Repellent Solution	1. Choksey Chemicals	Validity dates will be updated soon
			2. MC-Bauchemie	
			3. GE Bayer Silicones	
			4. STP Ltd.	
			5. Wacker Metroark	

14/11/2025

ओ. एस. सैनी

महाप्रबंधक / योजना

दिल्ली मेट्रो रेल कॉर्पोरेशन लिमिटेड
मेट्रो भवन, फायर ब्रिगेड लेन,
बाराखम्बा रोड, नई दिल्ली-110001



दिल्ली मेट्रो रेल कॉर्पोरेशन लिमिटेड
DELHI METRO RAIL CORPORATION LTD.

List of Empanelled Manufacturers / Suppliers of Major Architecture Items (as on 14.11.2025)

Category No.	Category	Material / Item / Product	Manufacturer's / Supplier's Name	Valid Till
A6	Joinery Woodwork Products	Plywood	1. Duroply Sarda Plywood 2. Century Ply 3. Greenply Plywood 4. Swastik Plyboard Ltd. (Swati Ply) 5. Merino 6. Archidply 7. Visaka Plywood 8. Vidya Ply & Board 9. Greenpanel Industries Ltd.	Validity dates will be updated soon
			10. Samrat Plywood Ltd.	
		Blockboard	1. Century Ply 2. Duroply Sarda Plywood 3. Greenply Plywood 4. Merino 5. Vidya Ply & Board 6. Greenpanel Industries Ltd.	Validity dates will be updated soon
			Laminates	
		Dry Partition System	1. Aerocon (HIL Ltd.) 2. Metecno 3. V-Board (Visaka Industries Ltd.)	Validity dates will be updated soon
		Toilet Cubicles & Compact Laminated Doors	1. Fundermax 2. Greenlam 3. Merino 4. Stylam Industries	
		Pressed Steel Doors Frame	1. AGEW Steel Manufacturers Pvt. Ltd. 2. Sen-Harvic Windows Pvt. Ltd.	Validity dates will be updated soon
A7	Fire Rated Doors, Fire Rated Glass	PVC / WPC / uPVC Doors & Window / Frame	1. Fenesta 2. Venster 3. Wintrack 4. Rajshri Plastiwood 5. AVSL Industries Ltd. 6. Alstone Industries Pvt. Ltd.	
			1. Bhawani Fire Protection Systems Ltd. 2. Iclean Hollow Metal System Pvt. Ltd. 3. Navair International Ltd. 4. Sehgal & Sehgal 5. Shakti Hormann 6. Signum Fire Protections Pvt. Ltd.	Validity dates will be updated soon

ओ. एस. सैनी
महाप्रबंधक / योजना
दिल्ली मेट्रो रेल कॉर्पोरेशन लिमिटेड
मेट्रो भवन, फायर ब्रिगेड लेन,
बाराखम्बा रोड, नई दिल्ली-110001

14/11/2025



दिल्ली मेट्रो रेल कॉर्पोरेशन लिमिटेड
DELHI METRO RAIL CORPORATION LTD.

List of Empanelled Manufacturers / Suppliers of Major Architecture Items (as on 14.11.2025)

Category No.	Category	Material / Item / Product	Manufacturer's / Supplier's Name	Valid Till
A7	Fire Rated Doors, Fire Rated Glass	Fire Door (Tested as per BIS / BS Standard)	7. SKS Steel Industries 8. Sukriti Doors and Hardware Pvt. Ltd. 9. Trio India 10. JC Fire Door Corporation	26.10.2030 26.10.2030 26.10.2030 26.10.2030
		Fire Door (Tested as per NFPA Standard)	1. GMP Technicals 2. Shakti Hormann	Validity dates will be updated soon
A8	Plumbing	Sanitaryware	1. Cera 2. Hindware 3. Parryware 4. Roca 5. H&R Johnson (India) 6. Euronics Industries Pvt. Ltd.	Validity dates will be updated soon 26.10.2030 26.10.2030
		Sanitary & Bath Fittings	1. Hindware 2. Jaquar 3. Kohler 4. Mayur Ocich 5. H&R Johnson (India) 6. Euronics Industries Pvt. Ltd. 7. Aqua Systems Pvt. Ltd. (JAL- Jupiter Aqualines)	Validity dates will be updated soon 26.10.2030 26.10.2030 26.10.2030
A9	Hardware	Frameless Glass Partition Fixtures	1. Dorma 2. Dorset-Kaba 3. Dline 4. Häfele 5. Hardwyn. 6. Kich	Validity dates will be updated soon
		Spider Fitting / Patch Fittings	1. Dline 2. Kich 3. Ozone	Validity dates will be updated soon
		Anchor Fasteners (for Finishing works)	1. Anchorite Fixing Technology (AFT) 2. Axel India (Trixel) 3. Bosch Fischer 4. Boun Group 5. Hilti India Pvt. Ltd. 6. Hitachi-Mungo 7. Canon Fasteners	Validity dates will be updated soon
		Stone Cladding Clamps	1. Anchorite Fixing Technology (AFT) 2. Axel India (Trixel) 3. Bosch Fischer 4. Boun Group 5. Hilti India Pvt. Ltd. 6. Canon Fasteners	Validity dates will be updated soon

Opinion
14/11/2025

ओ. एस. सैनी
महाप्रबंधक / योजना
दिल्ली मेट्रो रेल कॉर्पोरेशन लिमिटेड
मेट्रो भवन, फायर ब्रिगेड लेन,
बाराखंभा रोड, नई दिल्ली 110001



दिल्ली मेट्रो रेल कॉर्पोरेशन लिमिटेड
DELHI METRO RAIL CORPORATION LTD.

List of Empanelled Manufacturers / Suppliers of Major Architecture Items (as on 14.11.2025)

Category No.	Category	Material / Item / Product	Manufacturer's / Supplier's Name	Valid Till
A9	Hardware	Door Hardware / Architectural Profiles	1. Dorma 2. Dorset-Kaba 3. Diline 4. Häfele 5. Hardwyn 6. Hettich 7. Ozone	Validity dates will be updated soon
A10	Pipes and Fittings	Ductile Iron Pipes	1. Electrosteel Castings Ltd. 2. Jindal	Validity dates will be updated soon
		Cast Iron Pipes, SS Pipes & Fitting (IS 1536)	1. HEPCO 2. NECO 3. Singhal Iron & Foundry (SKFCI)	Validity dates will be updated soon
		GI & MS Pipes (IS 1239 Part-I&II IS 3589)	1. Jindal 2. Prakash Pipes 3. Surya Roshni Ltd. 4. T.T. Swastik 5. Nezone Tubes Ltd. 6. Indus Tubes Ltd.	Validity dates will be updated soon 26.10.2030
		GI Fitting - Malleable (IS 1879 Part I to X)	1. DRP 2. K.S. 3. Unik 4. Zoloto	Validity dates will be updated soon
		uPVC Pipes & Fittings (IS 4985 : 1981)	1. Finolex 2. Jindal Plast India 3. Prakash Pipes 4. Polypack 5. Prince 6. Rex 7. Supreme 8. Surya Roshni Ltd. 9. HIL Ltd. (Birla-Aerocon) 10. Fusion Industries Ltd. (Fusion Pipes) 11. AKG Extrusions Pvt. Ltd. (AKG Group)	Validity dates will be updated soon 26.10.2030 26.10.2030
		CPVC Pipes & Fittings (IS 15778 : 2007)	1. Ajay 2. Ashirvad 3. Astral 4. Finolex 5. Surya Roshni 6. HIL Ltd. (Birla-Aerocon) 7. Fusion Industries Ltd. (Fusion Pipes) 8. AKG Extrusions Pvt. Ltd. (AKG Group)	Validity dates will be updated soon 26.10.2030 26.10.2030

Opai 14/11/2025
ओ. एस. सेनी
महाप्रबंधक / योजना
दिल्ली मेट्रो रेल कॉर्पोरेशन लिमिटेड
मेट्रो भवन, फायर ब्रिगेड लेन,
बाराखंबा रोड, नई दिल्ली-110001



दिल्ली मेट्रो रेल कॉर्पोरेशन लिमिटेड
DELHI METRO RAIL CORPORATION LTD.

List of Empanelled Manufacturers / Suppliers of Major Architecture Items (as on 14.11.2025)

Category No.	Category	Material / Item / Product	Manufacturer's / Supplier's Name	Valid Till
A10	Pipes and Fittings	Stoneware Pipes & Gully Traps (IS 651)	1. Lal Chand Anand & Sons 2. Perfect	Validity dates will be updated soon
		RCC Pipes (IS 458)	1. Daya Concrete 2. Jain Spun 3. Pragati	Validity dates will be updated soon
		Copper Pipes & Fittings	1. Mehta Tubes 2. Mexflow 3. Rajco	Validity dates will be updated soon
		HDPE Pipes & Fittings	1. Duraline 2. Geberit 3. Reliance	Validity dates will be updated soon
		PPR Pipes & Fittings	1. Prince 2. Supreme 3. Uro-Allwin 4. Kanha Plastics Pvt. Ltd. (KPT)	Validity dates will be updated soon
A11	Water-proofing / Repellents Compound	Modified Bituminous Membrane Roof Waterproofing	1. Asian Paints 2. BASF 3. EBIPL: Evershine 4. Flowcrete 5. Fosroc 6. Kemco 7. Sika 8. STP Ltd. 9. MYK Arment 10. Berger Paints India Ltd. 11. Ultratech Cement Ltd.	Validity dates will be updated soon 26.10.2030
A12	Metal and Roofing	Aluminium Section	1. Bharat Aluminium Company United / Vedanta BALCO 2. Bhoruka 3. Hindalco 4. Jindal Aluminium Ltd. 5. Maan Aluminium Ltd. 6. Technorail 7. MM Metacraft Pvt. Ltd.	Validity dates will be updated soon 26.10.2030
		M.S. Hollow Sections Pipes	1. APL Apollo 2. Hi-Tech Pipes 3. Jindal 4. Surya Roshni 5. Nezone Tubes	Validity dates will be updated soon
		M.S. Tubes / Sections	1. APL Apollo 2. ISPAT 3. Jindal	Validity dates will be updated soon

ओ. एस. सेनी
महाप्रबंधक / योजना
दिल्ली मेट्रो रेल कॉर्पोरेशन लिमिटेड
मेट्रो भवन, फायर ब्रिगेड लेन,
बाराखम्बा रोड, नई दिल्ली-110001



दिल्ली मेट्रो रेल कॉर्पोरेशन लिमिटेड
DELHI METRO RAIL CORPORATION LTD.

List of Empanelled Manufacturers / Suppliers of Major Architecture Items (as on 14.11.2025)

Category No.	Category	Material / Item / Product	Manufacturer's / Supplier's Name	Valid Till
A12	Metal and Roofing	M.S. Tubes / Sections	4. Rana Steel 5. Swastik Pipes 6. Tata Structura	Validity dates will be updated soon
		Prefabricated SS Works / SS Works	1. Dline 2. Jindal Stainless (JSL) 3. Kich 4. Ozone 5. Konzept Steel Pvt. Ltd. 6. Technorail 7. Sialkot Shop	Validity dates will be updated soon 26.10.2030
		Metal Roofs System	1. Kalzip 2. Supertech (India) Pvt. Ltd. 3. Tata BlueScope (Metal Coated and Pre-Painted Sheets ZINCALUME COLORBOND)	Validity dates will be updated soon
		Polycarbonate Sheets	1. Danpalon 2. Lexan (SABIC Innovative Plastics from GE)	Validity dates will be updated soon
		Tensile Fabric	1. Ferrari 2. Mehler	Validity dates will be updated soon

Dr. Saini
14/11/2025

ओ. एस. सैनी
महाप्रबंधक / योजना
दिल्ली मेट्रो रेल कॉर्पोरेशन लिमिटेड
मेट्रो भवन, फायर ब्रिगेड लेन,
बाराखम्भा रोड, नई दिल्ली-110001

"Contract D2C-06: "Design and Construction of Twin Tunnel by Shield TBM, Cut & Cover tunnel box, Underground ramp and & by method other than TBM, four underground stations namely, Dayabasti, Sarai Rohilla, Ajmal Khan park, Jhandewalan Mandir and Balance work of works for Nabi Karim Station with Entry/Exits including Retrieval/Launching shafts, Architectural Finishing, Water Supply, Sanitary Installation & Drainage works from chainage (down line) CH: 440.000 mt 614.483 mt. to CH: 7629.531 mt of Inderlok-Indraprastha corridor (Extn. of Line-5) of Delhi MRTS Project of Phase-IV."

Reply to Pre-bid Queries

Bidder-A

Sr. No.	Document Name	Page No.	Clause Number	Original Tender Clause	Bidder's Queries	DMRC's Reply
1.	Addendum-7	1	No-2	Addendum-7, S. No.2 specifies that the structure shall be designed as per IS 1893:2025 (Latest Code)	The specified code (IS 1893:2025) has not yet been published officially by BIS; Since all the Tender design done based on the existing code it will be very difficult for contractor to design with unofficial code. Request to kindly delete this clause.	A copy of the circulation code (IS 1893- Part-1(2025)) appended herewith in Addendum 08. Hence, the seismic design of structures needs to be done in accordance of this code.
2.	Addendum-7	1	No-2	Addendum-7, S. No.2 specifies that the structure shall be designed as per IS 1893:2025 (Latest Code)	Request to specify the category (e.g., Important, Critical, etc.) of the structure as per the latest code.	All structures including tunnel in this tender are on "Critical" Category.
3.	Addendum-7	1	No-2	Addendum-7, S. No.2 specifies that the structure shall be designed as per IS 1893:2025 (Latest Code)	Request to incorporate the necessary modifications in the ODS for ODE (Operating Design Earthquake) and MDE (Maximum Design Earthquake) as per the latest Code.	Refer Reply at Sr. No.1 above.
4.	Addendum-7	1	No-2	Addendum-7, S. No.2 specifies that the structure shall be designed as per IS 1893:2025 (Latest Code)	After receiving the response to the above queries, if the IS 1893:2025 (Which is not officially published) is required to be followed, additional time will be required for	A copy of the circulation code (IS 1893- Part-1(2025)) is appended.

					incorporating it into the tender design and assessing its impact. Since this will require complete redesign, which is a major change, we request that the deadline for submission of bids be extended to at least three weeks from the date of response to these questions.	
--	--	--	--	--	---	--

Bidder-B

Sl. no	Reference volume / Reference section and complete description of clause	Relevant page no. of Bid Documents	Queries	DMRC's Reply
1	IS Code	Part-2 of addendum 7, Sr. No.2	<p>As per addendum No. 7: The reference of Is 1893 (Part-1) 2016 mentioned in ODS (Outline design Specification) and at any other pace of Bid documents should be read as the latest code i.e. IS 1893-Part-1 2025</p> <p>Query: in above addendum it is being mentioned to use the Latest IS code (IS 1893- Part-1 (2025), however the latest IS code is yet to be published and hence we request you to reference to the old IS code as mentioned in ODS.</p>	A copy of the circulation code (IS 1893- Part-1(2025)) appended herewith in Addendum 08. Hence, the seismic design of structures needs to be done in accordance of this code.